

FUTEK MODEL LLW200
ITEM# FSH01595

FORCE WASHER LOAD CELL

(Previously L2720)

Drawing Number: FI1128-B

INCH [mm] | R.O.= Rated Output

WIRING CODE (WC1)

+Excitation	-Excitation	+Signal	-Signal
RED	BLACK	GREEN	WHITE

Shield
FLOATING

+ OUTPUT
(COMPRESSION)

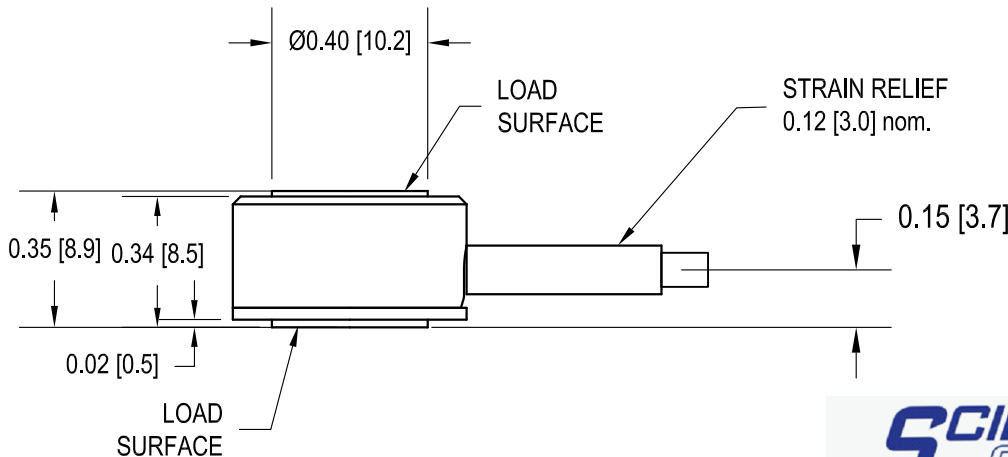
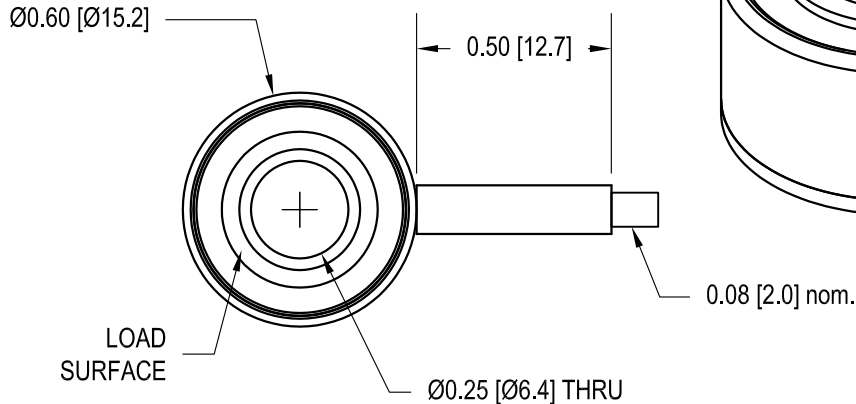
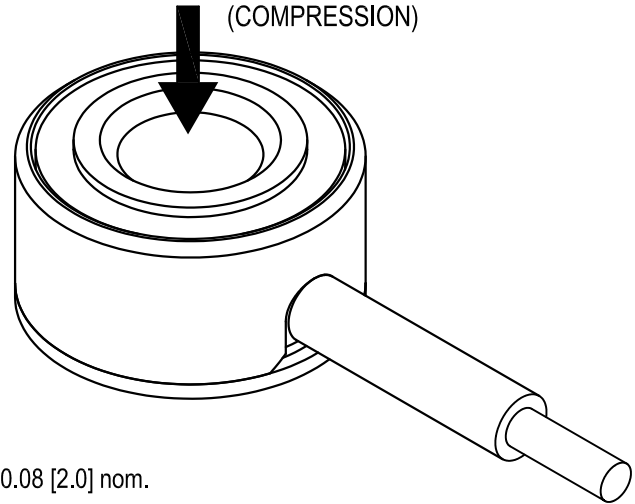

SCIGATE AUTOMATION (S) PTE LTD

No.1 Bukit Batok Street 22 #01-01 Singapore 659592

Tel: (65) 6561 0488

Fax: (65) 6562 0588

Email: sales@scigate.com.sg

Web: www.scigate.com.sg

Business Hours: Monday - Friday 8.30am - 6.15pm

SPECIFICATIONS:

RATED OUTPUT	3 mV/V nom.
CAPACITY $\frac{lb}{Kg}$	$\frac{2000}{907}$
SAFE OVERLOAD	150% of R.O.
ZERO BALANCE	$\pm 15\%$ of R.O.
EXCITATION (VDC OR VAC)	18 MAX
BRIDGE RESISTANCE	350 Ω nom.
TEMP. SHIFT ZERO	$\pm 0.02\%$ of R.O./ $^{\circ}F$ [0.036% of R.O./ $^{\circ}C$]
TEMP. SHIFT SPAN	$\pm 0.02\%$ of LOAD/ $^{\circ}F$ [0.036% of LOAD/ $^{\circ}C$]
COMPENSATED TEMP.	60 to 160 $^{\circ}F$ [15 to 72 $^{\circ}C$]
OPERATING TEMP.	-60 to 200 $^{\circ}F$ [-50 to 93 $^{\circ}C$]
WEIGHT	1 oz [30 g]
MATERIAL	17-4 PH STAINLESS STEEL
CABLE: #29 AWG, 4 CONDUCTOR, SPIRAL SHIELDED TEFLON CABLE 10 ft [3 m] LONG	
ACCESSORIES AND RELATED INSTRUMENTS AVAILABLE	
CALIBRATION (STD)	CERTIFICATE OF CONFORMANCE
CALIBRATION TEST EXCITATION	10 VDC

WARNING !!

THIS PRODUCT IS SENSITIVE TO INSTALLATION, MOUNTING AND SURFACE FLATNESS. RESULTS WILL GREATLY VARY FROM INSTALLATION TO INSTALLATION. FOR IMPROVED PERFORMANCE PLEASE REFERENCE THE LTH (DONUT / THRU HOLE) PRODUCT LINE.

FUTEK
ADVANCED SENSOR TECHNOLOGY, INC.

This drawing is submitted solely for the information and exclusive use of the original addressee. It is not to be divulged in whole or in part, by any firm or individual without written permission from FUTEK

10 THOMAS
IRVINE, CA 92618 USA
1-800-23-FUTEK (38835)

INTERNET:
<http://www.futek.com>