

FUTEK MODEL QLA248
STOCK NUMBER: QSH00645

FOLD BACK BENDING BEAM W/ OVERLOAD PROTECTION IN BOTH DIRECTIONS

INCH [mm]		R.O.= Rated Output	
WIRING CODE (WC1)			
+Excitation	-Excitation	+Signal	-Signal
RED	BLACK	GREEN	WHITE
Shield			
RING TERMINAL			

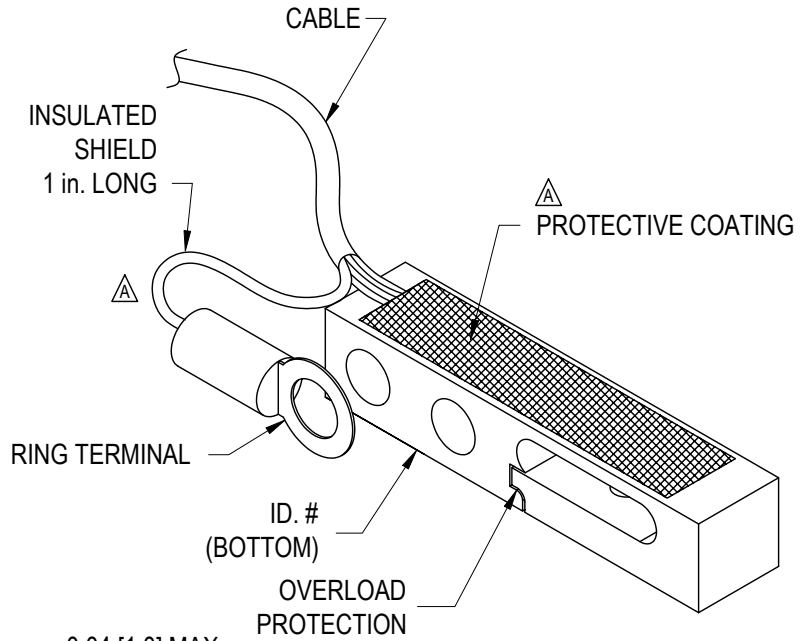
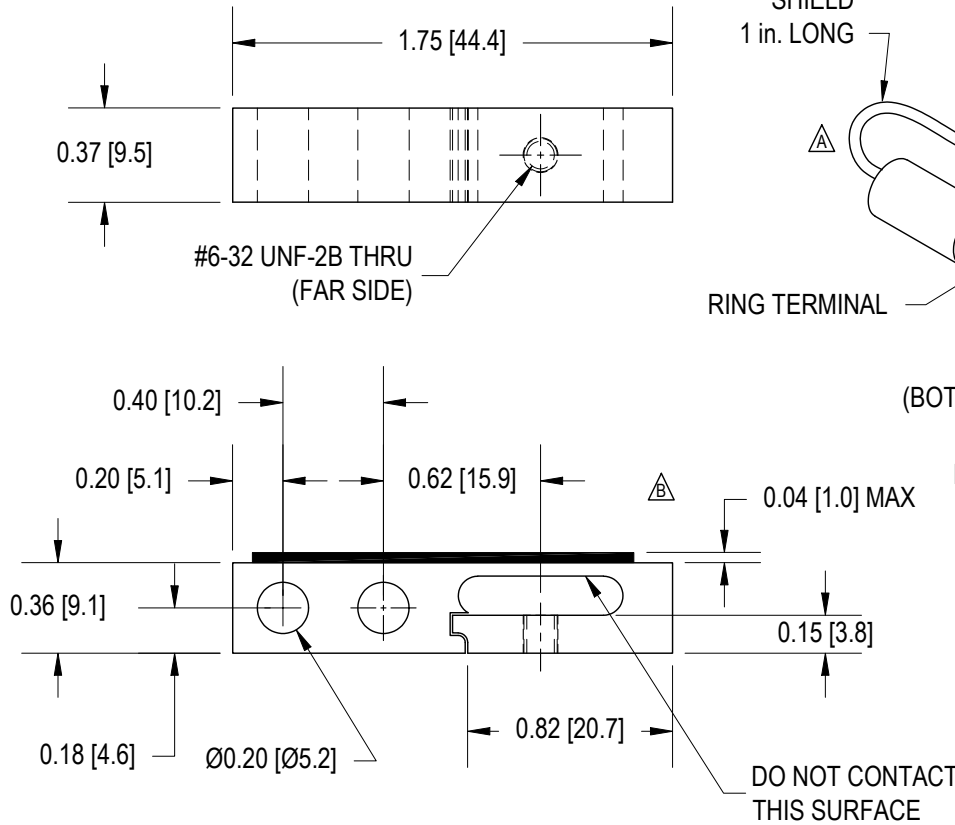

-OUTPUT
(COMPRESSION) ↑↓
+OUTPUT
(TENSION)

SPECIFICATIONS:

RATED OUTPUT	2.3 mV/V nom.
CAPACITY	10 lb [44.5 N]
SAFE OVERLOAD	1000% of R.O.
ZERO BALANCE	±1% of R.O.
EXCITATION (VDC OR VAC)	18 MAX
BRIDGE RESISTANCE	1000 Ω nom.
NONLINEARITY	±0.2% of R.O.
HYSTERESIS	±0.2% of R.O.
NONREPEATABILITY	±0.1% of R.O.
TEMP. SHIFT ZERO	±0.03% of R.O./°F [0.05% of R.O./°C]
TEMP. SHIFT SPAN	±0.03% of LOAD/°F [0.05% of LOAD/°C]
COMPENSATED TEMP.	60 to 160°F [15 to 72°C]
OPERATING TEMP.	-60 to 200 °F [-50 to 93 °C]
WEIGHT	3 oz [85 g]
MATERIAL	ALUMINUM
DEFLECTION	0.01 [0.25] nom.
CABLE:	#29 AWG, 4 Conductor, Spiral Shielded, Black Silicone Cable, 12 in. Long.
CALIBRATION (AVAILABLE)	5 pt TENSION; 150K Ω SHUNT CAL. VALUE
CALIBRATION TEST EXCITATION	10 VDC



SCIGATE AUTOMATION (S) PTE LTD
 No.1 Bukit Batok Street 22 #01-01 Singapore 659592
 Tel: (65) 6561 0488 Fax: (65) 6562 0588
 Email: sales@scigate.com.sg Web: www.scigate.com.sg
 Business Hours: Monday - Friday 8.30am - 6.15pm

MATERIAL:

—

HEAT TREATMENT - FINISH:

—

REVISIONS: (Refer to dwg # revision sheet)

- 10-24-05
- 12-22-05

OUTLINE DRAWING

STANDARD NOTES: (Unless Otherwise Specified)

- ALL DIMENSIONS ARE IN INCHES
- DRAWING INTERPRETATION DIMS. PER ASME-Y14.5M
- REMOVE BURRS AND BREAK SHARP EDGES .005 - .015
- THREADS PER HANDBOOK H-28
- DIMENSIONS ARE SHOWN AFTER PLATING

ANGLE: ±1/2°

CHAMFER: ±5°

TOLERANCE:
 .X ±0.1
 .XX ±0.01
 .XXX ±0.005

3rd ANGLE PROJ.



This drawing is submitted solely for the information and exclusive use of the original addressee. It is not to be divulged in whole or in part, by any firm or individual without written permission from:

FUTEK
 ADVANCED SENSOR TECHNOLOGY, INC.

10 THOMAS
 IRVINE, CA 92618 USA
 Phone: (949) 465-0900
 Fax: (949) 465-0905

CAGE: 1X8M6

MODEL: **QLA248**

DWG No.: **FO1112**

DRAWN BY: H. AU

CHECKED BY: J. MOKHBERY

APPROVED BY: J. VARGAS

DATE: **OCT, 19, 2005**