



More Precision

color**CONTROL** ACS7000 // Inline colour measuring system





- *Inline colour measurement*
- *Measurement without touching the sample*
- *Measurement precision $\Delta E \leq 0.08$*
- *Online colour measurement: 25Hz – 2,000Hz*
- *Ethernet/EtherCAT, RS 422, digital I/O*
- *Web browser operation*

- ▶ **Light source:** Adjustable “standard illuminant” and “standard observers”
- ▶ **Colour space:** XYZ; L*a*b*; L* u* v*; L*c*h; adjustable
- ▶ **Colour recognition** from a taught reference list
- ▶ **White/black reference comparison** (via browser and buttons on the device)
- ▶ **Inline quality assurance and continuous documentation**
- ▶ **Options:** measuring head geometries for different technical surfaces

The colorCONTROL ACS7000 inline colour measurement system not only recognises reference colours by comparison, but identifies individual colours clearly from their coordinates in the colour space. With its very high measurement speeds, the colorCONTROL ACS7000 is suitable for applications where colours and shades have to be examined on-the-fly and to very high accuracies. Because of its high measurement accuracy, the system is also used in laboratory tasks.

Measuring principle

The spectral procedure is the most accurate method of colour measurement. First, the sample is illuminated with a homogeneous white LED light. The spectrum of the reflected light is then calculated with a white reference. Then the coordinates in the CIE-XYZ colour system are determined for all wavelengths of visible light (390 to 780nm) and output in the desired colour space. The controller takes into account different observation conditions such as the type of light (illuminant) and standard observer.

Function

Three operating modes are possible with the colorCONTROL ACS7000: In the first mode, the colour distance ΔE is measured for reference. The system operates with up to 15 taught values. In the second mode, the reflectivity spectrum of the sample is determined and output. In the third mode, colour coordinates are determined and displayed in the desired colour space. For quality inspection purposes, a trend analysis can be carried out over any time period via the L*a*b*; XYZ or L*c*h colour values.

Measurements can be performed in all modes at speeds of up to 2kHz. Operation and display is via a Web interface. Light/dark correction can also be carried out using buttons on the controller or the user interface. Ethernet/EtherCAT, RS422 and digital I/Os are available for data output.

Controller colorCONTROL ACS7000	
Article number	11104174
Spectral measuring range	390 - 780 nm
Measuring range reflectivity	0 - 200 %R
Output values	L*a*b*, L*u*v*, L*c*h, XYZ, ΔE , spectrum
Illuminant	A, C, D65, D50, D75, E, F4, F7, F11, Off
Standard observer	2°, 10°
Distance models for colour recognition	Sphere (ΔE), cylinder (ΔL^* , Δa^*b^*), box (ΔL^* , Δa^* , Δb^*), with individual tolerance parameters for every colour taught
Colour resolution	0.01 ΔE
Spectral resolution	5nm
Measuring frequency	25 - 2,000Hz (internal spectrum, signal averaging and data reduction are possible)
Temperature stability	<0.1 $\Delta E/^{\circ}C$
Light source	LED, 390 - 780nm
Reproducibility of the measurements of a device ¹⁾	<0.03 (mean); <0.08 (max) ΔE
Housing dimensions	210x120x90mm (WxHxD)
Weight	1.8kg
Protection class	IP40
Operating temperature	0°C to 45°C
Storage temperature	-20°C to 70°C
Inputs / Outputs	Four colour detection switching outputs (4 individual colours or 15 colours binary or { ΔE , ΔL^* , Δa^* , Δb^* } for one colour) 1 Switching output, synchronisation 1 Switching input, synchronisation 1 Switching output, measurement error
Interfaces	Ethernet/EtherCAT (DHCP-enabled) RS422 (USB via RS422 adapter is possible)
Connection for fibre optics	Illumination: 7mm ferrule with M18 cap (union) nut (analogous to MICRO-EPSILON Eltrotec Fasop system) Measuring: DIN fibre connector
Connection cables	To power supply: Art. No. 11234222 / to PLC: Art. No. 11234223 / to synchronisation: Art. No. 11234091 / to PC: Art. No. 11294232 (Ethernet/EtherCAT); 11234224 or 11234230 (RS422)
Additional data processing	Internal calculation of spectral characteristics, colour valence calculations, colour space transformations, ΔE calculations, and tolerance settings of the upper and lower thresholds for the colour values
Connection to software	Control and configuration via integrated Web server or via terminal with commands Visualisation of spectral characteristics and temporal sequence of the colour values and colour differences
Power supply	24VDC +/- 15% 1000mA
Service life of the light source	>20,000h when operated at 25°C

¹⁾ Medium or maximum colour distance ΔE of 1000 successive measurements of the colour value (mean) of a light grey reference tile (R = 61%), measured with sensor FCS-T-ACS1-30/0-50-1200 at 200Hz and maximum illumination brightness

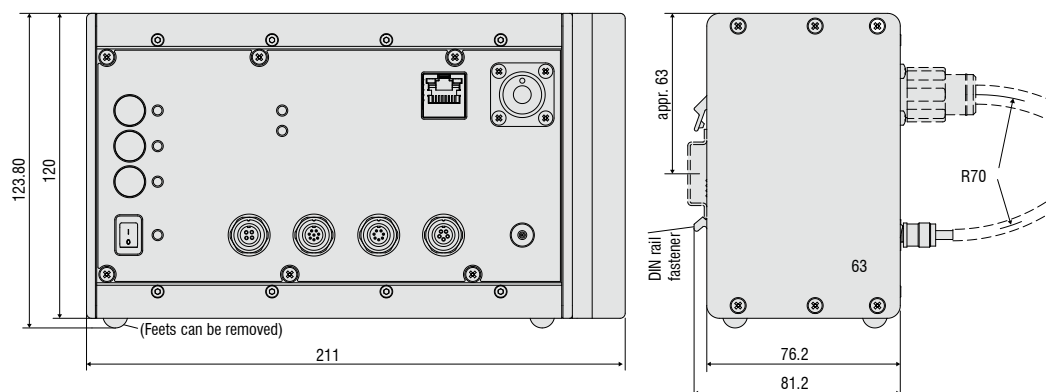



- For common measuring tasks
- Measurement distance: 38 or 50 mm
- Measurement geometry $45^\circ/0^\circ$ or $30^\circ/0^\circ$
- Measurement spot: $\varnothing 9\text{mm}$

The angle sensor ACS1 is used for common measuring tasks. The transmitter and the receiver inside the sensor are arranged at an angle of $45^\circ/0^\circ$ or $30^\circ/0^\circ$ to each other, producing a working distance of 38mm or 50mm.

An optionally available adapter permits applying the $30^\circ/0^\circ$ sensor even in tactile measurements.

Measurement geometry:

$30^\circ/0^\circ$; $45^\circ/0^\circ$

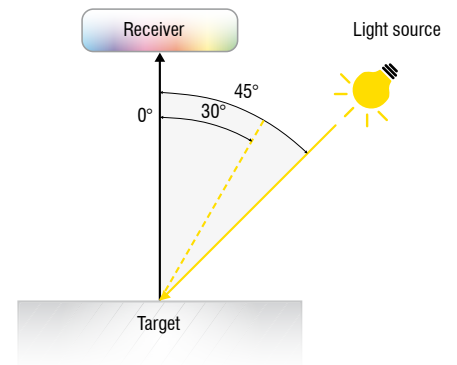

FCS-ACS1-30/0 adapter tactile

Article number 10824338

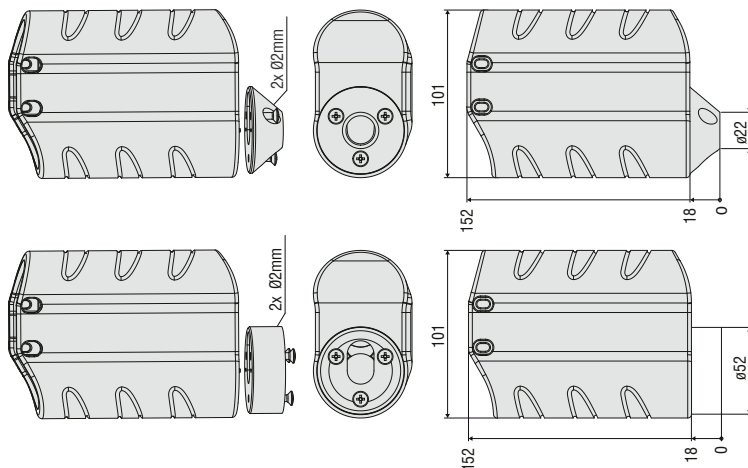

Fibre-optic sensor FCS-T	ACS1-30/0-50-1200	ACS1-45/0-38-1200
Article number	10824175	10824371
Measurement geometry (illumination / receiver)	30°/0°	45°/0°
Measuring spot diameter	9mm	9mm
Optimal measurement distance	50mm	38mm
Permissible measurement distance	±2mm of optimal measurement distance ($\Delta E < 1$)	±1mm of optimal measurement distance ($\Delta E < 1$)
Distance tolerance	0.5 ΔE /mm	1 ΔE /mm
Tilt angular tolerance	<0.3 ΔE /°	<1.33 ΔE /°
Ambient light tolerance at max. LED-performance ¹⁾	<0.5 ΔE /1000lux	<0.6 ΔE /1000lux
Dimensions	85x120x40mm	106x125x40mm
Weight (sensor incl. optical fibre)	420g	500g
Length of the optical fibre/sensor cable (optical-fibre cable)	1.2m (max 1.8m)	1.2m (max 1.8m)
Bending radius sensor cable	70mm	70mm
Protection class	IP64	IP64
Operating temperature	-20°C ... +70°C	-20°C ... +70°C
Storage temperature	-20°C ... +70°C	-20°C ... +70°C
Shock resistance	DIN EN 60068-2-29; 15g, 6ms	DIN EN 60068-2-29; 15g, 6ms
Vibration resistance	DIN EN 60068-2-6; 2g / 10Hz...500Hz	DIN EN 60068-2-6; 2g / 10Hz...500Hz

¹⁾ Measured at maximum illumination for reference tile (R = 61%) light grey with warm white external LED light source

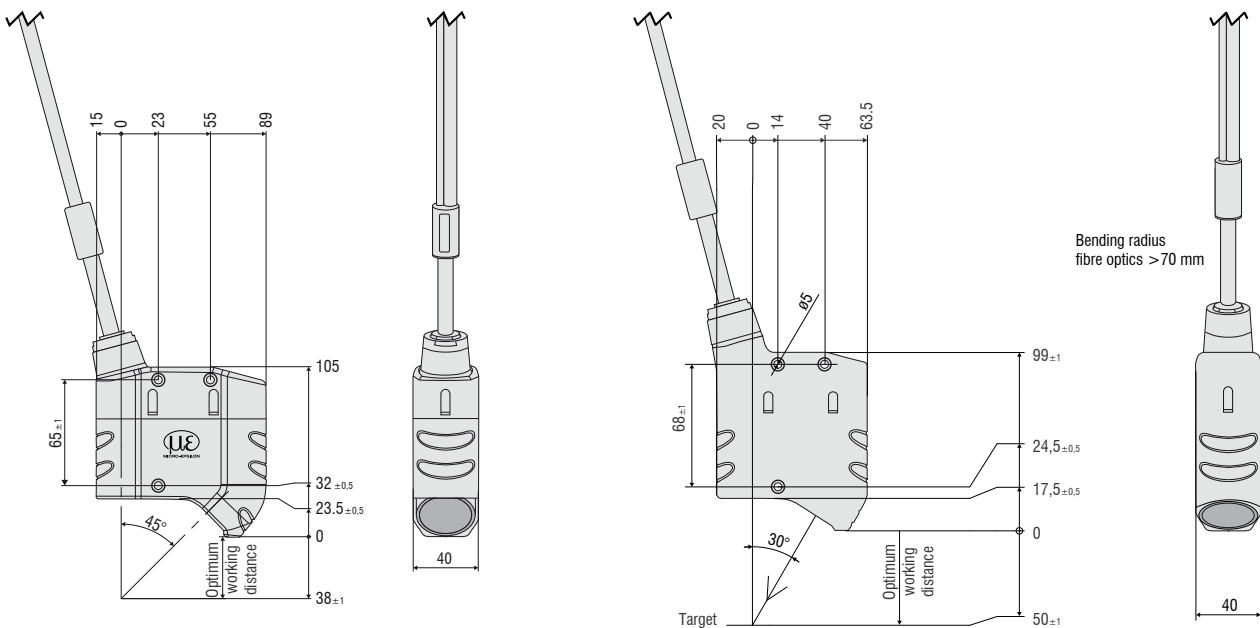



- Colour measurement of structured, highly reflective surfaces and lustrous metals
- Measurement distance: 28mm / 27.5mm
- Measurement geometry: 45° circular / 0°
- Measurement spot: $\varnothing 5\text{mm}$ / 3x2mm

The circular sensor ACS2 is used for colour measurement of structured and highly reflective surfaces as well as lustrous metals.

In the sensor, 24 lighting optics are circularly arranged around the receiving optics and provide a constant homogeneous lighting permitting that the measurement can be executed independently from the angular position of the measurement object.

This sensor enables as well to measure small measurement objects and curved surfaces.

Measurement geometry:

45° circular/0°

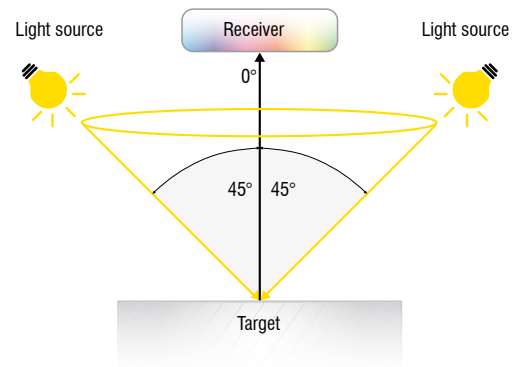

Fibre-optic sensor FCS-T	ACS2-R45/0-28-1200	ACS2-R45/0-28-1200(001)
Article number	10824370	10824370.001
Measurement geometry (illumination/receiver)	45° circular/0°	45° circular/0°
Measurement spot diameter	5mm (optional 9mm)	3 x 2mm
Optimal measurement distance	28mm	27.5mm
Permissible measurement distance	±1mm of optimal measurement distance ($\Delta E < 1$)	+1,5mm / -0,7mm
Distance tolerance	1 ΔE /mm	1 ΔE /mm
Tilt angular tolerance	<0.3 ΔE /°	<0.3 ΔE /°
Ambient light tolerance at max. LED-performance	<0.3 ΔE /1000lux	<0.3 ΔE /1000lux
Dimensions	Ø115x65mm	Ø115x65mm
Weight (sensor incl. optical fibre)	822g	822g
Length of the optical fibre/sensor cable (optical-fibre cable)	1.2m (max 1.8m)	1.2m (max 1.8m)
Bending radius sensor cable	70mm	70mm
Protection class	IP64	IP64
Operating temperature	-20 °C ... +70 °C	-20 °C ... +70 °C
Storage temperature	-20 °C ... +70 °C	-20 °C ... +70 °C
Shock resistance	DIN EN 60068-2-29; 15g, 6ms	DIN EN 60068-2-29; 15g, 6ms
Vibration resistance	DIN EN 60068-2-6; 2g / 10Hz...500Hz	DIN EN 60068-2-6; 2g / 10Hz...500Hz

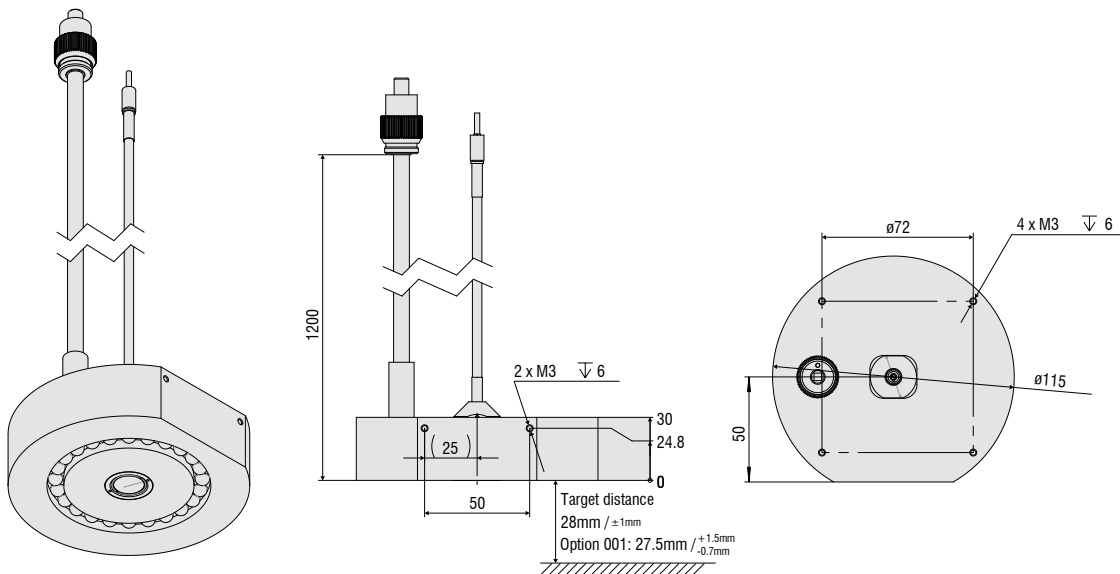

ACS2-R45/0-28-1200(001)

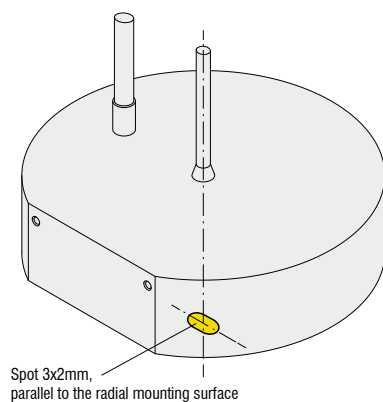

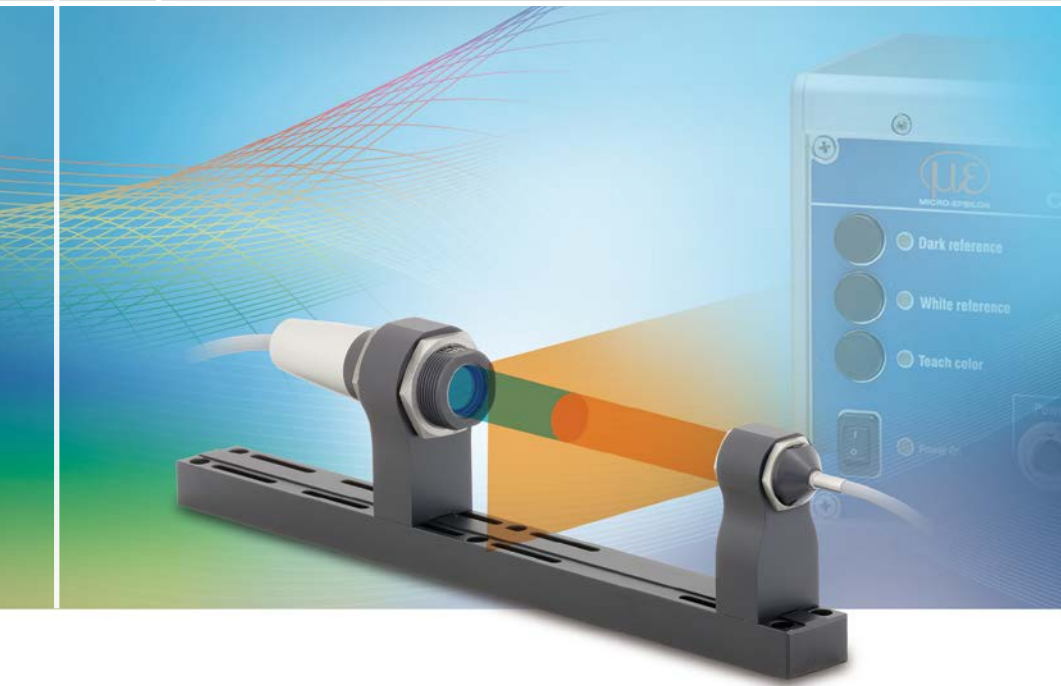

- Measurement of self-luminous and transparent objects
- Measurement distance: max 300mm
- Measurement geometry: transmission
- Measurement spot: $\varnothing 5 / \varnothing 9\text{mm}$ (at a measurement distance up to 200mm)

The transmission sensor ACS3 is used to measure self-luminous and transparent objects like foil, glass and Plexiglas. For the colour measurement of self-luminous objects, only a receiver unit is required. Measuring transparent objects requires transmitter (TT) and receiver unit (TR) which can be installed with a mounting set.

Measurement geometry:

Transmission

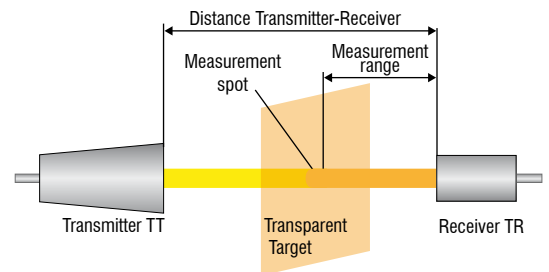

FCS-ACS3-200 mounting rail

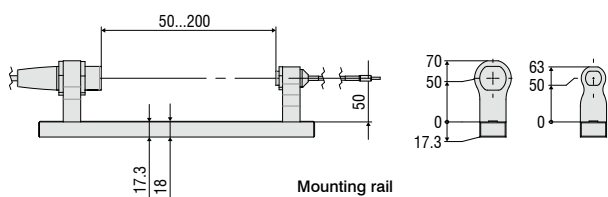
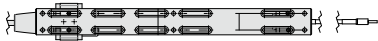

Mounting rail
Art.-No. 10824414

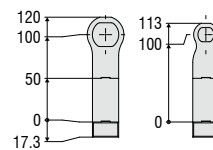

FCS-ACS3 mounting adapter 50mm
Art.-No. 10824423

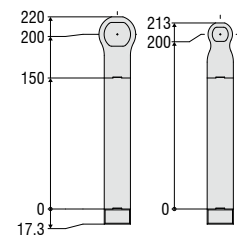

FCS-ACS3 mounting adapter 150mm
Art.-No. 10824422

Fibre-optic sensor FCS-T	ACS3-TR5-200-1200	ACS3-TR9-200-1200	ACS3-TT15-200-1200
Article number	10824411	10824412	10824413
Measurement geometry (illumination/receiver)	Receiver	Receiver	Transmitter
Measurement spot diameter	5mm for <100mm ¹⁾	9 mm for <200mm ¹⁾	15mm for 200mm ⁵⁾
Optimal measurement distance	10 ... 100mm ^{2) 3)}	10 ... 200mm ^{2) 3)}	10 ... 200mm
Permissible measurement distance	10 ... 200mm ^{2) 3)}	10 ... 300mm ^{2) 3)}	10 ... 300mm
Distance tolerance ⁴⁾	<0.01 $\Delta E/mm$ ⁶⁾ <0.005 $\Delta E/mm$ ²⁾	<0.01 $\Delta E/mm$ ⁶⁾ <0.005 $\Delta E/mm$ ²⁾	-
Tilt angular tolerance ⁴⁾	<0.05 $\Delta E/^\circ$	<0.05 $\Delta E/^\circ$	-
Ambient light tolerance at max. LED-performance	<0.05 $\Delta E/1000lux$	<0.05 $\Delta E/1000lux$	-
Dimensions	Ø22x40mm	Ø22x40mm	Ø30x96mm
Weight (sensor incl. optical fibre)	70g	70g	220g
Length of the optical fibre/sensor cable (optical-fibre cable)	1.2m (max. 30m)	1.2m (max. 30m)	1.2m (max. 1.8m)
Bending radius sensor cable	70mm	70mm	70mm
Protection class	IP 64	IP 64	IP 64
Operating temperature	-20°C ... +70°C	-20°C ... +70°C	-20°C ... +70°C
Storage temperature	-20°C ... +70°C	-20°C ... +70°C	-20°C ... +70°C
Shock resistance	DIN EN 60068-2-29; 15g, 6ms		
Vibration resistance	DIN EN 60068-2-6; 2g / 10Hz...500Hz		

¹⁾ Measurement spot diverges with growing distance between receiver and target

²⁾ Valid in combination with ACS3-TT15-200 for the transmission measurement (transmitted light)

³⁾ When measuring the transmission, the "optimal measurement distance" and the "permissible measurement distance" refer to the distance between transmitter and receiver. The sample can be at any position within the light curtain between transmitter and receiver.

⁴⁾ Tilt angular tolerance and distance tolerance were determined in transmission with different colour glass filters (thickness 2.5 mm, refraction index 1.5).

When measuring the illumination (only receiver), these were determined with uniformly illuminated (Lambertian) diffuser by tilting the transmitter towards the receiver.

⁵⁾ Illumination spot diameter

⁶⁾ When using it as receiver sensor for illumination measurement

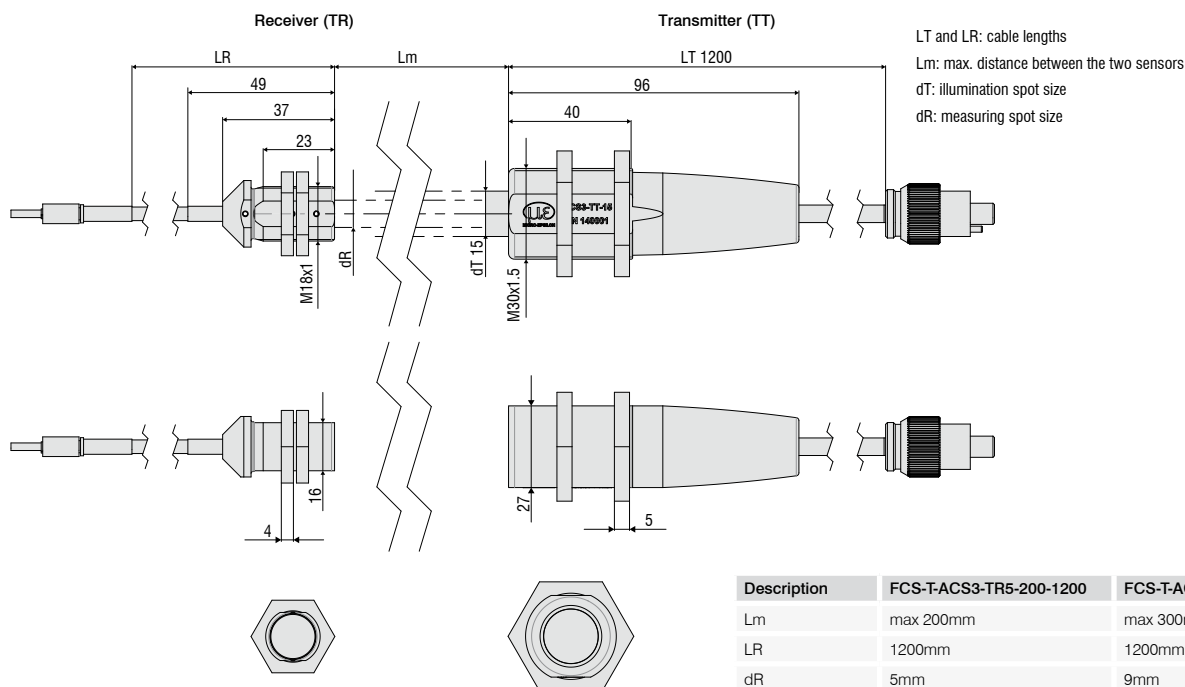

Spectrum and colour coordinate in the user interface

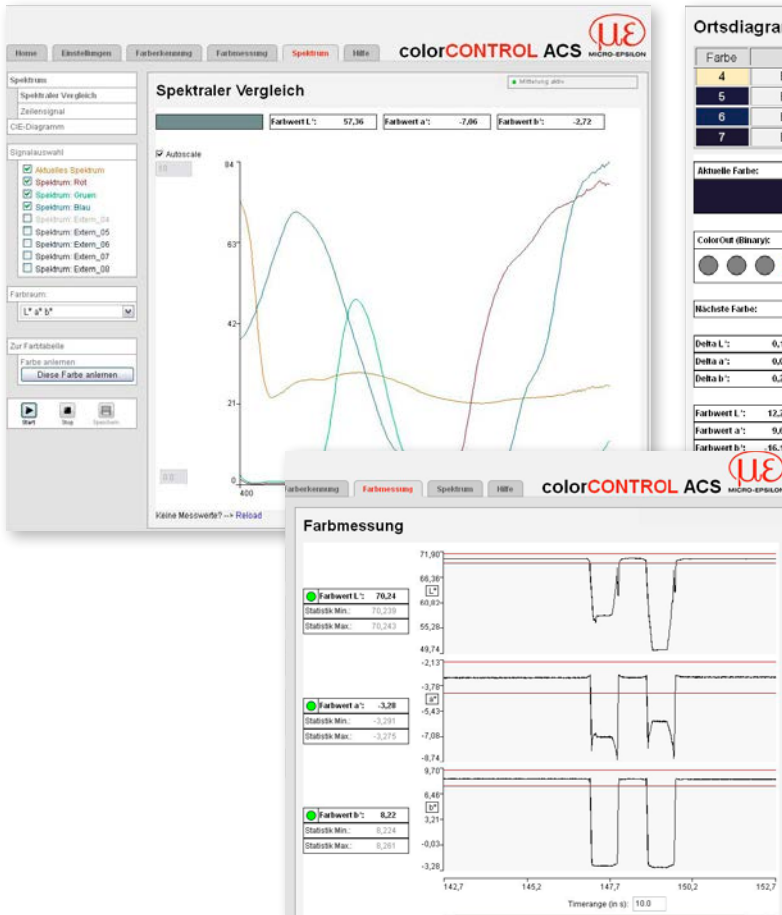

Depiction of colour values in the colour space

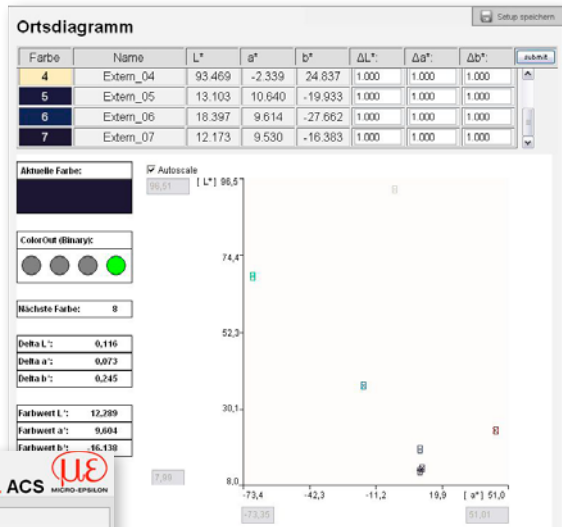

Measurements of XYZ, L*a*b*, L*u*v*, L*c*h shown over time

Applications:

- Inline measurement in production lines, all industries: Plastics, wood, paper, film and foil, injection moulding, textiles and pharmaceuticals
- Interior colour measurement
- Inspection of car paint

Benefits:

- Continuous process measurement to ensure consistent product quality
- Direct influence on the production process is possible
- Lower cost production
- Minimisation of waste and rejects



Inline measurement of the colour gradient of glass, Plexiglas, PET and PVC foils, paper.



Measurement of the zinc sheet colour.



Interior and attachment parts in the automotive industry.



colorCONTROL ACS accessories

Art. no.	description	suitable for:
11234274	reflectance standard 1.25" Fluorilon	colorSENSOR and colorCONTROL
11234222	CAB-M9-4P-co-straight; 2m-PUR; open ends	colorCONTROL ACS7000 (power)
11234225	CAB-M9-4P-co-straight; 5m-PUR; open ends	colorCONTROL ACS7000 (power)
11234091	CAB-M9-8P-co-straight; 2m-PUR; open ends	colorCONTROL ACS7000 (digital I/O, Sync.)
11234099	CAB-M9-8P-co-straight; 5m-PUR; open ends	colorCONTROL ACS7000 (digital I/O, Sync.)
11234223	CAB-M9-7P-co-straight; 2m-PUR; open ends	colorCONTROL ACS7000 (colour Out)
11234226	CAB-M9-7P-co-straight; 5m-PUR; open ends	colorCONTROL ACS7000 (colour Out)
11294232	CAB-RJ45-Eth; 2m-PVC-Cat5e; RJ45-Eth	colorCONTROL ACS7000 (Ether-net/-CAT)
11293257	CAB-RJ45-Eth; 5m-PVC-Cat5e; RJ45-Eth	colorCONTROL ACS7000 (Ether-net/-CAT)
11294277	CAB-RJ45-Eth-Cross; 3m-PVC-Cat5e; RJ45-Eth	colorCONTROL ACS7000 (Ether-net/-CAT)
11293258	CAB-RJ45-Eth-Cross; 5m-PVC-Cat5e; RJ45-Eth	colorCONTROL ACS7000 (Ether-net/-CAT)
11234224	CAB-M9-5P-co-straight; 2m-PVC-RS422; open ends	colorCONTROL ACS7000 (RS422)
11234227	CAB-M9-5P-co-straight; 5m-PVC-RS422; open ends	colorCONTROL ACS7000 (RS422)
11234230	CAB-M9-5P-co-straight; 2m-PVC-RS422; Sub-D-15P-co-straight	colorCONTROL ACS7000 (IF2008)
11234231	CAB-M9-5P-co-straight; 5m-PVC-RS422; Sub-D-15P-co-straight	colorCONTROL ACS7000 (IF2008)
2213017	IF2008 Interface card RS422 / PCI-card	colorCONTROL ACS7000 (RS422/PC)
10824338	FCS-ACS1-30/0 adapter tactile	FCS-X-ACS1-30/0-50-XXXX
10824424	FCS-ACS adapter TT-TR	all ACS sensor heads (connection illumination into receiving fibres)
10824414	FCS-ACS3-200 mounting rail	FCS-X-ACS3
10824423	FCS-ACS3 mounting adapter 50mm	FCS-ACS3-200 mounting rail
10824422	FCS-ACS3 mounting adapter 150mm	FCS-ACS3-200 mounting rail
2420065	PS2030 power supply 24V/24W/ 1A; 2m-PVC; terminal-2P-co-fm-straight	CAB-M9-4P-co-straight; Xm-PUR; open ends (Power)

Pin assignment

CAB-M9-5P-co-straight; Xm-PVC-RS422;

open ends
(Art. no.: 11234224; 11234227)
Connection cable RS422
(max. length 5m, sheath PVC)

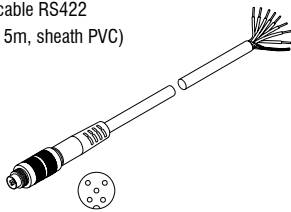

Pin	Colour	ACS7000
1	white	TX
2	brown	/TX
3	green	/RX
4	yellow	RX
5	grey	GND RS422 DC-isolated

CAB-M9-8P-co-straight; Xm-PUR;

open ends
(Art. no.: 11234091; 11234098)
Connection cable to power/PLC or digital I/O
(max. length. 10m, sheath PUR)

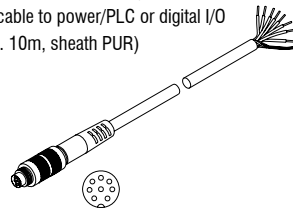

Pin	Colour	ACS7000
1	white	Error
2	brown	GND Error
3	green	Sync. OUT
4	yellow	GND Sync. OUT
5	grey	Sync. IN
6	pink	GND Sync. IN
7	blue	LLL/HLL
8	red	LLL/HLL

CAB-M9-7P-co-straight; Xm-PUR;

open ends
(Art. no.: 11234223; 11234226)
Connection cable colour OUT
(max. length 10m, sheath PUR)

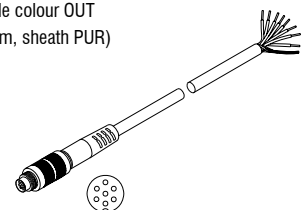

Pin	Colour	ACS7000
1	white	OUT 0
2	brown	OUT 1
3	green	OUT 2
4	yellow	OUT 3
5	grey	GND
6	pink	n.c.
7	blue	n.c.

CAB-M9-4P-co-straight; Xm-PUR;

open ends
(Art. no.: 11234222; 11234225)
Connection cable to power
(max. length. 10m, sheath PUR)

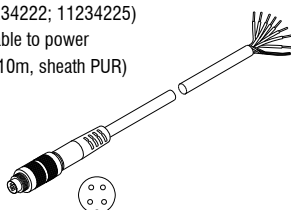

Pin	Colour	ACS7000
1	white	n.c.
2	brown	+24V DC (±15%)
3	black	n.c.
4	blue	GND (0V)

High performance sensors made by Micro-Epsilon



Sensors and systems for displacement and position



Sensors and measurement devices for non-contact temperature measurement



2D/3D profile sensors (laser scanner)



Optical micrometers, fibre optic sensors and fibre optics



Colour recognition sensors, LED analyzers and colour inline spectrometer



Measurement and inspection systems



SCIGATE AUTOMATION (S) PTE LTD

No. 1 Bukit Batok Street 22 #01-01 Singapore 659592

Tel: (65) 6561 0488

Fax: (65) 6562 0588

Email: sales@scigate.com.sg

Web: www.scigate.com.sg

Business Hours: Monday - Friday 8.30am - 6.15pm



MICRO-EPSILON Eltrotec GmbH

Heinkelstraße 2 · 73066 Uhingen / Germany

Tel. +49 (0)7161 98872-300 · Fax+49 (0)7161 98872-303

eltrotec@micro-epsilon.de · www.micro-epsilon.com