



More Precision

eddyNCDT // Eddy current sensors for displacement and position





- Easy sensor replacement
- Configuration via web browser
- High temperature stability, resolution and linearity
- Frequency response 25 kHz (-3dB)
- Multi channel applications: synchronisation of up to 10 controller

System design

The eddyNCDT 3100 includes an extremely compact controller and a displacement sensor. The sensors are connected through a 3m or 9m integrated, highly flexible cable and connected to the controller by a user-friendly push-pull plug-in connection.

The controller housing is made from solid cast aluminium and is protected to IP65. Alternative mounting options are slot nuts, mounting holes or a mounting rail. The robust sensors make the eddyNCDT 3100 system ideally suited to measurement tasks in the industrial environment.

Versatile in application

The eddyNCDT 3100 series is the new generation of eddy current displacement measurement systems. The measurement system uses a patented temperature compensation method to provide firstclass stability even with fluctuating temperatures. These sensors are an excellent choice when you need high precision in harsh industrial environments (pressure, dust, temperature).

Sensors and cables come with an integrated memory module that stores all the major sensor and cable data. All sensors are factory calibrated to adjust to ferromagnetic and non-ferromagnetic materials.

Multi-channel synchronisation

In the case that more sensors of the series eddyNCDT 3100 are operated next to each other, an influence due to a hardly different oscillator frequency (beat frequency) is possible. This can be avoided by synchronisation. The eddyNCDT 3100-SM is equipped with two additional connectors for the oscillator output („SYNC OUT“) and for the input („SYNC IN“). The electronics is working independently until a connection is built. By means of the connections with the synchronisation cable SC3100-0,3, the electronics switch automatically to synchronisation mode. In this way, two up to ten systems can be synchronised with each other.



All settings are made in the intuitive web interface, eliminating the need for any special software.

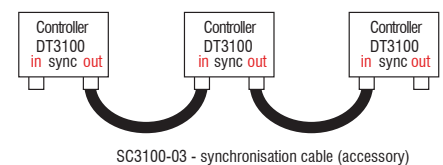

Controller	DT3100	
Linearity	$\pm 0.25\% \text{ FSO}$	
Resolution ¹⁾	0.005 % FSO	
Frequency response	voltage output: 25kHz (-3dB)	
	digital (Ethernet): 14.4kHz; 7.2kHz; 3.6kHz (each 16 bit)	
Temperature compensation range	standard: 10 ... 65 °C	
Temperature range	controller	operation: 10 ... 50 °C
Temperature stability	controller (MMR)	0.05 % FSO / °C
Outputs	0 ... 10 V / - 5 ... + 5 V / 4 ... 20 mA / Ethernet	
Power supply	24 VDC (11 ... 30V) / ca. 5W	
Synchronisation	only DT3100-SM	via cable SC 3100-0,3 (accessories)
Protection class	controller	IP65 (connected plug-in connections/covers)

FSO = of full scale output

MMR = midrange

¹⁾ Static resolution, relates to centre of measuring range; effective value (RMS)

Controller housing DT3100 / DT3100-SM

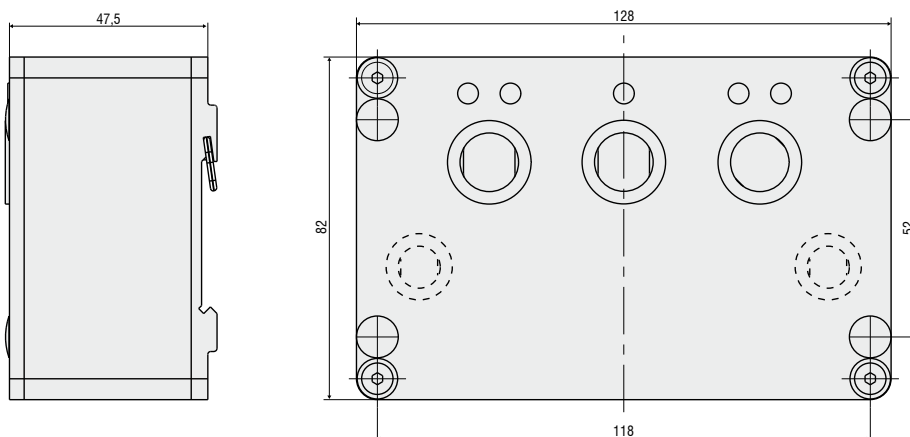

▲▲▲▲
Measurement direction

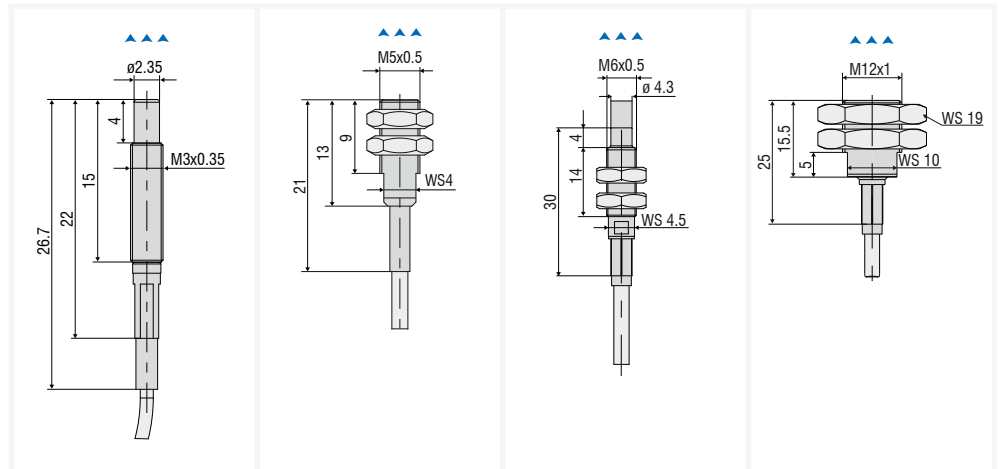

Sensor type	EPU05	EPS08	EPU1	EPS2
Design	unshielded	shielded	unshielded	shielded
Measuring range	0.5mm	0.8mm	1mm	2mm
Offset distance	0.05mm	0.08mm	0.1mm	0.2mm
Linearity	$\leq \pm 1.25\mu\text{m}$	$\leq \pm 2\mu\text{m}$	$\leq \pm 2.5\mu\text{m}$	$\leq \pm 5\mu\text{m}$
Resolution	$0.025\mu\text{m}$	$0.04\mu\text{m}$	$0.05\mu\text{m}$	$0.1\mu\text{m}$
Temperature stability (MMR)	$\leq \pm 0.25\mu\text{m}/^\circ\text{C}$	$\leq \pm 0.4\mu\text{m}/^\circ\text{C}$	$\leq \pm 0.5\mu\text{m}/^\circ\text{C}$	$\leq \pm 1\mu\text{m}/^\circ\text{C}$
Temperature max.	100°C	100°C	100°C	100°C
Protection class (front and rear)	IP67	IP67	IP67	IP67
Integrated cable/ length	3m	3m	3m/9m	3m/9m
Temperature sensor cable	100°C	100°C	100°C	100°C
Housing material	stainless steel and ceramic	stainless steel and plastic	stainless steel and plastic	stainless steel and plastic

MMR = midrange

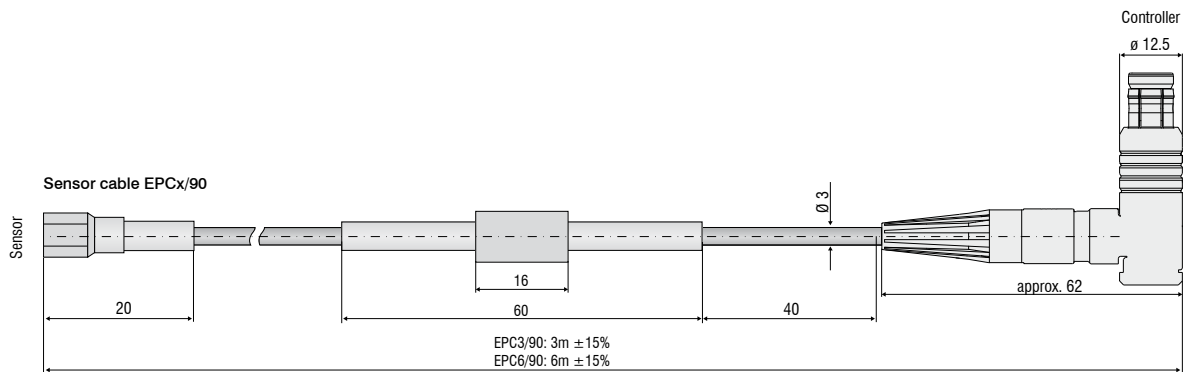
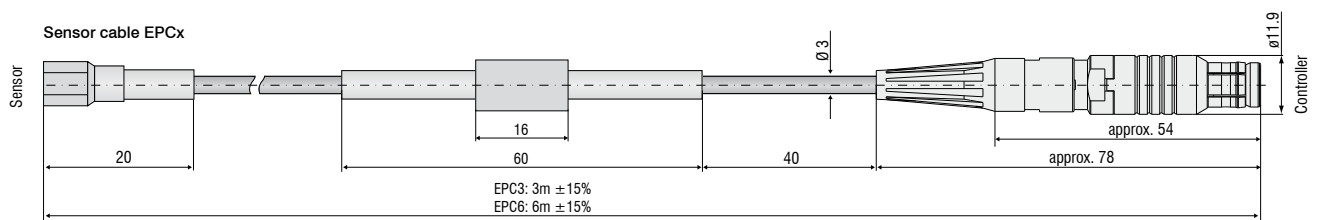

▲▲▲▲
Measurement direction

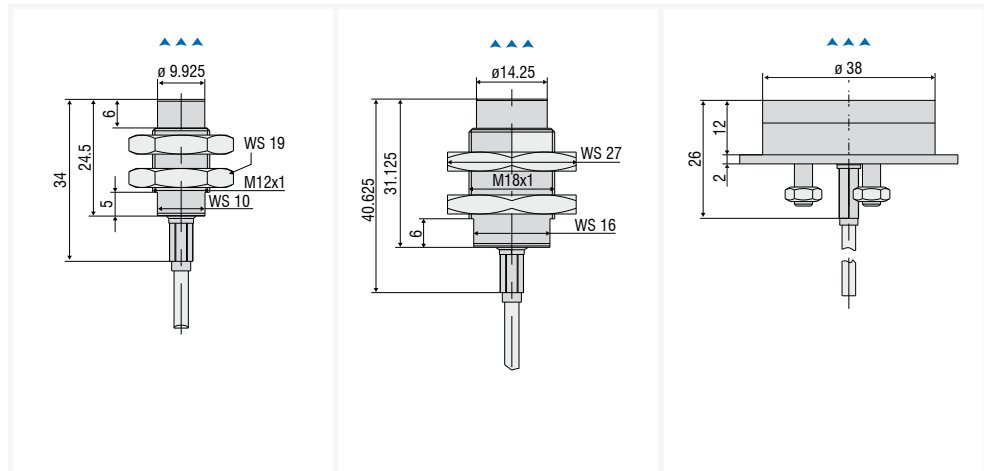

Sensor type	EPU3	EPU6	EPU15
Design	unshielded	unshielded	unshielded
Measuring range	3mm	6mm	15mm
Offset distance	0.3mm	0.6mm	1.5mm
Linearity	$\leq \pm 7.5\mu\text{m}$	$\leq \pm 15\mu\text{m}$	$\leq \pm 37.5\mu\text{m}$
Resolution	0.15 μm	0.3 μm	0.75 μm
Temperature stability (MMR)	$\leq \pm 1.5\mu\text{m}/^\circ\text{C}$	$\leq \pm 3\mu\text{m}/^\circ\text{C}$	$\leq \pm 7.5\mu\text{m}/^\circ\text{C}$
Temperature max.	100°C	100°C	100°C
Protection class (front and rear)	IP67	IP67	IP67
Integrated cable/ length	3m/9m	3m/9m	3m/9m
Temperature sensor cable	100°C	100°C	100°C
Housing material	stainless steel and plastic	stainless steel and plastic	epoxy

MMR = midrange

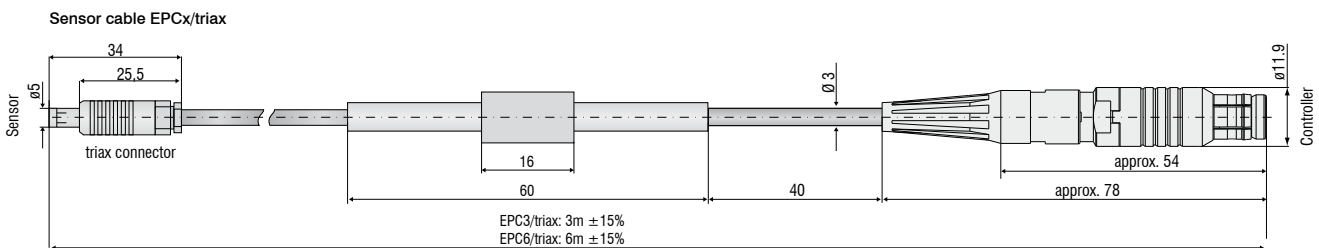

Cable

Cable design: coaxial
 Sheath material: TPE-U/ thermoplastic elastomers
 Temperature resistance: -40°C to +90°C
 Outer diameter: 2.90mm ±0.2mm
 Length tolerance: ±15%
 Bending radius: one-time bending during installation: 7.5 x cable diameter
 minimum bending radius for movement: 15 x cable diameter
 Suitable for use with robots: no

Plug Model

Type: 6-pole male connector
 Locking method: push-pull
 Protection class: IP68 (when connected)
 Temperature resistance: -40 to +120°C
 Material housing: Copper, nickel-plated
 Mechanical service life: > 500 mating cycles

Controller side

6-pole male connector
 push-pull
 IP68 (when connected)
 -40 to +120°C
 Copper, nickel-plated
 > 500 mating cycles

Sensor side

EPCx / EPCx/90
 female connector, coaxial, SMC screw
 no details
 -65 to +165°C
 Brass, gold plated
 > 500 mating cycles

EPCx/triax

male connector, triaxial push-pull
 IP67 (when connected)
 -30 to +150°C
 Brass nickel-plated, mat
 > 500 mating cycles

Article	Description	eddyNCDT 3001	eddyNCDT 3005	eddyNCDT 3010	eddyNCDT 3100	eddyNCDT 3300
PC3/8	Power- and output cable, 3m, 8 pin			•		
PC5/5	Power- and signal cable	•	•			
SC30	Synchronisation cable, 30cm			•		
CSP 301	Digital signal processing and display unit up to 2 channels			•		
PC3100-3/6/BNC	Output cable and supply unit, 3m				•	
PS2020	Power Supply 24V / 2.5A; Input 100-240 VAC; Output 24 VDC / 2.5A; DIN rail mounting; 35mm x 7.5mm, DIN 50022				•	•
MC2.5	Micrometer calibration fixture, range 0 to 2.5 mm, division 1 μ m, for sensors EPU05 to EPS2, adjustable offset (zero)			•	•	•
MC25D	Micrometer calibration fixture, range 0 to 25mm, division 1 μ m, for sensors EPU05 to EPU15, adjustable offset (zero)			•	•	•
ECx	Sensor cable, length selectable up to 15m					•
ECx/90	Sensor cable with 90° connector (sensor-sided) length selectable up to 15m					•
ECx/1	Extension cable for solder connection					•
ECx/2	Extension cable for plug connection					•
SCA3/5	Signal cable analogue, 3m					•
SCA3/5/BNC	Signal cable analogue with BNC connector, 3m					•
SCD3/8	Signal cable digital (switch input/output), 3m (also for supply 11 - 32VDC); for DT3301					•
SIC3(07)	Signal cable with BNC connector for direct operation with oscilloscope					•
PSC30	Power / Synchronisation cable, 0.3m, for DT3300					•
ESC30	Synchronisation cable, 0.3m, for DT3301					•
PS300/12/5	Power supply Input 100 - 240VAC; Output \pm 12VDC / 5.2VDC integrated cable 1.5m; for max. 4x DT3300					•
MBC300	Mounting base for controller DT330x, fixing through M4 threaded holes 166x108x60mm					•
MCT304-SM	Tower for max. 4 controller DT 3300; supply 100 - 240VAC					•
MCT304(01)	Tower for max. 4 controller DT 3301; supply 11 - 32VDC					•

High performance sensors made by Micro-Epsilon



Sensors and systems for displacement and position



Sensors and measurement devices for non-contact temperature measurement



2D/3D profile sensors (laser scanner)



Optical micrometers, fibre optic sensors and fibre optics



Colour recognition sensors, LED analyzers and colour online spectrometer



Measurement and inspection systems

