

SMALL TYPE FLOAT SWITCH

All-purpose Float Switch of Compact-size



Ideal for a small tank!!
Highly sophisticated model of Compact Float Switch
applicable to multipurpose!!

ONE-POINT-MEASUREMENT

Material: Stainless Steel

RFS-2

Standard Type

Heat-proof Temperature
MAX.120°C

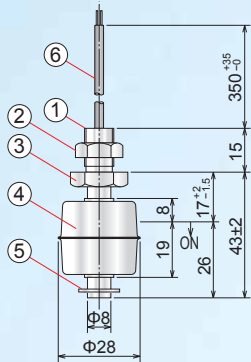

No.	Parts name	Material	Qty
1	Process Connection	G 1/8B	
2	Nut	304SS	1
3	Main body	304SS	1
4	Float	304SS	1
5	Stopper	304SS	1
6	Lead wire	AWG22	2



RFS-6

High Temperature(Heat-proof) Type

Heat-proof Temperature
MAX.200°C

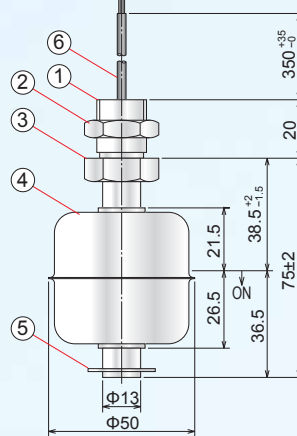

No.	Parts name	Material	Qty
1	Process Connection	G 3/8B	
2	Nut	304SS	1
3	Main body	304SS	1
4	Float	304SS	1
5	Stopper	304SS	1
6	Lead wire	AWG22	2



RFS-11A

Horizontal-mounting Type

Heat-proof Temperature
MAX.120°C

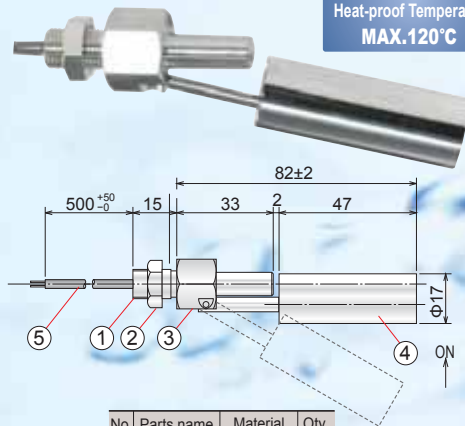

No.	Parts name	Material	Qty
1	Process Connection	G 1/8B	
2	Nut	304SS	1
3	Main body	304SS	1
4	Float	304SS	1
5	Lead wire	AWG22	2



SMALL TYPE
FLOAT SWITCH

RFS-4

L-shape Horizontal-mounting Type

Heat-proof Temperature
MAX.120°C

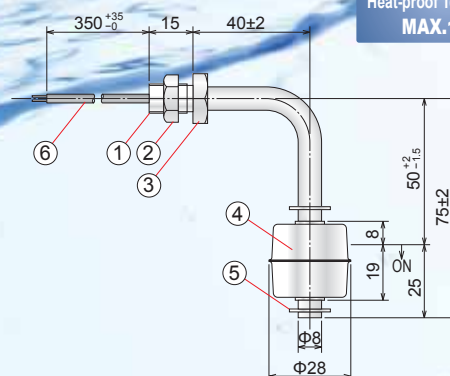

No.	Parts name	Material	Qty
1	Process Connection	G 1/8B	
2	Nut	304SS	1
3	Main body	304SS	1
4	Float	304SS	1
5	Stopper	304SS	1
6	Lead wire	AWG22	2

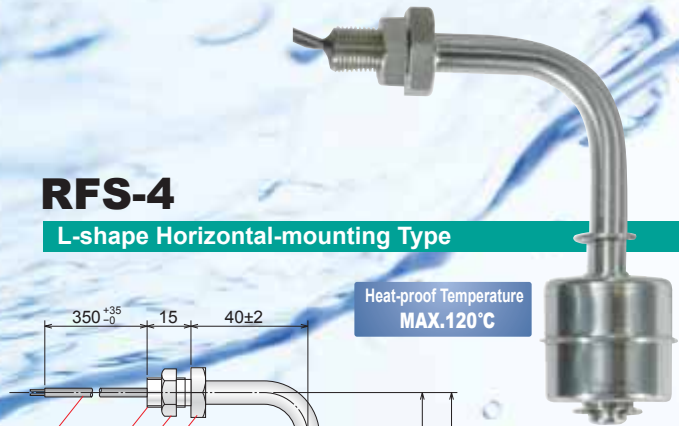

ONE-POINT-MEASUREMENT

Material: Polypropylene

MFS17-C

Standard Type

Heat-proof Temperature
MAX.80°C

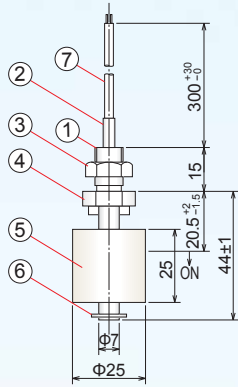

No.	Parts name	Material	Qty
1	Process Connection	G 1/8B	
2	Protective tube	Vinyl	1
3	Nut	P.P.	1
4	Main body	P.P.	1
5	Float	P.P. Foamed	1
6	Stopper	304SS (P.P.)	1
7	Lead wire	AWG22	2



MFS17-D

Compact Float Type

Heat-proof Temperature
MAX.80°C

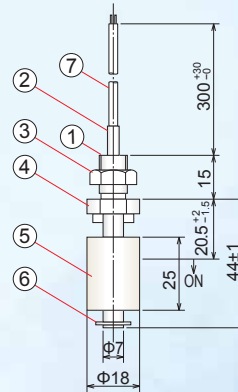

No.	Parts name	Material	Qty
1	Process Connection	G 1/8B	
2	Protective tube	Vinyl	1
3	Nut	P.P.	1
4	Main body	P.P.	1
5	Float	P.P. Foamed	1
6	Stopper	304SS (P.P.)	1
7	Lead wire	AWG22	2



All-purpose Float Switch of Compact-size
Abundant models can delicately respond to diversified environments.

●The simple structure makes your handling easier.●Few failures come up with the longer life.

MFS9-N1

Horizontal-mounting Type (Process Connection G 1/4B)

Heat-proof Temperature
MAX.80°C

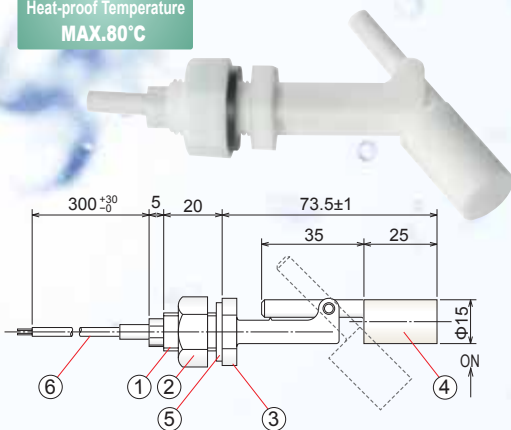

No.	Parts name	Material	Qty
1	Process Connection	G 1/4B	
2	Nut	P.P.	1
3	Main body	P.P.	1
4	Float	P.P. Foamed	1
5	Packing	EPT	1
6	Lead wire	AWG22	2

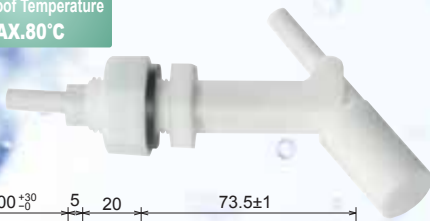

MFS10-N1

Horizontal-mounting Type (Process Connection NPT 1/2)

Heat-proof Temperature
MAX.80°C

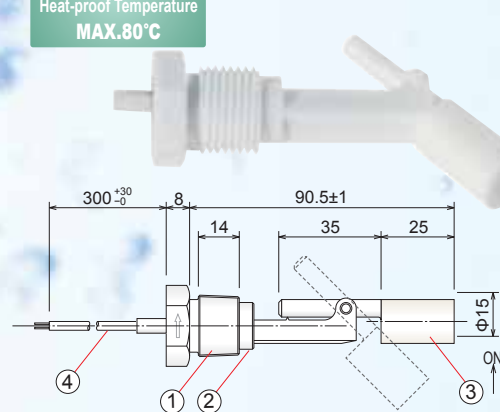

No.	Parts name	Material	Qty
1	Process Connection	NPT1/2	
2	Main body	P.P.	1
3	Float	P.P. Foamed	1
4	Lead wire	AWG22	2

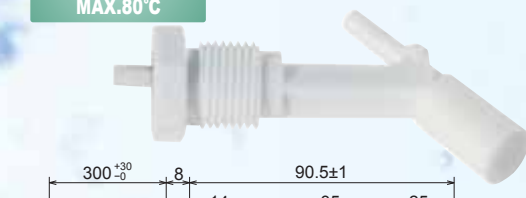

MULTI-POINT MEASUREMENT

With Terminal box

KS30

Material : Stainless steel

Heat-proof Temperature
MAX.100°C



Process Connection	Flange JIS5K32A 304SS
Float	Φ30*30 304SS
Stopper	304SS
Liquid Density	Over 0.75
Max Switching Capacity	AC50VA DC50W

(Detection point 1 - 5)

KS30TH

Material : Stainless steel

Heat-proof Temperature
MAX.200°C



Process Connection	Flange JIS5K50A 304SS
Float	Φ51*40 304SS
Stopper	304SS
Liquid Density	Over 0.65
Max Switching Capacity	220VAC 0.5A 110VDC 0.3A

(Detection point 1 - 3)

KSPB

Material : Stainless steel

Heat-proof Temperature
MAX.100°C



Process Connection	R1-1/4 304SS equiv
Float	Φ30*30 304SS
Stopper	304SS
Liquid Density	Over 0.75
Max Switching Capacity	AC50VA DC50W

(Detection point 1 - 5)

MULTI-POINT MEASUREMENT

Without Terminal box

KS3

Material : Stainless steel

Heat-proof Temperature
MAX.100°C



Process Connection	M12*P1.25 Screw 304SS
Float	Φ30*30 304SS
Stopper	304SS
Liquid Density	Over 0.75
Max Switching Capacity	AC50VA DC50W

(Detection point 1 - 5)

KV3

Material: PVC

Heat-proof Temperature
MAX.50°C



Process Connection	M20*P2.5 Screw PVC
Float	Φ44*25 PVC
Stopper	PVC
Liquid Density	Over 0.8
Max Switching Capacity	AC50VA DC50W

(Detection point 1 - 3)

KP3

Material: Polypropylene

Heat-proof Temperature
MAX.100°C



Process Connection	M14*P1.5 Screw PP
Float	Φ25*27 PP
Stopper	PTFE
Liquid Density	Over 0.75
Max Switching Capacity	AC50VA DC50W

(Detection point 1 - 3)

Line of business

- Rotary Paddle Type Level Switch
- Vibration Type Level Switch
- Swing Type Level Switch
- Acoustic Level Switch
- Capacitance Type Level Switch
- Capacitive Proximity Sensor
- Capacitance Type Level Indicator
- Diaphragm Type Level Switch
- Tilt Switch
- Leak Type Level Switch
- Microwave Switch
- Sounding Bob Type Level Indicator
- Flow Switch
- Conductance Type Level Switch
- Float Switch
- Float Type Level Indicator
- Ultrasonic Type Level Indicator
- Equipments For Conveyor Lines
- Dust Monitor System
- Zirconia Oxygen Analyzer
- Laser Type Level Indicator
- RADAR Type Level Indicator
- On-line Sensors for Accurate Liquid Analysis
- Ultrasonic Flow meter

*Please be sure to read USER'S GUIDE, Installation & Operation Instructions before using the instrument.

*The specifications herein may be subject to change without advance notice.

Nuclear Power Generation to Rice Milling
All-round Manufacturer of Level Controllers for Powder, Granules and Liquid

KANSAI Automation Co.,Ltd.

Headquarters :
2-14, Togano-cho, Kita-ku, Osaka 530-0056, Japan
TEL. 81-6-6312-2071 FAX. 81-6-6314-0848
e-mail: info@kansai-automation.co.jp

<http://www.kansai-automation.co.jp>

Tokyo Branch : 1-29-6, Hamamatsu-cho, Minato-ku, Tokyo 105-0013, Japan
TEL. 81-3-5777-6931 FAX. 81-3-5777-6933

Nagoya Office : 3-31-27, Uchiyama, Chigusa-ku, Nagoya 464-0075, Japan
TEL. 81-52-741-2432 FAX. 81-52-741-1588

Kyushu Office : 1-2-39, Asano, Kokura Kita-ku, Kitakyushu 802-0001, Japan
TEL. 81-93-511-4741 FAX. 81-93-511-4580



Design, development, and manufacture of level measuring sensors

Agent

SCIGATE
Your Automation Partner



SCIGATE AUTOMATION (S) PTE LTD

No.1 Bukit Batok Street 22 #01-01 Singapore 659592
Tel: (65) 6561 0488 Fax: (65) 6562 0588
Email: sales@scigate.com.sg Web: www.scigate.com.sg

Business Hours: Monday - Friday 8.30am - 6.15pm