



**EMERSON™**  
Industrial Automation



## *Installation Guide*

---

# ***Low Voltage DC***

---

Unidrive SP  
Digitax ST

Part Number: 0471-0060-02  
Issue Number: 2



[www.controltechniques.com](http://www.controltechniques.com)

## General Information

The manufacturer accepts no liability for any consequences resulting from inappropriate, negligent or incorrect installation or adjustment of the optional parameters of the equipment or from mismatching the variable speed drive with the motor.

The contents of this guide are believed to be correct at the time of printing. In the interests of commitment to a policy of continuous development and improvement, the manufacturer reserves the right to change the specification of the product or its performance, or the content of the guide without notice.

All rights reserved. No parts of this guide may be reproduced or transmitted in any form or by any means, electrical or mechanical including, photocopying, recording or by an information storage or retrieval system, without permission in writing from the publisher.

## Environmental Statement

Control Techniques is committed to minimising the environmental impacts of its manufacturing operations and of its products throughout their life cycle. To this end, we operate an Environmental Management System (EMS) which is certified to the International Standard ISO 14001. Further information on the EMS, our Environment Policy and other relevant information is available on request, or can be found at [www.greendrives.com](http://www.greendrives.com).

The electronic variable speed drives manufactured by Control Techniques have the potential to save energy and (through increased machine/process efficiency) reduce raw material consumption and scrap throughout their long working lifetime. In typical applications, these positive environmental effects far outweigh the negative impacts of product manufacture and end-of-life disposal.

Nevertheless, when the products eventually reach the end of their useful life, they must not be discarded but should instead be recycled by a specialist recycler of electronic equipment. Recyclers will find the products easy to dismantle into their major component parts for efficient recycling. Many parts snap together and can be separated without the use of tools, whilst other parts are secured with conventional fasteners. Virtually all parts of the product are suitable for recycling.

Product packaging is of good quality and can be re-used. Large products are packed in wooden crates, while smaller products come in strong cardboard cartons which themselves have a high-recycled fibre content. If not re-used, these containers can be recycled. Polythene, used on the protective film and bags from wrapping product, can be recycled in the same way. Control Techniques' packaging strategy prefers easily recyclable materials of low environmental impact, and regular reviews identify opportunities for improvement.

When preparing to recycle or dispose of any product or packaging, please observe local legislation and best practice.

## Software Statement

This Solutions Module (SM) is supplied with the latest software version. When retro-fitting to an existing system, all software versions should be verified to confirm the same functionality as Solutions Modules of the same type already present. This also applies to products returned from a Control Techniques Service Centre or Repair Centre. If there is any doubt please contact the supplier of the product.

The software version of the Solutions Module can be identified by looking at Pr **MM.02** and Pr **MM.51**, where **MM** is the relevant menu number for the Solutions Module slot being used.

See Pr **MM.02** and Pr **MM.51** description later in this manual for more information.

The software version takes the form of xx.yy.zz, where Pr **MM.02** displays xx.yy and Pr **MM.51** displays zz (e.g. for software version 01.01.00 Pr **MM.02** will display 1.01 and Pr **MM.51** will display 0).

## REACH legislation

EC Regulation 1907/2006 on the Registration, Evaluation, Authorisation and restriction of Chemicals (REACH) requires the supplier of an article to inform the recipient if it contains more than a specified proportion of any substance which is considered by the European Chemicals Agency (ECHA) to be a Substance of Very High Concern (SVHC) and is therefore listed by them as a candidate for compulsory authorisation.

For current information on how this requirement applies in relation to specific Control Techniques products, please approach your usual contact in the first instance. Control Techniques position statement can be viewed at:

<http://www.controltechniques.com/REACH>

---

# Contents

---

<b>1</b>	<b>Safety Information .....</b>	<b>4</b>
1.1	Warnings, cautions and notes .....	4
1.2	Electrical safety - general warning .....	4
1.3	System design and safety of personnel .....	4
1.4	Environmental limits .....	5
1.5	Fire protection .....	5
1.6	Compliance with regulations .....	5
1.7	Motor .....	6
1.8	Adjusting parameters .....	6
1.9	Electrical installation .....	6
<b>2</b>	<b>Introduction .....</b>	<b>7</b>
2.1	Advantages of Low Voltage DC operation .....	7
2.2	Principles of operation .....	7
2.3	Operating modes .....	8
2.4	Low Voltage DC speed limitation .....	8
<b>3</b>	<b>Product information .....</b>	<b>10</b>
3.1	Ratings .....	10
<b>4</b>	<b>System design .....</b>	<b>12</b>
4.1	Required connections for Low Voltage DC operation .....	12
4.2	Low Voltage DC power supply .....	12
4.3	Low Voltage DC supply types .....	13
4.4	External softstart resistor .....	13
4.5	Important considerations and information .....	14
4.6	System configurations .....	14
4.7	Power circuit control logic and sequencing .....	24
4.8	External soft start circuit control .....	27
4.9	Running the motor .....	29
<b>5</b>	<b>Component data .....</b>	<b>30</b>
5.1	Fusing .....	30
5.2	Discharge resistor and protection .....	33
5.3	Brake resistor .....	34
5.4	External soft start resistor .....	40
5.5	Blocking diode (D1) .....	42
5.6	Supply capacitor (C1) .....	42
5.7	Supplier websites .....	43

---

# 1 Safety Information

---

## 1.1 Warnings, cautions and notes



A **Warning** contains information, which is essential for avoiding a safety hazard.



A **Caution** contains information, which is necessary for avoiding a risk of damage to the product or other equipment.



A **Note** contains information, which helps to ensure correct operation of the product.

## 1.2 Electrical safety - general warning

The voltages used in the drive can cause severe electrical shock and/or burns, and could be lethal. Extreme care is necessary at all times when working with or adjacent to the drive.

Specific warnings are given at the relevant places in this User Guide.

## 1.3 System design and safety of personnel

The drive is intended as a component for professional incorporation into complete equipment or a system. If installed incorrectly, the drive may present a safety hazard.

The drive uses high voltages and currents, carries a high level of stored electrical energy, and is used to control equipment which can cause injury.

Close attention is required to the electrical installation and the system design to avoid hazards either in normal operation or in the event of equipment malfunction. System design, installation, start up and maintenance must be carried out by personnel who have the necessary training and experience. They must read this safety information and this User Guide carefully.

The STOP and SAFE TORQUE OFF functions of the drive do not isolate dangerous voltages from the output of the drive or from any external option unit. The supply must be disconnected by an approved electrical isolation device before gaining access to the electrical connections.

**With the sole exception of the SAFE TORQUE OFF function on Unidrive SP and Digitax ST, none of the drive functions must be used to ensure safety of personnel, i.e. they must not be used for safety-related functions.**



The SAFE TORQUE OFF function is only available as standard on the Unidrive SP and Digitax ST.

Careful consideration must be given to the functions of the drive which might result in a hazard, either through their intended behavior or through incorrect operation due to a fault. In any application where a malfunction of the drive or its control system could lead to or allow damage, loss or injury, a risk analysis must be carried out, and where necessary, further measures taken to reduce the risk - for example, an over-speed protection device in case of failure of the speed control, or a fail-safe mechanical brake in case of loss of motor braking.

The SAFE TORQUE OFF function has been approved by BGIA as meeting the requirements of the following standards, for the prevention of unexpected starting of the drive:

EN 61800-5-2:2007 SIL 3

EN ISO 13849-1:2006 PL e

EN 954-1:1997 Category 3

The SAFE TORQUE OFF function may be used in a safety-related application. The system designer is responsible for ensuring that the complete system is safe and designed correctly according to the relevant safety standards.

## 1.4 Environmental limits

Instructions in the *Unidrive SP User Guide* and *Digitax ST User Guide* regarding transport, storage, installation and use of the drive must be complied with, including the specified environmental limits. Drives must not be subjected to excessive physical force.

## 1.5 Access

Drive access must be restricted to authorized personnel only. Safety regulations which apply at the place of use must be complied with.

## 1.6 Fire protection

The drive enclosure is not classified as a fire enclosure. A separate fire enclosure must be provided. Refer to the *Fire Protection* section in the relevant drive User Guide for further information.

## 1.7 Compliance with regulations

The installer is responsible for complying with all relevant regulations, such as national wiring regulations, accident prevention regulations and electromagnetic compatibility (EMC) regulations. Particular attention must be given to the cross-sectional areas of conductors, the selection of fuses or other protection, and protective earth (ground) connections.

The *Unidrive SP User Guide* and *Digitax ST User Guide* contain instructions for achieving compliance with specific EMC standards.

Within the European Union, all machinery in which this product is used must comply with the following directives:

- 2006/42/EC: Safety of machinery.
- 2004/108/EC: Electromagnetic Compatibility.

## 1.8 Motor

Ensure the motor is installed in accordance with the manufacturer's recommendations and that the motor shaft is not exposed.

Standard squirrel cage induction motors are designed for single speed operation. If it is intended to use the capability of the drive to run a motor at speeds above its designed maximum, it is strongly recommended that the manufacturer is consulted first.

Low speeds may cause the motor to overheat because the cooling fan becomes less effective. The motor should be installed with a protection thermistor. If necessary, an electric forced vent fan should be used.

The values of the motor parameters set in the drive affect the protection of the motor. The default values in the drive should not be relied upon.

It is essential that the correct value is entered in the motor rated current parameter, Pr **5.07** (or Pr **0.46** in Unidrive SP and Digitax ST). This affects the thermal protection of the motor.

## 1.9 Adjusting parameters

Some parameters have a profound effect on the operation of the drive. They must not be altered without careful consideration of the impact on the controlled system. Measures must be taken to prevent unwanted changes due to error or tampering.

## 1.10 Electrical installation

### 1.10.1 Electric shock risk

The voltages present in the following locations can cause severe electric shock and may be lethal:

- AC supply cables and connections
- Output cables and connections
- Many internal parts of the drive, and external option units

Unless otherwise indicated, control terminals are single insulated and must not be touched.

### 1.10.2 Stored charge

The drive contains capacitors that remain charged to a potentially lethal voltage after the AC supply has been disconnected. If the drive has been energized, the AC supply must be isolated at least ten minutes before work may continue.

## 2 Introduction

Before reading this document it is assumed that the user has familiarized themselves with the *Unidrive SP User Guide* and the *Digitax ST Technical Data Guide*.

Any Unidrive SP or Digitax ST drive can be configured for Low Voltage DC (LVDC) operation, however there are differences in the electrical connections and operating voltage range depending on the frame size of the drive.

This installation guide covers the following:

- Principles and advantages of Low Voltage DC operation
- Safety information
- Detailed information on required external components
- System design
- Electrical Installation

### 2.1 Advantages of Low Voltage DC operation

Low Voltage DC operation is intended for motor operation in an emergency back-up situation following failure of the AC supply, for example in elevators, or to limit the motor speed of servo motors during commissioning of equipment, for example a robot cell.

Even though Low Voltage DC operation is intended for an emergency back-up situation, it is also possible to run the drive permanently in this mode. In the case where the Low Voltage DC power supply is in the form of a battery, the length of time that the drive will run is limited by the battery capacity.

### 2.2 Principles of operation

Both the Unidrive SP and Digitax ST drives operate from a 3-phase AC supply (200V, 400V etc.) or a DC supply of the equivalent rectified voltage. This provides power for all control circuits via the SMPS (Switch Mode Power Supply), and power for the motor via the inverter.

Instead of powering the drive from a 3-phase AC supply it is also possible to operate the Unidrive SP or Digitax ST drives from an external Low Voltage DC supply, the supply voltage is dependant on the drive frame size as detailed in Table 2-1.

Note that this method of drive operation will be referred to as Low Voltage DC (LVDC) operation through the remainder of this document.

**Table 2-1 Low Voltage DC operating range**

Drive	Continuous operating range of a drive supplied by low voltage DC (Vdc)
DST	48-72
SP0	48-72
SP1	48
SP2	48-72
SP3	48-72
SP4	48-96*
SP5	48-96
SP6	48-96
SPMA/D	48-96

\*Size 4 200V drives have a continuous Low Voltage DC range of 48V to 72V.

The values given in Table 2-1 above are for a typical battery supplied system, this includes charging of the battery.

If no regen energy is present it is possible to use slightly higher voltage levels.

The AC supply and DC supply must not be connected at the same time, seamless change-over from AC to DC or DC to AC is not possible. See section 4.7 *Power circuit control logic and sequencing* on page 24.

For Low Voltage DC operation, as well as the main Low Voltage DC supply the following external supplies are required.

- **For Unidrive SP and Digitax ST drives** a 24Vdc supply must be connected to the +24V external input on the control terminal block of the drive (see Chapter 4 *System design* ). This supplies the control circuitry and may be connected permanently.
- **For Unidrive SP4, SP5, SP6 and SPMA/D drives** a 24Vdc external supply needs to be connected to the 24V Low Voltage DC mode enable terminal of the drive. This supply should only be connected when in Low Voltage DC operation (this supply is in addition to the +24V external input).(see Chapter 4 *System design* on page 12).

## 2.3 Operating modes

Low Voltage DC operation can be used in any of the following modes:

1. Open loop mode
  - Open loop vector
  - Fixed V/F mode (V/Hz)
  - Quadratic V/F mode (V/Hz)
2. RFC mode
3. Closed loop vector
4. Servo

## 2.4 Low Voltage DC speed limitation

When set up for Low Voltage DC operation, the drive can provide rated torque to the motor at low speeds. The maximum speed that can be achieved whilst operating from this supply is dependent on the type of motor connected to the drive as described below.

### 2.4.1 Operation with an induction motor

When operating with an induction motor the drive will effectively start to field weaken at the point that the output voltage requirement (based on the programmed V/F) reaches the maximum that the DC bus voltage of the drive can support (about 34V based on a DC bus of 48V). e.g. The drive would begin to field weaken the motor at around 4Hz for a 50Hz 400V motor.

The drive may continue to rotate the motor up to base speed. However, even with no external load (just a bare motor shaft) the motor could stall due to the reduced torque available whilst so far into field weakening.

Be aware that reduced torque may be experienced in instances where the motor requires significant voltage to magnetize; the reasons for this are listed below.

- The external Low Voltage DC power supply has reached it's maximum supply voltage to the drive.
- The drive has reached the maximum allowable output voltage available in this mode of operation.



Low Voltage DC operation CANNOT be used to limit the speed of an induction motor.



WARNING

The drive can only provide rated torque at low speeds as described above. It is very important to consider this when operating with an overhauling load such as lift applications, even with the correct braking resistor selection, the drive may not be able to maintain control of the load if the drive goes into field weakening.

## 2.4.2 Operation with a servo motor



WARNING

When in Low Voltage DC operation the Unidrive SP or Digitax ST may NOT be able to limit the speed of a servo motor with an overhauling load.



WARNING

If a permanent magnet motor is made to rotate at a high enough speed by an external torque, the DC bus of the drive and its associated wiring could rise above the lower voltage DC operating level.

The speed of a servo motor is limited based on the  $K_e$  (voltage constant) value as shown in the example below: -

A Unidrive SP or Digitax ST with a Low Voltage DC supply of 48V running a 3000 rpm servo motor which has a  $K_e$  value of 98V/K rpm.

- Calculate rpm per Volt. **1000rpm / 98V = 10.2rpm per volt**
- Calculate drive output voltage.  
 **$48V / (\sqrt{2}) = 34V$**
- From the above calculations the motor speed will be limited to:  
 **$10.2 \times 34 = 347rpm$**

### NOTE

The calculation above gives an estimated value and does not take into account motor volt drops etc.

# 3 Product information

## 3.1 Ratings

### 3.1.1 Drive output current ratings

For drive output current ratings please refer to the appropriate drive user guide.

### 3.1.2 Low Voltage DC rating

On all but Unidrive SP size 1, the applied Low Voltage DC supply level is set by the user in Pr 6.46.

On Unidrive SP size 1 this value is not adjustable. The value set by the user will be within limits as detailed below.

The default setting is 48V for all the drive sizes. The over-voltage ('OV') trip threshold and braking IGBT turn on voltage are scaled from this value as follows:

- Brake IGBT turn on =  $1.325 \times \text{Pr 6.46 (V)}$
- Over-voltage trip =  $1.45 \times \text{Pr 6.46 (V)}$

**NOTE**

The maximum supply voltage is governed by the 'OV' trip level and brake turn-on level. The drive may be supplied with a greater voltage than the nominal continuous operating voltage, providing there is suitable headroom between the applied DC voltage and the brake IGBT turn on voltage and that Regen energy has been taken into account.

**Table 3-1 Low Voltage DC drive rating**

Drive	Under voltage trip level	Minimum start up voltage	Nominal continuous operating voltage (Pr 6.46)		Maximum braking IGBT turn on voltage (Pr 5.05)		Maximum over voltage trip threshold (Pr 5.05)		Required current rating of low voltage DC supply
			200V drive variant	400V/575V/690V drive variant	200V drive variant	400V/575V/690V drive variant	200V drive variant	400V/575V/690V drive variant	
			V	V	V	V	V	V	
DST	35	40	48 to 72	48 to 72	95	95	104	104	2 x drive output current (heavy duty current rating)
SP0	35	40	48 to 72	48 to 72	95	95	104	104	
SP1	35	40	48	48	63	63	69	69	
SP2	35	40	48 to 72	48 to 72	95	95	104	104	
SP3	35	40	48 to 72	48 to 72	95	95	104	104	
SP4	35	40	48 to 72	48 to 96	95	127	104	139	
SP5	35	40	N/A	48 to 96	N/A	127	N/A	139	
SP6	35	40	N/A	48 to 96	N/A	127	N/A	139	
SPMA	35	40	N/A	48 to 96	N/A	127	N/A	139	
SPMD	35	40	N/A	48 to 96	N/A	127	N/A	139	

Minimum and maximum voltage values include ripple and noise. Ripple and noise levels must not exceed 5%.

**Minimum start up voltage**

This is the minimum voltage that is required to initially start up the drive.

**Maximum braking IGBT turn on voltage**

This is the voltage level that the drive braking IGBT will turn on.

### Maximum over voltage trip threshold

This is the voltage level that the drive will trip 'OV' (over-voltage).

#### 3.1.3 Drive control 24V rating

The table below shows the specification of the control +24V external input terminal that the user supply should meet.

**Table 3-2 Drive control 24V rating**

Drive	Maximum continuous operating voltage V	Minimum continuous operating voltage V	Nominal continuous Operating voltage V	Minimum start up voltage V	Nominal current consumption mA
All	30	19.2	24	21.6	500

Minimum and maximum voltage values include ripple and noise. Ripple and noise levels must not exceed 5%.

#### 3.1.4 24V Low Voltage DC mode enable rating

Table 3-3 shows the specification of the 24V Low Voltage DC mode enable terminal that the user supply should meet.

**Table 3-3 Low voltage DC mode enable rating**

Drive	Maximum continuous operating voltage V	Minimum continuous operating voltage V	Nominal continuous operating voltage V	Nominal current consumption mA
DST	N/A			
SP0 to 3	N/A			
SP4 to 6	30	19.2	24	500
SPMA/D	30	19.2	24	500

Minimum and maximum voltage values include ripple and noise. Ripple and noise levels must not exceed 5%.

#### NOTE

A common supply can be used for the drive control external +24V input and 24V Low Voltage DC mode enable.

---

## 4 System design

---

### 4.1 Required connections for Low Voltage DC operation

Table 4-1 illustrates what connections and voltage supplies are required for Low Voltage DC operation.

**Table 4-1 Required connections for Low Voltage DC operation**

Drive	Control +24V external input	24V Low Voltage DC mode enable	Connection to 48V terminal	LVDC supply +DC/ -DC	External soft start resistor
DST	✓	x	✓	✓	x
SP0	✓	x	✓	✓	x
SP1	✓	x	✓	✓	x
SP2	✓	x	✓	✓	x
SP3	✓	x	✓	✓	x
SP4	✓	✓	x	✓	✓
SP5	✓	✓	x	✓	✓
SP6	✓	✓	x	✓	✓
SPMA	✓	✓	x	✓	✓
SPMD	✓	✓	x	✓	✓

### 4.2 Low Voltage DC power supply

The supply should meet the requirements set out in section 3.1.2 *Low Voltage DC rating* on page 10.

If the Low Voltage DC supply is in the form of a battery and the voltage drops below 36V a UV trip will occur. A UV trip automatically resets if the DC bus is back within specification, which means it is possible for the drive to cycle in and out of the trip state if the drop in voltage only occurs under load.

I.e. The drive is in the 'rdy' condition and the DC bus is within specification. The drive is given the run command, which enables the output causing current to flow. The DC bus drops and a UV trip is seen, the drive output is thus disabled. The DC bus then rises back to the previous level and the UV trip resets. If the run command is still present the drive output is enabled, which causes current to flow etc.

One of the following should be implemented to prevent this loop from occurring:

1. SM-Applications module not used: A threshold from Menu 12 should be used to monitor the DC bus and trip the drive should it drop below normal operating levels with a charged battery.
2. SM-Applications module used: A software trap should be added to prevent this loop from occurring.

## 4.3 Low Voltage DC supply types

The DC supply may be connected to ground or left floating. In the event of a contactor sticking, high voltage would be present at the negative terminal of the drive.

The instructions below ensure user safety in both cases.

### 4.3.1 Systems with an isolated DC supply

The supply can be floating with respect to ground, although it may have a high impedance ground to drain leakage currents.

In the event of a fault where AC and DC supplies are connected at the same time a high current would have no fault path to ground.

In this case:

- The 48V, +DC, -DC terminals of the drive and DC terminals of the Low Voltage DC source must be protected from user contact.
- The Low Voltage DC supply must be able to withstand mains potential with respect to ground and be suitable for use in an industrial environment (category 2 supply).
- Cables rated for the voltage of the rectified 3-phase AC supply must be used to connect the drive to the Low Voltage DC supply.



In the event of a fault, the 48V, +DC, -DC terminals of the drive and DC terminals of the Low Voltage DC source (including any wiring in between) could be at a potentially lethal voltage.

### 4.3.2 Systems with a grounded DC supply



#### Electrochemical corrosion of earthing terminals

Ensure that grounding terminals are protected against corrosion i.e. as could be caused by condensation.



If the  $I^2t$  of the ground connection is not greater than that of the fuses used, then the 48V/DC terminal and associated wiring could be at a potentially lethal voltage in the event of a fault.

The ground connection for the supply must be a high current connection with an  $I^2t$  rating greater than the fuses F2a & F2b (see section 5.1 *Fusing* on page 30).

This is so that in the event of a fault where AC and DC supplies are connected at the same time, a high current will flow to ground and blow the fuses in the Low Voltage DC path.

- The wiring from the drive to fuses F2a, F2b & F2c must be protected to a voltage rating equal to or exceeding the rectified 3-phase AC supply voltage (see section 5.1 *Fusing* on page 30).
- The wiring from the fuse to the supply must be rated correctly for the supply.

## 4.4 External softstart resistor

When Unidrive SP size 0 to 3 or Digitax ST operates from AC or DC, there is an inbuilt soft start resistor to limit the inrush current. However when Unidrive SP size 4 and larger operate from Low Voltage DC there is no inbuilt soft start resistor and therefore an external soft start resistor is required between the Low Voltage DC supply and the drive.

#### NOTE

Failure to fit a soft start resistor may damage the drive or/and external components.

## 4.5 Important considerations and information

- It is possible to run the drive permanently in Low Voltage DC operation.
- The AC supply and DC supply must not be connected at the same time, seamless change-over from AC to DC or DC to AC is not possible.
- The drive must be disabled during change over of supplies.
- The DC bus must be forcibly discharged to less than the low voltage braking IGBT turn on level or less when changing from one supply to another to ensure that the pre-charge circuits operate correctly. If the load motor is a permanent magnet type, steps must be taken to ensure that it is stationary or rotating slowly enough that the emf induced in the windings is less than 25V r.m.s.
- To achieve a reasonably short discharge time an external discharge resistor is normally required.
- Software should not be used to interlock the supplies, discharge resistor and drive enable. A software failure could result in hardware damage. Software may however be used for time delays and selection logic
- All thermal overload devices used must be connected to the supply selection interlocks, removing AC and DC supplies in the event of a device tripping.
- For Low Voltage DC operation under AC supply loss conditions; all relays and contactors must be driven from a maintained supply.
- The system design must adhere to one of the system configurations discussed in section 4.6 *System configurations* on page 14.
- Pr **6.44** indicates which supply the drive is currently operating from:
  - 0 = Normal high voltage supply
  - 1 = Low Voltage DC supply.

## 4.6 System configurations

The following diagrams show different system configurations for a Unidrive SP or Digitax ST operating from a Low Voltage DC supply.

The choice of system configuration depends on the amount of regen energy the DC supply can absorb.

### 4.6.1 System configuration 1

This system configuration is suitable for systems where the power supply cannot absorb any energy from the load through the drive, hence the reason for blocking diode D1 being installed in series with the DC supply.



**Table 4-2 Key for Figure 4-1**

Key	Description
Aux.1	Ovld.1 auxiliary contact
C1	DC supply capacitor (SP1 only)
D1	Blocking diode to prevent energy from being returned to the LVDC supply
Ovld.1	Thermal overload relay to protect the discharge resistor
F1a	3 phase AC supply fusing
F2a	Fuse for LVDC supply feed to drive +DC terminal
F2b	Fuse for LVDC supply feed to drive -DC terminal
F2c	Fuse for LVDC supply feed to drive 48V terminal
F3	Fuse for drive control 24V external input
K1	Normally open contacts supplying the drive with 3 phase AC when energized
K1b	Normally closed contacts that bring in the discharge resistor when the AC supply is removed
K2a	Normally open contact, which when closed supplies the drive with the positive feed from the LVDC power supply
K2b	Normally open contact, which when closed supplies the drive with the negative feed from the LVDC power supply
K2c	Normally open contacts which when closed supply the 48V terminal of the drive with LVDC
K2d	Normally closed contacts that bring in the discharge resistor when the DC supply is removed
PS1	LVDC power supply
Rdis	DC bus discharge resistor

**4.6.2 Control implementation for system configuration 1**

In order to achieve the required Low Voltage DC operation sequencing as detailed in section 4.7 *Power circuit control logic and sequencing* on page 24. The circuitry shown in Figure 4-1 and Figure 4-2 below is required.

Some of the circuitry shown in Figure 4-2 can be reduced by using SM-Applications, this is further discussed in section 4.7.2 *Control implementation using SM-Applications* on page 26.

**Figure 4-2 Control circuitry for system configuration 1**

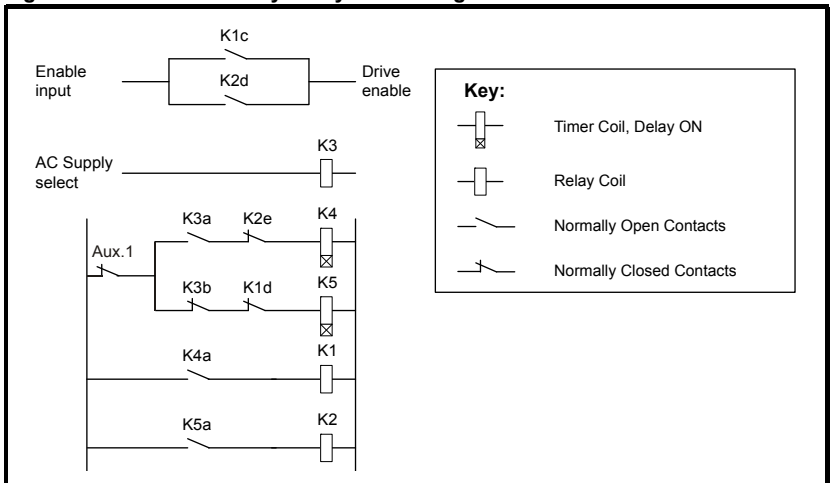



**Table 4-3 Key for Figure 4-3**

Key	Description
Aux.1	Ovld.1 auxiliary contact
D1	Blocking diode to prevent energy from being returned to the LVDC supply
Ovld.1	Thermal overload relay to protect the discharge resistor
F1a	3 phase AC supply fusing
F2a	Fuse for LVDC supply feed to drive +DC terminal
F2b	Fuse for LVDC supply feed to drive -DC terminal
F2d	Fuse for 24V LVDC mode enable input.
F3	Fuse for drive control 24V external input
F4	Fuse to protect Rs
K1	Normally open contacts supplying the drive with 3 phase AC when energized
K1b	Normally closed contacts that bring in the discharge resistor when the AC supply is removed
K2a	Normally open contact, which when closed supplies the drive with the positive feed from the LVDC power supply
K2b	Normally open contact, which when closed supplies the drive with the negative feed from the LVDC power supply
K2d	Normally closed contacts that bring in the discharge resistor when the DC supply is removed
K2g	Normally closed contacts supplying the 24V LVDC mode enable terminal
PS1	LVDC power supply
Rly1	Soft start relay that brings the soft start resistor in/out of the DC supply circuit
Rdis	DC bus discharge resistor
Rs	External soft start resistor

#### 4.6.3 Control implementation for system configuration 1

In order to achieve the required Low Voltage DC operation sequencing as detailed in section 4.7 *Power circuit control logic and sequencing* on page 24, the circuitry shown in Figure 4-3 and Figure 4-4 is required.

Some of the circuitry shown in Figure 4-4 can be reduced by using SM-Applications, this is further discussed in section 4.7.2 *Control implementation using SM-Applications* on page 26.

**Figure 4-4 Control relays for system configuration 1**

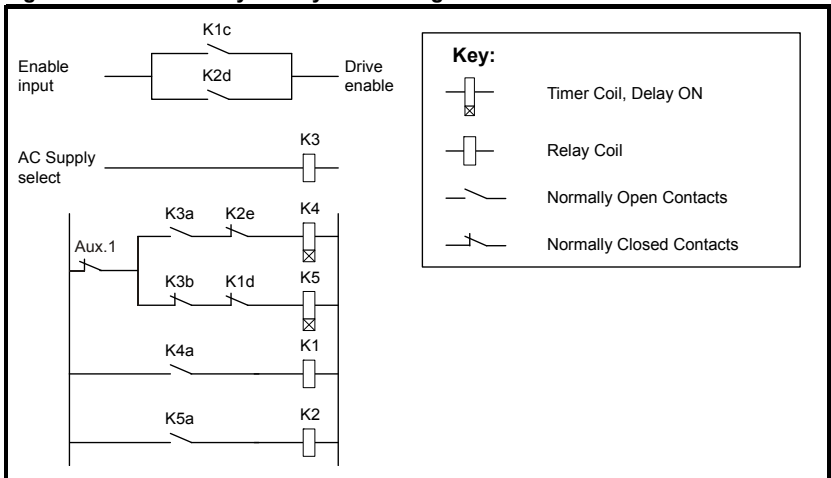

#### 4.6.4 Preventing over-voltage trips from occurring without the use of a brake resistor

In the above systems, in the case where the load is transferring energy back to the drive through the motor, the DC bus voltage will rise. If the Low Voltage DC supply is unable to absorb this energy, the DC bus voltage will continue to rise until the drive trips out on over-voltage ('OV'). The drive over-voltage level is dependant on the drive frame size (See section 3.1.2 *Low Voltage DC rating* on page 10 for details).

Below are recommendations for preventing this from happening:

1. Lower the setting of the regen current limit (Pr **4.06**). This limits how much energy the drive will absorb from the load.



**WARNING**

Reducing the regen current limit can result in the drive losing control of the load under overhauling load conditions.

2. Ensure that the drive is operating in one of the Standard ramp modes (Pr **2.04**) and lower the setting of the Standard ramp voltage (Pr **2.08**) to 65.

The changing of the Standard ramp voltage can be automated by the use of the variable select function, (Menu 12) and the programmable logic function, (Menu 9).

**NOTE**

If the above recommendations are unsuccessful and the drive still trips on over-voltage ('OV'), then it is likely that the regen energy is significant enough to require a braking resistor. If this is the case refer to section 4.6.5 *System configuration 2* on page 20.

## 4.6.5 System configuration 2

This configuration is suitable for systems where the drive may be expected to absorb energy from the load at drive rated current (including overload current if applicable), and dissipate this energy into a brake resistor. However, further consideration is required when using a brake resistor in Low Voltage DC mode.

As the DC bus voltage varies the motor power available varies in proportion to the voltage but the power that may be dissipated in a brake resistor varies with the square of the voltage. To enable the maximum brake power to match that from the motor in Low Voltage DC mode, the brake resistor value must be reduced in proportion to the voltage. The arrangement shown in the circuit below automatically connects the appropriate brake resistor depending on the supply voltage. Note that the brake resistor thermal overload devices are also connected to the supply selection interlocks. If either resistor overheats, then the Low Voltage DC and AC supplies are both tripped off. As shown in Figure 4-6 *Control circuitry for system configuration 2* on page 21.

**Figure 4-5 System configuration 2 circuit diagram for Unidrive SP size 0 to 3**

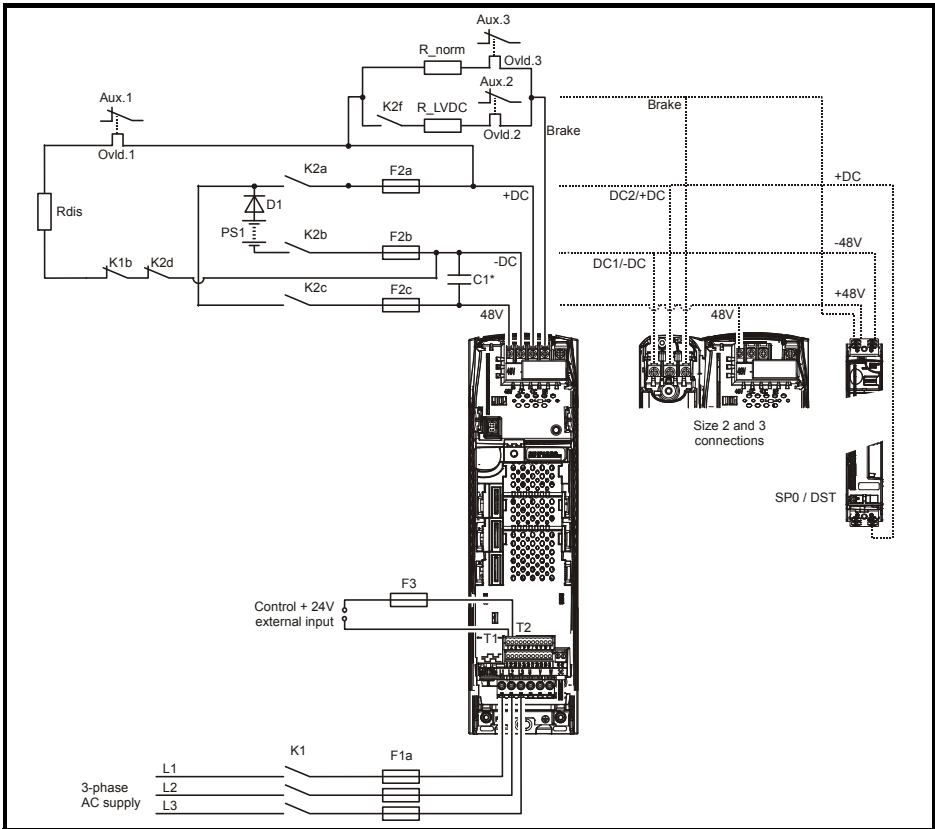

\*C1 is only required with Unidrive SP size 1

**NOTE** The total brake resistance used in Low Voltage DC mode is the parallel configuration of R\_ LVDC and R\_norm.

See Chapter 5 *Component data* on page 30 for details on components.

**Table 4-4 Key for Figure 4-5**

Key	Description
Aux.1	Ovld.1 auxiliary contact
Aux.2	Ovld.2 auxiliary contact
Aux.3	Ovld.3 auxiliary contact
Ovld.3	Thermal overload relay for high voltage braking resistor
Ovld.2	Thermal overload relay for low voltage braking resistor
C1	DC supply capacitor (SP1 only)
D1	Blocking diode to prevent energy from being returned to the LVDC supply
Ovld.1	Thermal overload relay to protect the discharge resistor
F1a	3 phase AC supply fusing
F2a	Fuse for LVDC supply feed to drive +DC terminal
F2b	Fuse for LVDC supply feed to drive -DC terminal
F2c	Fuse for LVDC supply feed to drive 48v terminal
F3	Fuse for drive control 24V external input
K1	Normally open contacts supplying the drive with 3 phase AC when energized
K1b	Normally closed contacts that bring in the discharge resistor when the AC supply is removed
K2a	Normally open contact, which when closed supplies the drive with the positive feed from the LVDC power supply
K2b	Normally open contact, which when closed supplies the drive with the negative feed from the LVDC power supply
K2c	Normally open contacts which when closed supply the 48V terminal of the drive with LVDC
K2d	Normally closed contacts that bring in the discharge resistor when the DC supply is removed
K2f	Normally open contacts which when closed bring R_LVDC into circuit
PS1	LVDC power supply
Rdis	DC bus discharge resistor
R_LVDC	Low voltage braking resistor
R_norm	High voltage braking resistor

**4.6.6 Control implementation for system configuration 2**

In order to achieve the required Low Voltage DC operation sequencing as detailed in section 4.7 *Power circuit control logic and sequencing* on page 24. The circuitry shown in Figure 4-5 and Figure 4-6 is required.

Some of the circuitry shown in Figure 4-6 can be reduced by using SM-Applications, this is further discussed in section 4.7.2 *Control implementation using SM-Applications* on page 26.

**Figure 4-6 Control circuitry for system configuration 2**

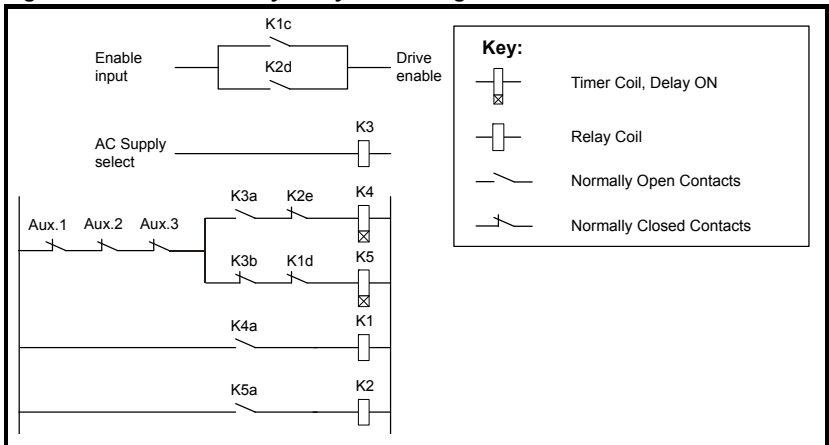

**Figure 4-7 System configuration 2 circuit diagram for Unidrive SP size 4 to 6, SPMA/D**

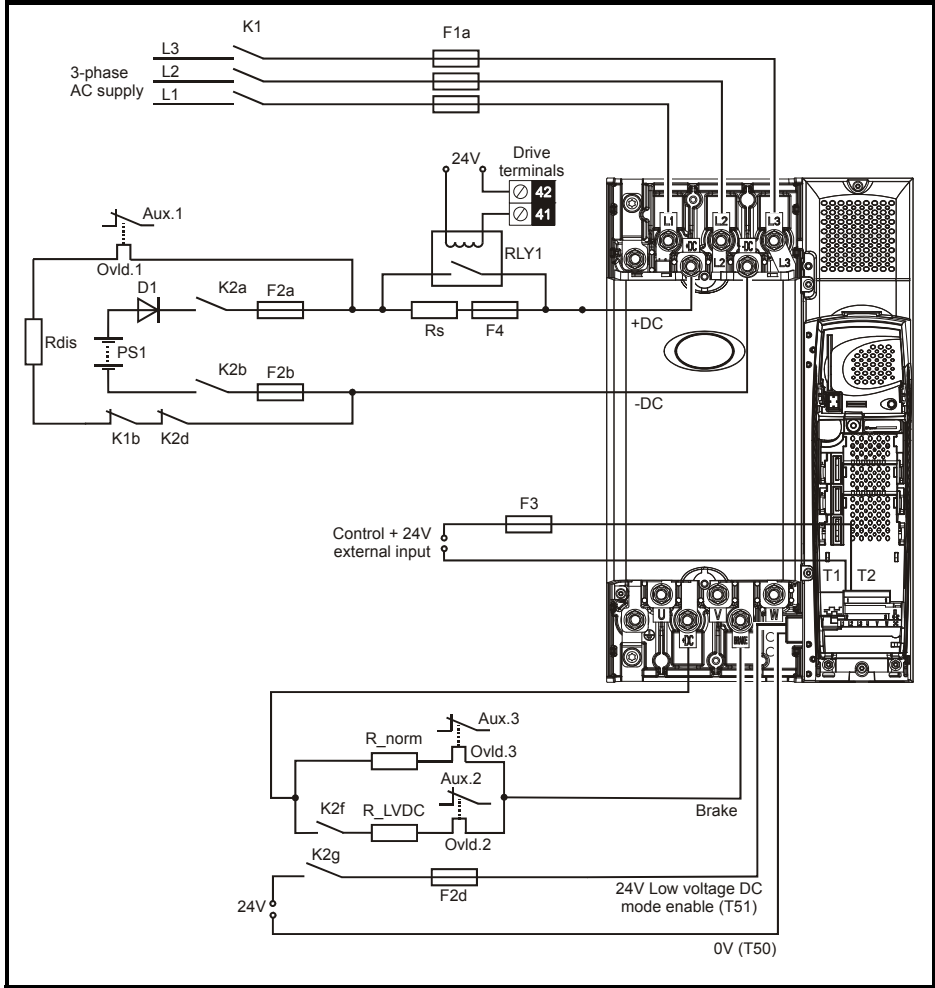

**NOTE** The total brake resistance used in Low Voltage DC mode is the parallel configuration of R<sub>LVDC</sub> and R<sub>norm</sub>.

See Chapter 5 *Component data* on page 30 for details on components.

See section 4.8 *External soft start circuit control* on page 27 for external soft start circuit control.

**Table 4-5 Key for Figure 4-7**

Key	Description
Aux.1	Ovld.1 auxiliary contact
Aux.2	Ovld.2 auxiliary contact
Aux.3	Ovld.3 auxiliary contact
Ovld.3	Thermal overload relay for high voltage braking resistor
Ovld.2	Thermal overload relay for low voltage braking resistor
D1	Blocking diode to prevent energy from being returned to the LVDC supply
Ovld.1	Thermal overload relay to protect the discharge resistor
F1a	3 phase AC supply fusing
F2a	Fuse for LVDC supply feed to drive +DC terminal
F2b	Fuse for LVDC supply feed to drive -DC terminal
F2d	Fuse for LVDC mode enable input.
F3	Fuse for drive control 24V external input
K1	Normally open contacts supplying the drive with 3 phase AC when energized
K1b	Normally closed contacts that bring in the discharge resistor when the AC supply is removed
K2a	Normally open contact, which when closed supplies the drive with the positive feed from the LVDC power supply
K2b	Normally open contact, which when closed supplies the drive with the negative feed from the LVDC power supply
K2d	Normally closed contacts that bring in the discharge resistor when the DC supply is removed
K2f	Normally open contacts which when closed bring R_LVDC into circuit
K2g	Normally closed contacts supplying the LVDC mode enable terminal
PS1	LVDC power supply
Rly1	Softstart relay that brings the softstart resistor in/out of the DC supply circuit
Rdis	DC bus discharge resistor
Rs	External softstart resistor
R_LVDC	Low voltage braking resistor
R_norm	High voltage braking resistor

**4.6.7 Control implementation for system configuration 2**

In order to achieve the required Low Voltage DC operation sequencing as detailed in section 4.7 *Power circuit control logic and sequencing* on page 24. The circuitry shown in Figure 4-7 and Figure 4-8 is required.

Some of the circuitry shown in Figure 4-8 can be reduced by using SM-Applications, this is further discussed in section 4.7.2 *Control implementation using SM-Applications* on page 26.

**Figure 4-8 Control relays for system configuration 2**

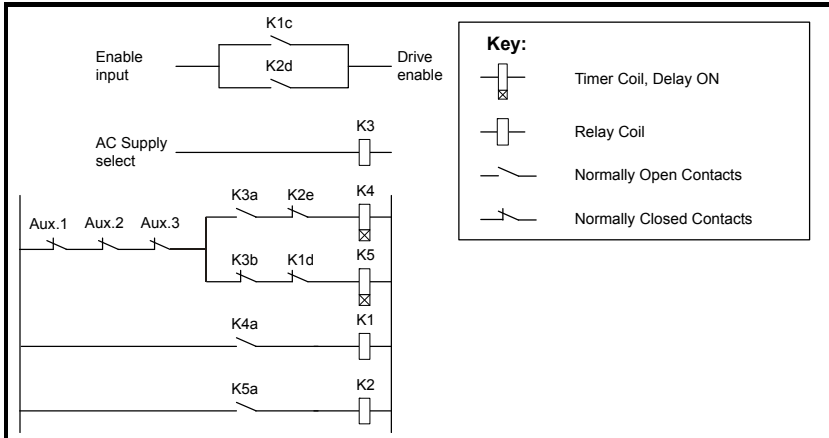

## 4.7 Power circuit control logic and sequencing

Control logic is required to interlock and sequence the contactors set out in section 4.6 *System configurations* on page 14 to ensure correct operation. This can be accomplished using relays and timers or an SM-Applications Solutions Module.

Figure 4-9 shows the basic logic that is required. The logic provides the following functions:

- Change-over delay.
- Prevention of both supplies being connected to the drive at the same time.
- The discharge contactor is closed when neither supply is connected.
- Automatic change over of the supply if the AC supply fails, or change-over by switch selection.
- The drive is disabled when neither supply is connected.

**Figure 4-9 Control logic diagram**

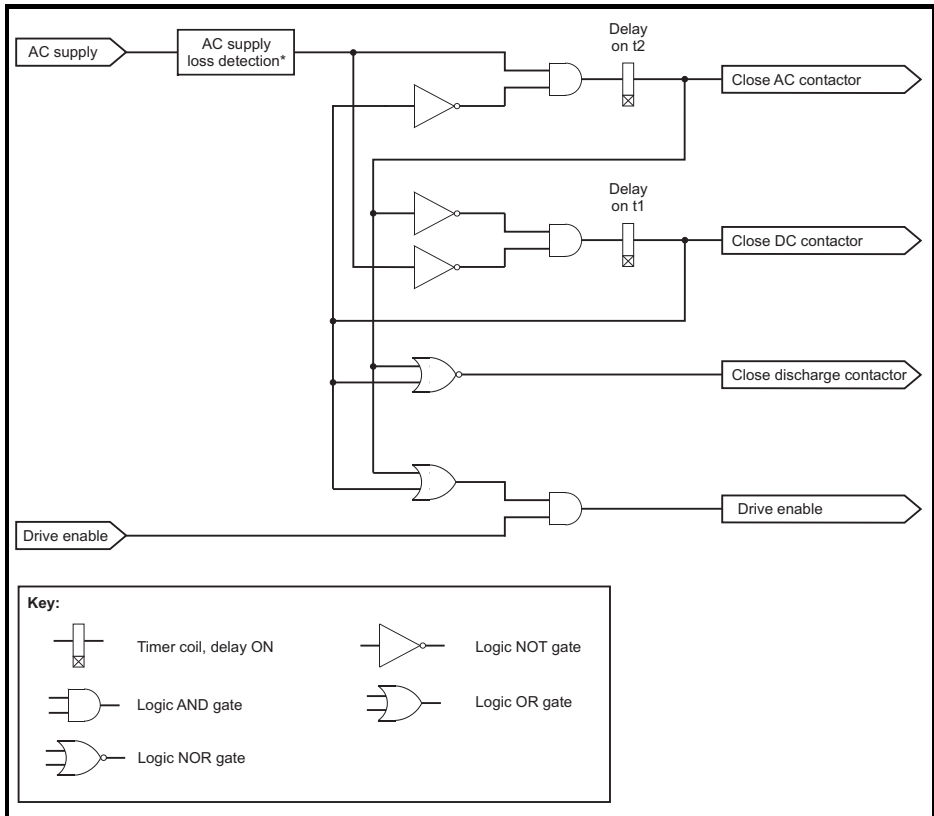

\*Supply loss detection signal could also be the output of a supply selector switch (Low Voltage DC or nominal AC supply).

## 4.7.1 Control logic sequencing

Figure 4-10 shows the sequencing of the signals which must be accomplished with this logic.

**Figure 4-10 Control logic and sequencing**

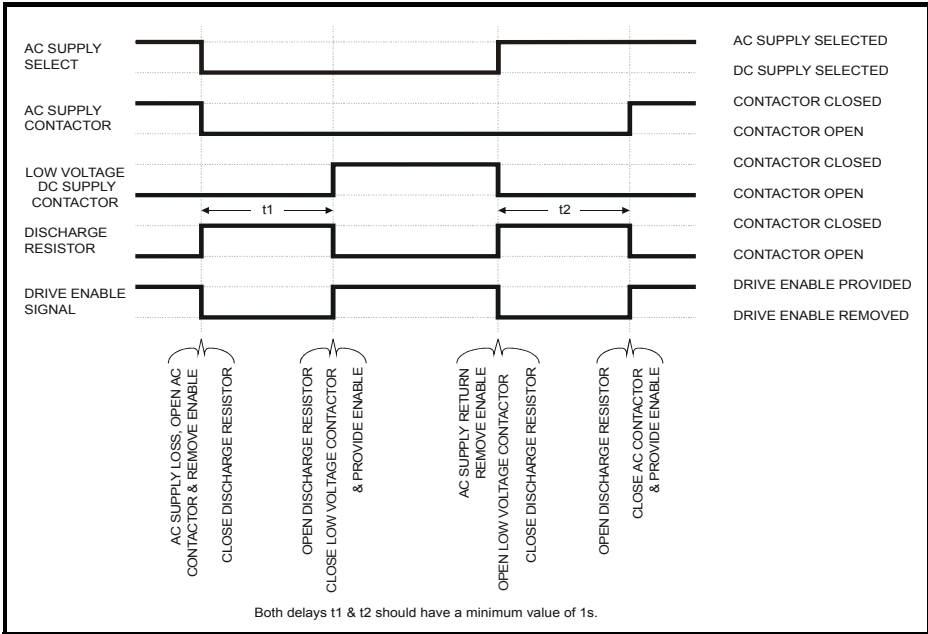

### 4.7.2 Control implementation using SM-Applications

Using a second processor simplifies some of the external circuits that are required as some of the logic and timing can be implemented in software, for example as DPL code. To use this option for automatic change-over of supplies under mains loss conditions, the control circuits must be fed from a maintained supply so that when AC power fails the control circuits stay live.

This circuit below uses the control board and second processor to control the power contactors K1 & K2. AC/Low Voltage DC supply selection relay K3 (not shown) provides a supply status signal to the processor. The software then provides time delays and some interlocks. Note that hardware interlocks are used for supply switching and drive enable. Software should not be used for the interlocks as a software fault could result in hardware damage.

**Figure 4-11 Control relays with SM-Applications**

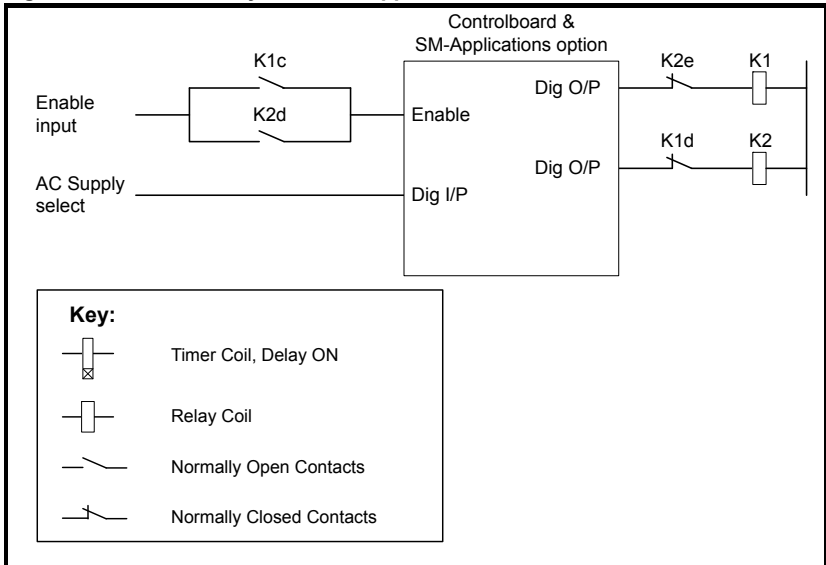

### 4.7.3 Sequencing for the SM-Applications option module

**Figure 4-12 Sequencing for the SM-Applications Solutions Module**

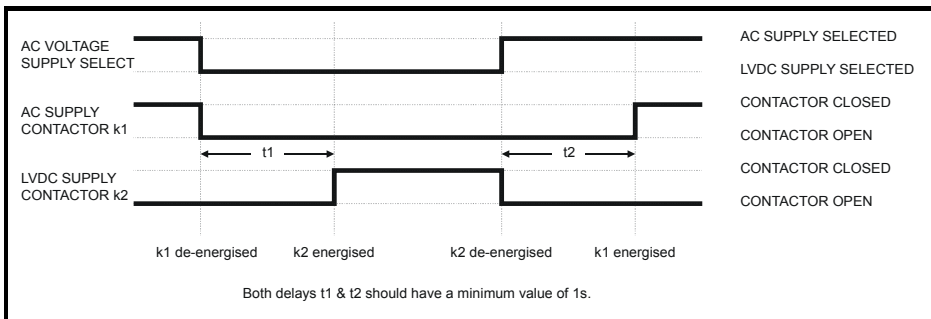

The SM-Applications program should be based on the above sequencing, controlling two of the drive's digital outputs depending on the state of the AC supply select digital input.

## 4.8 External soft start circuit control

As discussed in section 4.4 *External softstart resistor* on page 13 an external soft start resistor is required for Unidrive SP size 4 and larger.

The soft start resistor only needs to be in circuit at certain times as shown in the flow diagram below.

**Figure 4-13 Soft start control circuit sequencing**

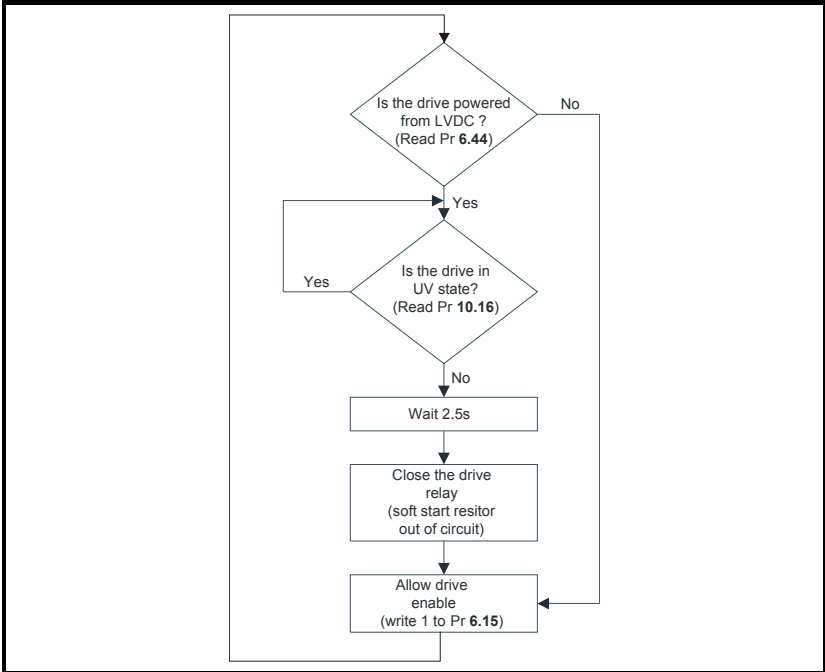

The above sequencing can be achieved using the drive internal function blocks as shown in Figure 4-14 on page 28.

**Figure 4-14 Soft start control circuit using drive internal logic**

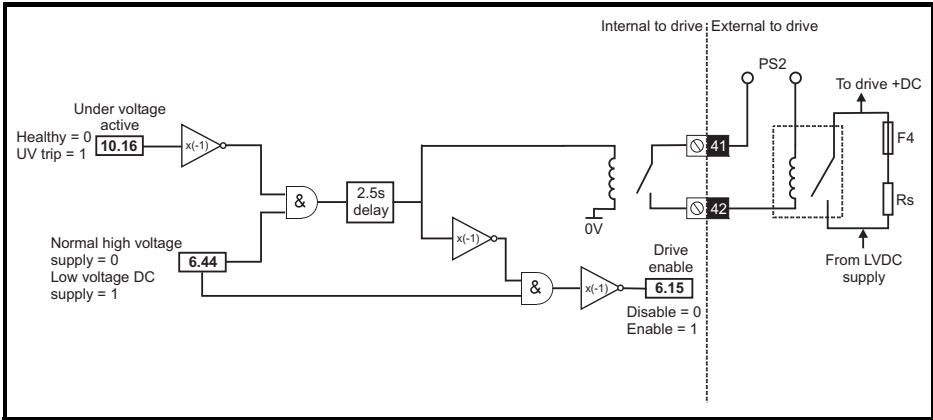

**Table 4-6 Parameter set up required for Figure 4-14**

Parameter	Default value	Value to be entered	
Pr 9.04	Function 1 input 1 source parameter	0.00	10.16
Pr 9.05	Function 1 input 1 invert	OFF (0)	On (1)
Pr 9.06	Function 1 input 2 source parameter	0.00	6.44
Pr 9.09	Function 1 delay	0.0	2.5
Pr 8.27	Drive relay source	10.01	9.01
Pr 9.14	Function 2 input 1 source parameter	0.00	9.01
Pr 9.15	Function 2 input 1 invert	OFF (0)	On (1)
Pr 9.16	Function 2 input 2 source parameter	0.00	6.44
Pr 9.18	Function 2 output invert	OFF (0)	On (1)
Pr 9.20	Function 2 destination parameter	0.00	6.15

The soft start control circuit provides the following functions:

- Opens and closes the external soft start relay contacts, which brings the external soft start resistor in and out of circuit.
- Prevents the drive from running whilst the soft start resistor is in circuit (when in Low Voltage DC mode only).
- Ensures that the drive DC bus has reached a voltage level in which the soft start resistor can be taken out of circuit.

**Figure 4-15 Logic function diagram**

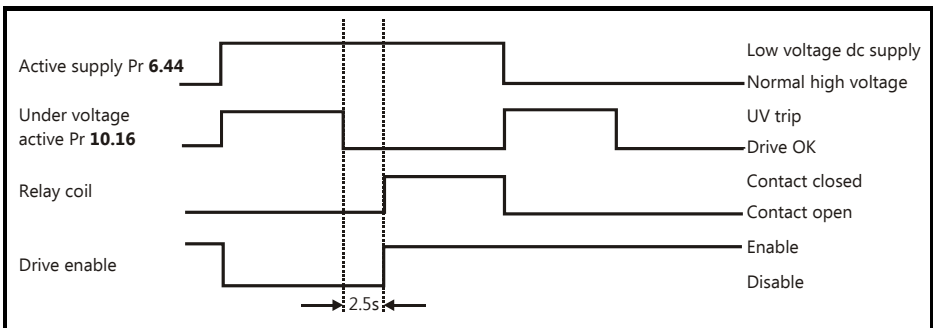

## 4.9 Running the motor

For information on tuning of the drive for best performance please refer to the Running the motor and optimization section of the *Unidrive SP User Guide*.



Ensure that no damage or safety hazard could arise from the motor starting unexpectedly.



The values of the motor parameters affect the protection of the motor. The default values in the drive should not be relied upon. It is essential that the correct value is entered in Pr **0.46 Motor rated current**. This affects the thermal protection of the motor.



If the keypad mode has been used previously, ensure that the keypad reference has been set to 0 using the  buttons as if the drive is started using the keypad it will run to the speed defined by the keypad reference (Pr **0.35**).



If the intended maximum speed affects the safety of the machinery, additional independent over-speed protection must be used.

### 4.9.1 Autotuning

In order for the drive to obtain the correct motor parameter values, the autotune should be carried out when operating from a normal high voltage supply and not when in Low Voltage DC operation. If it is not possible to autotune the drive when operating from a normal high voltage supply the motor parameters should be obtained from the motor nameplate and entered into the drive manually.

# 5 Component data

## 5.1 Fusing

**Table 5-1 Recommended Low Voltage DC supply fuse current ratings (Unidrive SP size 1 to 3)**

The fuse voltage rating must be suitable for the rectified drive AC supply voltage e.g. $\geq 400\text{Vdc}$ for a SPX20X, and DST120X $\geq 750\text{Vdc}$ for a SPX40X and DST140X $\geq 890\text{Vdc}$ for a SPX50X, and $\geq 1000\text{Vdc}$ for a SPX60X				
Drive	USA CC fast acting fuse F2a & F2b (A)	European gl-gG fuse F2a & F2b (A)	F2c (A)	F3 (A)
DST1201*	7	6	1	3A 50Vdc
DST1202*	12	10		
DST1203*	20	16		
DST1204*	25	25		
SP0201	4	4	1	3A 50Vdc
SP0202	6	6		
SP0203	7	8		
SP0204	10	10		
SP0205	15	16		
DST1401	4	4	1	3A 50Vdc
DST1402	7	6		
DST1403	10	10		
DST1404	15	16		
DST1405	20	20		
SP0401	2	2	1	3A 50Vdc
SP0402	3	4		
SP0403	4	4		
SP0404	6	6		
SP0405	7	8		
SP1201	7	8	1	3A 50Vdc
SP1202	10	10		
SP1203	15	16		
SP1204	20	20		
SP2201	25	25	1	3A 50Vdc
SP2202	32	35		
SP2203	45	50		
SP3201	60	63	1	3A 50Vdc
SP3202	90	100		
SP1401	3	4	1	3A 50Vdc
SP1402	6	6		
SP1403	7	8		
SP1404	10	10		
SP1405	15	16		
SP1406	20	20		

The fuse voltage rating must be suitable for the rectified drive AC supply voltage e.g. $\geq 400\text{Vdc}$ for a SPX20X, and DST120X $\geq 750\text{Vdc}$ for a SPX40X and DST140X $\geq 890\text{Vdc}$ for a SPX50X, and $\geq 1000\text{Vdc}$ for a SPX60X				
Drive	USA CC fast acting fuse F2a & F2b (A)	European gl-gG fuse F2a & F2b (A)	F2c (A)	F3 (A)
SP2401	25	25	1	3A 50Vdc
SP2402	32	35		
SP2403	45	50		
SP2404	60	63		
SP3401	60	63	1	3A 50Vdc
SP3402	80	80		
SP3403	90	100		
SP3501	7	8	1	3A 50Vdc
SP3502	10	10		
SP3503	15	16		
SP3504	16	20		
SP3505	25	25		
SP3506	32	35		
SP3507	45	50		

\* For Digitax ST, the fuse ratings are for the default value of motor thermal protection time constant. If the thermal time constant value is increased, then the maximum current can flow for a longer time so the fuse rating would have to be re-calculated.

**Table 5-2 Recommended Low Voltage DC supply fuse current ratings (Unidrive SP size 4 to 6, SPMA/D)**

Drive	The fuse voltage rating must be suitable for the rectified drive AC supply voltage, e.g. $\geq 400\text{Vdc}$ for a SPX20X, $\geq 750\text{Vdc}$ for a SPX40X, $\geq 890\text{Vdc}$ for a SPX50X, and $\geq 1000\text{Vdc}$ for a SPX60X			F2d	F3
	USA fuse F2a & F2b	European fuse F2a & F2b	F2c		
	(A)	(A)	(A)		
SP4201	110	125	1	8A 600V AC fast acting class CC type fuse	3A 50Vdc
SP4202	150	160			
SP4203	160	175			
SP4401	125	125			
SP4402	150	160			
SP4403	175	200			
SP5401	225	250			
SP5402	300	315			
SP6401	350	350			
SP6402	450	450			
SPMA1401	350	350			
SPMA1402	450	450			
SPMD1401	350	350			
SPMD1402	450	450			
SPMD1403	500	500			
SPMD1404	600	630			
SP4601	35	40			
SP4602	45	50			
SP4603	50	50			
SP4604	70	80			
SP4605	90	100			
SP4606	100	100			
SP5601	125	125			
SP5602	175	200			
SP6601	200	200			
SP6602	250	250			
SPMA1601	200	200			
SPMA1602	250	250			
SPMD1601	200	200			
SPMD1602	250	250			
SPMD1603	300	300			
SPMD1604	350	355			

## 5.2 Discharge resistor and protection

The discharge resistor is required to discharge the DC bus of the drive whilst changing from one supply to the other.

**Table 5-3 Discharge resistor and protection values**

Drive	Rdis (Ω)	Total Power rating (W)	Short term (1s) energy rating (J)	Thermal overload relay trip setting (A)*
DST1201	680	17	12180	0.1
DST1202 to DST1203	220	9	6660	0.13
DST1204	100	19	14040	0.28
SP0201	680	17	12180	0.1
SP0202 to SP0204	220	9	6660	0.13
SP0205	100	19	14040	0.28
SP1201 to SP1202	220	6	3950	0.13
SP1203 to SP1204	100	4	2580	0.25
SP2201 to SP2203	100	6	4030	0.34
SP3201 to SP3202	100	12	8670	0.48
SP4201 to SP4203	100	9	6470	0.48
DST1401 to DST1405	680	17	12180	0.1
SP0401 to SP0405	680	17	12180	0.1
SP1401 to SP1406	680	17	12180	0.1
SP2401 to SP2404	220	6	3940	0.25
SP3401 to SP3403	220	11	7720	0.32
SP4401	220	9	6660	0.3
SP4402 to SP4403	100	18	13050	0.6
SP5401 to SP5402	100	25	18330	0.79
SP6401	100	33	24510	1.0
SP6402	100	49	36250	1.1
SPMA1401	100	33	24510	1.0
SPMA1402	100	49	36250	1.1
SPMD1401	100	33	24510	1.0
SPMD1402	100	49	36250	1.1
SPMD1403 to SPMD1404	100	62	46560	1.1
SP3501 to SP3507	220	12	8870	0.35
SP5601 to SP5602	100	23	17210	0.8
SP6601 to SP6602	100	35	25850	0.9
SPMA1601	100	35	25850	0.9
SPMA1602	100	35	25850	0.9
SPMD1601	100	35	25850	0.9
SPMD1602	100	35	25850	0.9
SPMD1603	100	37	27230	1.0
SPMD1604	100	37	27230	1.1

\* The chosen thermal overload relay must have a class 10 trip characteristic.



### High temperatures

The discharge resistor can reach high temperatures. Locate the resistors so that damage cannot result. Use cable having insulation capable of withstanding high temperatures.

## 5.3 Brake resistor

As the DC bus voltage varies the motor power available varies in proportion to the voltage but the power that may be dissipated in a brake resistor varies with the square of the voltage. To enable the maximum brake power to match that from the motor in Low Voltage DC mode, the brake resistor value must be reduced in proportion to the voltage, therefore a resistor is required in parallel with the normal operation brake resistor.

Please refer to the appropriate drive manual for the normal operating brake resistor values. The table below shows the R\_LVDC value resistor that is to be installed in parallel with the normal operation brake resistor.

**Table 5-4 Brake resistor values (R\_LVDC) for Unidrive SP 0 to 6**

Pr 6.46 Drive	48V			60V			72V			84V			96V		
	( $\Omega$ )	Peak power (kW)	Average power over 60s (kW)	( $\Omega$ )	Peak power (kW)	Average power over 60s (kW)	( $\Omega$ )	Peak power (kW)	Average power over 60s (kW)	( $\Omega$ )	Peak power (kW)	Average power over 60s (kW)	( $\Omega$ )	Peak power (kW)	Average power over 60s (kW)
SP0201 to 0205	6	0.67	0.49	7.5	0.84	0.61	10	0.91	0.73	N/A	N/A	N/A	N/A	N/A	N/A
SP1201 to 1203	7.4	0.55	0.49	N/A	N/A	N/A	N/A	N/A	N/A	N/A	N/A	N/A	N/A	N/A	N/A
SP1204	4.9	0.83	0.72	N/A	N/A	N/A	N/A	N/A	N/A	N/A	N/A	N/A	N/A	N/A	N/A
SP2201 to 2203	3.0	1.35	1.35	3.8	1.66	1.66	4.8	1.90	1.90	N/A	N/A	N/A	N/A	N/A	N/A
SP3201 to 3202	1.1	3.68	3.14	1.5	4.21	3.92	1.8	5.06	4.71	N/A	N/A	N/A	N/A	N/A	N/A
SP4201 to 4203	0.75	5.62	5.38	1.0	6.32	6.32	1.2	7.58	7.58	N/A	N/A	N/A	N/A	N/A	N/A
SP0401 to 0405	6	0.67	0.24	6	0.79	0.31	9	1.01	0.37	N/A	N/A	N/A	N/A	N/A	N/A
SP1401 to 1404	6.9	0.59	0.36	N/A	N/A	N/A	N/A	N/A	N/A	N/A	N/A	N/A	N/A	N/A	N/A
SP1405 to 1406	4.5	0.90	0.65	N/A	N/A	N/A	N/A	N/A	N/A	N/A	N/A	N/A	N/A	N/A	N/A
SP2401 to 2404	1.7	2.38	1.83	2.2	2.87	2.29	2.7	3.37	2.75	N/A	N/A	N/A	N/A	N/A	N/A
SP3401 to 3403	1.4	2.89	2.69	1.8	3.51	3.36	2.2	4.14	4.04	N/A	N/A	N/A	N/A	N/A	N/A
SP4401 to 4402	1.0	4.40	4.40	1.2	5.27	5.27	1.5	6.07	6.07	1.7	7.29	7.29	2.0	8.09	8.09
SP4403	0.7	5.86	5.50	0.9	7.02	6.88	1.1	8.27	8.26	1.3	9.53	9.53	1.5	10.79	10.79
SP5401	0.45	8.99	6.73	0.6	10.53	8.41	0.7	13.0	10.09	0.9	13.76	11.77	1.0	16.18	13.45
SP5402	0.45	8.99	8.99	0.6	10.53	10.53	0.7	13.0	13.0	0.7	13.76	13.76	0.8	20.22	18.35
SP6401 to 6402	0.35	11.9	11.90	0.5	12.64	12.64	0.6	15.17	15.17	0.7	17.70	17.70	0.7	23.11	23.11
SP3501 to 3507	1.4	3.00	1.54	1.8	3.51	1.92	2.1	4.33	2.31	N/A	N/A	N/A	N/A	N/A	N/A
SP4601 to 4606	0.9	4.49	3.83	1.2	5.27	4.79	1.4	6.50	5.75	1.7	7.29	6.71	1.9	8.52	7.67
SP5601 to 5602	0.7	5.95	5.95	0.9	7.02	7.02	1.1	8.27	8.27	1.3	9.53	9.53	1.5	10.79	10.79
SP6601 to 6602	Contact the drive supplier														

**Table 5-5 Brake resistor values (R\_LVDC) for Unidrive SPMA/D**

Pr 6.46	48V			60V			72V			84V			96V		
Drive	Peak power	Average power over 60s		Peak power	Average power over 60s		Peak power	Average power over 60s		Peak power	Average power over 60s		Peak power	Average power over 60s	
	(Ω)	(kW)	(kW)	(Ω)	(kW)	(kW)	(Ω)	(kW)	(kW)	(Ω)	(kW)	(kW)	(Ω)	(kW)	(kW)
SPMA 1401/2	0.35	11.9	11.9	0.5	12.64	12.64	0.6	15.17	15.17	0.7	17.70	17.70	0.7	23.11	23.11
SPMD 1401/2															
SPMD 1403	0.23	18	16.5	0.3	21.1	20.5	0.35	26	24.5	0.41	30.25	28.5	0.5	32.5	32.5
SPMD 1404	0.23	18	18	0.3	21.1	21.1	0.35	26	26	0.41	30.5	30.5	0.5	32.5	32.5
SPMA 1601/2	Contact the drive supplier														
SPMD 1601/2															
SPMD 1603															
SPMD 1604															
SPMD 1604															

Unlike Unidrive SP, the peak current rating of Digitax ST is three times the continuous drive rating. Some applications may use the peak rating for braking. For some models of Digitax ST, it is not possible to select a common value of R\_LVDC for both type of application. The minimum and maximum value for R\_LVDC is given in Table 5-6 for applications which use peak or continuous rating of the drive for braking.

**Table 5-6 Brake resistor values (R\_LVDC) for Digitax ST for Pr 6.46 = 48V**

Pr 6.46	48V										
Drive	Resistor for braking continuous drive power		Instantaneous power in resistor		Resistor for braking peak drive power		Instantaneous power in resistor		Average power in 0.25s	Common value of R_LVDC resistor selectable for both type of application	
	Min	Max	At min R	At max R	Min	Max	At min R	At max R			
	Ω	Ω	kW	kW	Ω	Ω	kW	kW	kW	Ω	
DST 1201	2.3	34	1.76	0.12	2.6	11	1.56	0.37	0.25	2.60	
DST 1202	4.1	15	0.99	0.27	2.6	5.2	1.56	0.78	0.57	4.10	
DST 1203	7.1	11	0.57	0.37	2.6	3.6	1.56	1.12	0.81	Common resistor value not selectable	
DST 1204	7.6	8	0.53	0.51	1.5	2.6	2.70	1.56	1.13	Common resistor value not selectable	
DST 1401	6	47	0.67	0.09	3.9	15	1.04	0.27	0.19	6.00	
DST 1402	6	26	0.67	0.16	3.9	8.7	1.04	0.46	0.34	6.00	
DST 1403	3.9	17	1.04	0.24	2.3	5.9	1.76	0.69	0.50	3.90	
DST 1404	4.2	12	0.96	0.34	1.5	4	2.70	1.01	0.73	Common resistor value not selectable	
DST 1405	4.2	8.8	0.96	0.46	1.5	2.9	2.70	1.39	1.00	Common resistor value not selectable	

**Table 5-7 Brake resistor values (R\_LVDC) for Digitax ST for Pr 6.46 = 60V**

Pr 6.46		60V								
Drive	Resistor for braking continuous drive power		Instantaneous power in resistor		Resistor for braking peak drive power		Instantaneous power in resistor		Average power in 0.25s kW	Common value of R_LVDC resistor selectable for both type of application  Ω
	Min Ω	Max Ω	At min R kW	At max R kW	Min Ω	Max Ω	At min R kW	At max R kW		
DST 1201	2.3	34	2.75	0.19	2.6	11	2.43	0.57	0.32	2.6
DST 1202	4.1	15	1.54	0.42	2.6	5.2	2.43	1.22	0.71	4.1
DST 1203	7.1	11	0.89	0.57	2.6	3.6	2.43	1.76	1.01	Common resistor value not selectable
DST 1204	7.6	8	0.83	0.79	1.5	2.6	4.21	2.43	1.42	Common resistor value not selectable
DST 1401	6	47	1.05	0.13	3.9	15	1.62	0.42	0.23	6
DST 1402	6	26	1.05	0.24	3.9	8.7	1.62	0.73	0.42	6
DST 1403	3.9	17	1.62	0.37	2.3	5.9	2.75	1.07	0.62	3.9
DST 1404	4.2	12	1.5	0.53	1.5	4	4.21	1.58	0.92	Common resistor value not selectable
DST 1405	4.2	8.8	1.5	0.72	1.5	2.9	4.21	2.18	1.25	Common resistor value not selectable

**Table 5-8 Brake resistor values (R\_LVDC) for Digitax ST for Pr 6.46 = 72V**

Pr 6.46		72V								
Drive	Resistor for braking continuous drive power		Instantaneous power in resistor		Resistor for braking peak drive power		Instantaneous power in resistor		Average power in 0.25s kW	Common value of R_LVDC resistor selectable for both type of application  Ω
	Min Ω	Max Ω	At min R kW	At max R kW	Min Ω	Max Ω	At min R kW	At max R kW		
DST 1201	2.3	34	3.96	0.27	2.6	11	3.5	0.83	0.38	2.6
DST 1202	4.1	15	2.22	0.61	2.6	5.2	3.5	1.75	0.85	2.6
DST 1203	7.1	11	1.28	0.83	2.6	3.6	3.5	2.53	1.21	Common resistor value not selectable
DST 1204	7.6	8	1.2	1.14	1.5	2.6	6.07	3.5	1.70	Common resistor value not selectable
DST 1401	6	47	1.52	0.19	3.9	15	2.33	0.61	0.28	6
DST 1402	6	26	1.52	0.35	3.9	8.7	2.33	1.05	0.50	6
DST 1403	3.9	17	2.33	0.54	2.3	5.9	3.96	1.54	0.75	3.9
DST 1404	4.2	12	2.17	0.76	1.5	4	6.07	2.28	1.10	Common resistor value not selectable
DST 1405	4.2	8.8	2.17	1.03	1.5	2.9	6.07	3.14	1.49	Common resistor value not selectable

### 5.3.1 Brake resistor rating and positioning

When a braking resistor is to be mounted outside the enclosure, ensure that it is mounted in a ventilated metal housing that will perform the following functions:

- Prevent inadvertent contact with the resistor
- Allow adequate ventilation for the resistor

For high-inertia loads or under continuous braking, the *continuous power* dissipated in the braking resistor may be as high as the power rating of the drive. The total *energy* dissipated in the braking resistor is dependent on the amount of energy to be extracted from the load.

The resistor ratings given in Table 5-4 are calculated for maximum braking power for the particular drive and operating voltage.

In most applications, braking occurs only occasionally. This allows the continuous power rating of the braking resistor to be much lower. It is essential, though, that the power rating and energy rating of the braking resistor are sufficient for the most extreme braking duty that is likely to be encountered.

Optimization of the braking resistor requires a careful consideration of the braking duty.

Select a value of resistance for the braking resistor that is not less than the specified minimum resistance. Larger resistance values may give a cost saving, as well as a safety benefit in the event of a fault in the braking system. Braking capability will then be reduced, which could cause the drive to trip during braking if the value chosen is too large.



#### Braking resistor: High temperatures and overload protection

Braking resistors can reach high temperatures. Locate the braking resistors so that damage cannot result. Use cable having insulation capable of withstanding the high temperatures. It is essential that the braking resistor is protected against overload caused by a failure of the brake control. Unless the resistor has in-built protection, a thermal overload relay should be fitted. In the event of the resistor becoming overloaded, the protection device must disconnect the AC and Low Voltage DC supply from the drive.

### 5.3.2 Sizing an appropriate thermal overload relay to protect the brake resistor

The 3 main considerations when calculating the thermal overload relay are as follows:

1. The thermal overload relay with the minimum tripping time must not trip with the brake current pulse.
2. The peak current through the resistor must not damage the overload relay, this can be checked using the equation shown in the worked example below.
3. The brake resistor capability must be greater than the thermal overload relay with maximum tripping time.

#### Worked example

Select a thermal overload relay for an SP1401 operating in normal duty, which will be braking at 150% of the normal duty rating with a deceleration time of 5 seconds.

#### Additional data

From Table 5-4 on page 34 the value of  $R_{LVDC}$  will be  $6.9\Omega$ .

From section 3.1.2 *Low Voltage DC rating* on page 10 the LVDC brake turn on voltage will be:

$$1.325 \times Pr \mathbf{6.46} (48V) = 63.6V$$

$$\text{Normal operation brake turn on voltage} = 780V$$

### 1. To calculate the thermal overload relay setting ( $I_{set}$ )

Power from motor at 48V =

$$\begin{aligned} \text{Nominal motor power} \times \text{Overload \%} \times \frac{\text{LVDC brake turn on voltage}}{\text{Normal operation brake turn on voltage}} \\ = 1100\text{W} \times 150\% \times \frac{63.6\text{V}}{780\text{V}} = 135\text{W} \end{aligned}$$

Peak current over the braking period =

$$\begin{aligned} I_{rms}(\text{peak}) &= \sqrt{\frac{\text{Peak power at beginning of brake period (W)}}{\text{Brake resistor value } (\Omega)}} \\ &= \sqrt{\frac{135\text{W}}{6.9\Omega}} = 4.4\text{A} \end{aligned}$$

Use the minimum tripping curves for the chosen manufacturer of thermal overload relay in order to find the overload factor (F) that will cause the relay to trip after 5 seconds.

The tripping curve below is for a class 10A thermal overload relay.

**Figure 5-1 Class 10A thermal overload relay tripping characteristics**

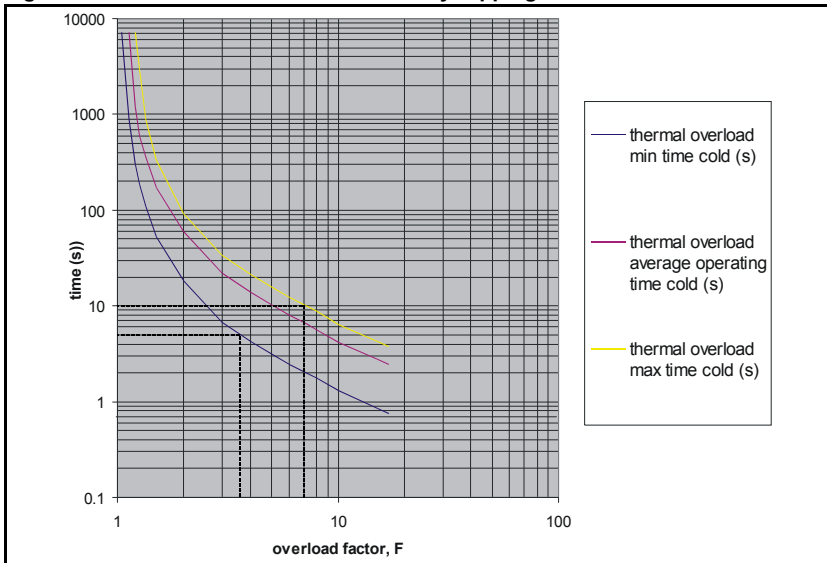

From the thermal overload relay-tripping curve above it can be seen that at 5 seconds the overload factor (F) will be approximately 3.5.

From the above information the thermal overload relay setting ( $I_{set}$ ) will be:

$$\begin{aligned} I_{set} &= \frac{I_{rms}(\text{peak})}{\text{Overload factor}(F)} \\ I_{set} &= \frac{4.4}{3.5} = 1.26\text{A} \end{aligned}$$

Select a model of thermal overload relay that can be set at 1.26A. (e.g. Telemecanique LRD-06).

## 2. Calculate the maximum fault current under fault conditions [ $I_r(\text{peak})$ ]

Calculate the maximum current that could flow through the resistor (e.g. due to the braking transistor becoming short circuit).

$$I_r(\text{peak}) = \frac{\text{LVDC brake turn on voltage (V)}}{R} = \frac{63.6\text{V}}{6.9\Omega} = 9.2\text{A}$$

Check that the maximum current under fault conditions is less than 17 times the current setting of the thermal overload relay.

**Overload factor (F) with short circuit =**

$$\frac{I_r(\text{peak})}{I_{\text{set}}} = \frac{9.2\text{A}}{1.26\text{A}} = 7.3$$

This is less than 17 times so this thermal overload relay would be suitable.

### NOTE

If the overload factor (F) is more than 17 times the current setting of the thermal overload relay, then an in-line fuse would need to be considered. In this case refer to the thermal overload relay manufacturers recommendations.

## 3. Check that the chosen resistor can tolerate the overload

Use the maximum time tripping curve to determine the time that corresponds to a factor (F) of 7.3

From the maximum time tripping curve you get a time of approximately 10 seconds for a factor (F) of 7.3.

Check that the braking resistor can tolerate 9.2A for 10 seconds.

## 5.4 External soft start resistor

**Table 5-9 Resistor values**

Drive	Rs ( $\Omega$ )	Power rating (W)	Energy rating (J)	Resistor part number	Resistor combination
SP020X				N/A	
DST120X					
SP1202 to SP1204					
SP2201 to SP2203					
SP3201 to SP3202					
SP4201 to SP4203	48	148	1700	1270-2483	1270-2483
SP040X				N/A	
DST140X					
SP1401 to SP1406					
SP2401 to SP2404					
SP3401 to SP3403					
SP4401 to SP4403	96	296	3400	1270-2483	2x1270-2483 in series
SP5401 to SP5402					
SP6401 to SP6402					
SPMA1401 to SPMA1402					
SPMD1401 to SPMD1404					
SP3501 to SP3507	N/A	N/A	N/A	N/A	N/A
SP5601 to SP5602	96	296	3400	1270-2483	2x1270-2483 in series
SP6601 to SP6602					
SPMA1601 to SPMA1602					
SPMD1601 to SPMD1604					

### 5.4.1 External soft start resistor protection

To protect the soft start resistor from becoming damaged in a failure situation, a suitable fuse needs to be installed in series with the resistor. The fuse must meet the specification as detailed below.

**Table 5-10 Fuse values**

Drive voltage rating (V)	F4 current rating (A)	F4 DC voltage rating (V)	Recommended fuse type (Ferraz)	Alternative fuse type
200	1	500	ATM	As set out below
400/575/690	1	1000	A 120X	As set out below

#### Alternative fuse types

An alternative to the fuses recommended in Table 5-10 can be used providing the fuse time vs current characteristic lies between the curves shown in the graphs below and the voltage rating is as per the value shown in Table 5-10.

**Figure 5-2 200V drive time vs current fuse characteristic specification**

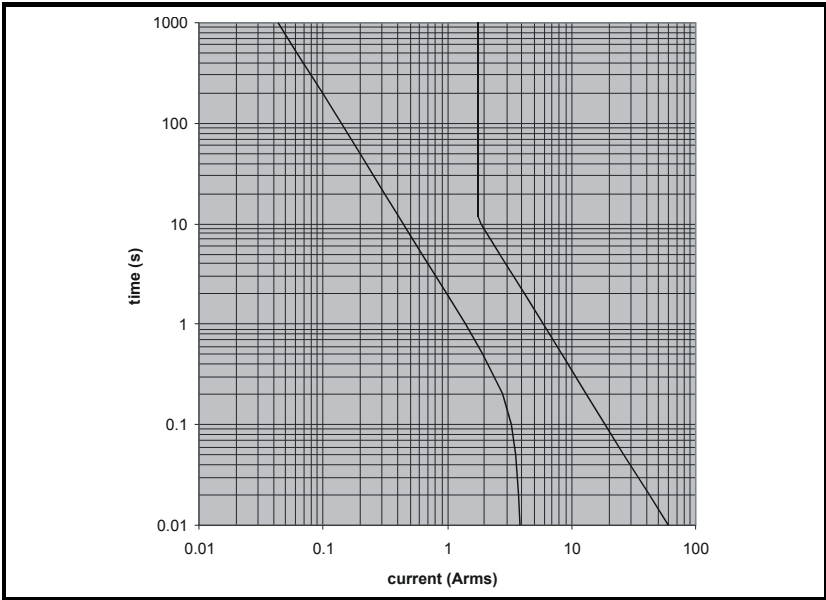

**Figure 5-3 400V drive time vs current fuse characteristic specification**

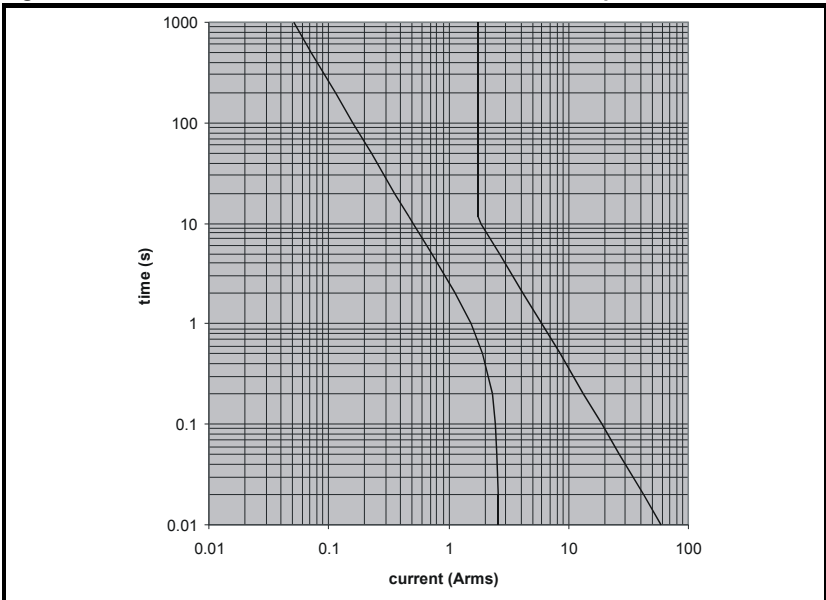

**Figure 5-4 575V/690V drive time vs current fuse characteristic specification**

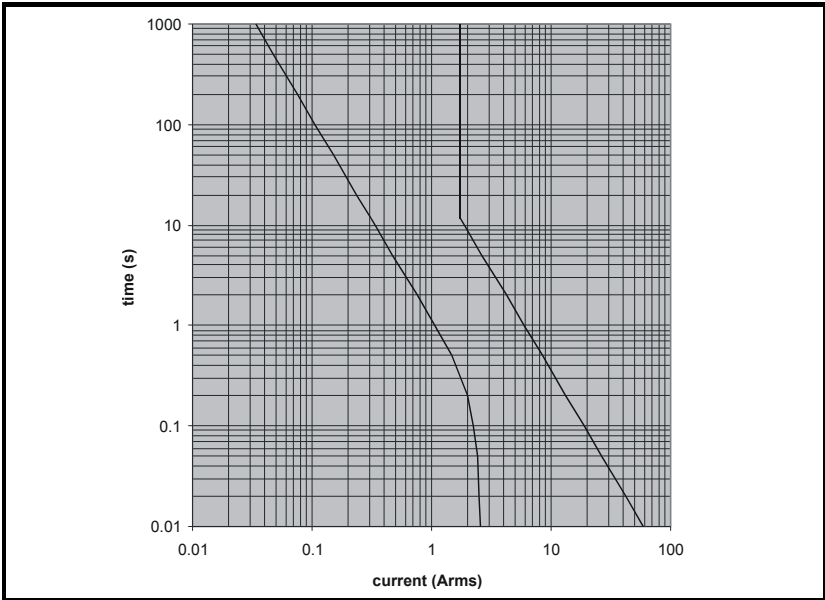

## 5.5 Blocking diode (D1)

The blocking diode D1 is used to prevent energy from being returned into the Low Voltage DC supply.

**Table 5-11 D1 specification**

Drive voltage rating V	Diode type	Working current A	Voltage rating V
200	Standard recovery	3 x drive output current rating	600
400			1200
575			1500
690			

A suitable supplier for the above diode can be Semikron™ with the SKKE isolated base module diode. The diode must be mounted on a suitable heatsink. See manufacturer data for heatsink requirements of the device.

## 5.6 Supply capacitor (C1)

**Table 5-12 C1 specification**

Suitable capacitor type	Capacitor value nF	Voltage rating V
Metalized polyester	100	≥250

**NOTE** This capacitor is only required with the Unidrive SP size 1. The capacitor should be connected directly to the drive terminals.

## 5.7 Supplier websites

**NOTE**

This capacitor is only required with the Unidrive SP size 1. The capacitor should be connected directly to the drive terminals.

**Resistors**

- [www.pentagonelectric.co.uk](http://www.pentagonelectric.co.uk)
- [www.cressall.com](http://www.cressall.com)
- [www.reo.co.uk](http://www.reo.co.uk)

**Contactors and thermal overload relays**

- [www.telemecanique.com](http://www.telemecanique.com)
- [www.abb.com](http://www.abb.com)
- [www.omron.co.uk](http://www.omron.co.uk)

**Fuses**

- [www.ferrazshawmut.com](http://www.ferrazshawmut.com)
- [www.bussmann.co.uk](http://www.bussmann.co.uk)

**Diodes**

- [www.semikron.com](http://www.semikron.com)
- [www.ixys.com](http://www.ixys.com)

---

# Index

---

<b>A</b>	
Autotuning .....	29
<b>B</b>	
Brake resistor .....	34
<b>C</b>	
Compliance .....	5
<b>D</b>	
Discharge resistor and protection .....	33
Drive control 24V rating .....	11
<b>E</b>	
Electrical safety .....	4
Environmental limits .....	5
External soft start circuit control .....	27
External soft start resistor .....	40
<b>F</b>	
Fusing .....	30, 32, 40
<b>I</b>	
Important considerations and information .....	14
<b>L</b>	
Low Voltage DC mode enable rating .....	11
Low Voltage DC operating range .....	7
Low Voltage DC rating .....	10
Low Voltage DC speed limitation .....	8
Low Voltage DC Supply types .....	13
<b>O</b>	
Operating modes .....	8
<b>P</b>	
Parameters - adjusting .....	6
Power circuit control logic and sequencing .....	24
Pr 6.44 .....	14
Pr 6.46 .....	10
Preventing over-voltage trips .....	19
<b>R</b>	
Required connections for low voltage DC operation .....	12
Running the motor .....	29
<b>S</b>	
SAFE TORQUE OFF .....	4
Safety of personnel .....	4
Supplier websites .....	43
System configuration .....	14, 17, 20, 22





**0471-0060-02**