



More Precision.

Display units

Signalvisualisation and computing





- Process display for 2 rotation speeds/ velocities
- Display 6-digits
- Connection: Sensors with incremental digital output
- Two limits as optocoupler
- Peak value memory
- Input F1 with phase evaluation
- Calculating functions

The process display DD202TA evaluates rotational/speed signals. Production can be controlled with two programmable limit switches (relay contacts). For internal evaluation of the signals, several programmed calculating functions are available: ratio, difference, stretching/shrinking, flow, time elapsed with start and stop signal, impulse rate measurement, period or impulse duration.

Additional equipment model DD202TA(01)

- Interface RS232
- Analogue output
- Two limits as relay outputs

DD202TA

(Dimensions in mm, not to scale)

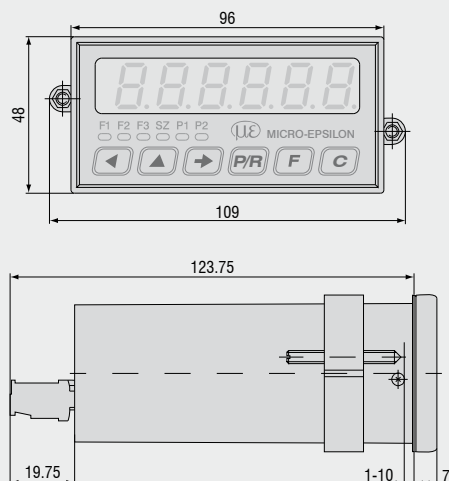

Block circuit diagram

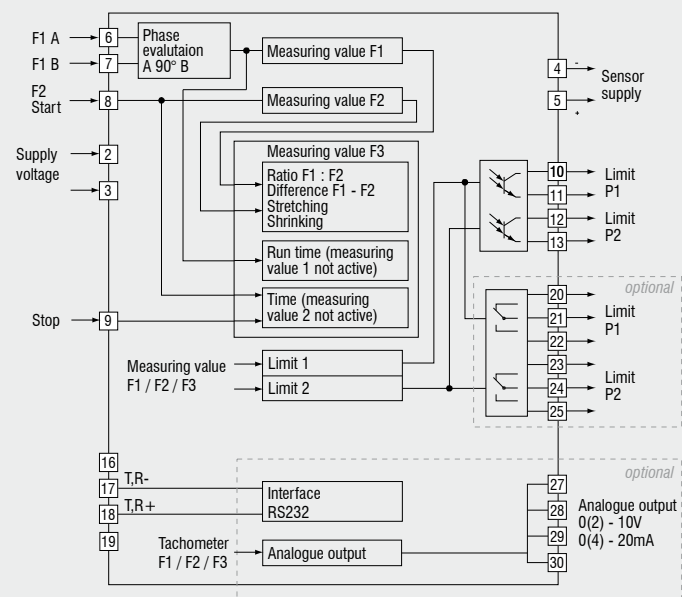

Model	DD202TA
Power supply	24VDC \pm 10%
Power consumption	7VA, 5W
Sensor supply	12...26VDC / max. 100mA
Display	LED, 7-segment display
Number of digits	6-digits
Digit height	14mm
Unit displayed	1/s, 1/min, 1/h programmable
Function	Tachometer, ratio display
Measuring principle	Period duration measurement
Calculating functions	Difference F1-F2; ratio F1:F2; stretching/shrinking (F2-F1):F1: flow, impulse rate measurement
Signal inputs	Comparator inputs
Input logic	NPN / PNP
Control inputs	2 inputs
Control functions	Start, stop
Counting frequency	F1: 10kHz / F2: 25Hz, 40kHz
Scaling factor	0.0001 ... 9999.999
Data memory	> 10 years in EEPROM
Outputs electronic	Optocoupler
Outputs relay	Potential-free change-over contact (optional)
Analogue output	optional: 2 analogue outputs 0(2)...10V, 0(4)...20mA; resolution 12 bit; temperature coeffic. typ. \pm 20ppm/ $^{\circ}$ C
Interfaces	RS232 (optional)
Standard DIN EN 61010-1	Protection class II; overvoltage category II; pollution degree 2
Emitted interference	DIN EN 61000-6-3
Interference immunity	DIN EN 61000-6-2
Programmable parameters	Assignment F1, F2 or F3; calculating functions; 2 limits; analogue output; slave pointer
Approvals	UL/cUL, CE-conform
Temperature	Operating: -10...+50 $^{\circ}$ C; storing: -20...+70 $^{\circ}$ C
Relative humidity	80%, non-condensing
E-connection	Plug-in screw terminals
Core cross-section	1.5mm ²
Protection DIN EN 60529	IP 65 face with seal
Operation / keypad	Membrane with softkeys
Housing type	Housing for control panel installation
Dimensions	W x H x L 96 x 48 x 124mm
Cutout dimensions	96 x 45mm (+0.6)
Installation depth	123.75mm
Mounting	Front panel installation by clip frame
Weight	Approx. 350g (AC), 250g (DC)
Material housing	Makrolon 6485 (PC)



DD214NE is a display for two digital sensor signals. The display has several integral counting functions. With option 01, the display becomes a process display. Production can be controlled with two programmable limit switches (relay contacts).

Additional equipment model DD214NE(01)

- Interface RS232
- Analogue output
- Two limits as relay output

- Process display for incremental measurement
- Display 6-digits
- Operating mode, start count, scaling factor, momentary signal time programmable
- Connection: Sensors with incremental digital output
- Adjustable Scaling factor 0.0001 ... 9999.99
- Two limits as optocoupler

DD214NE

(Dimensions in mm, not to scale)

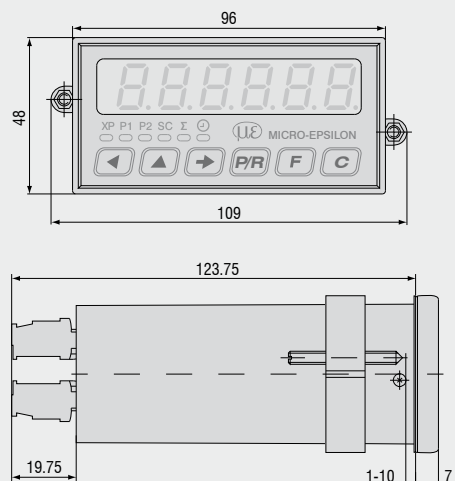

Block circuit diagram

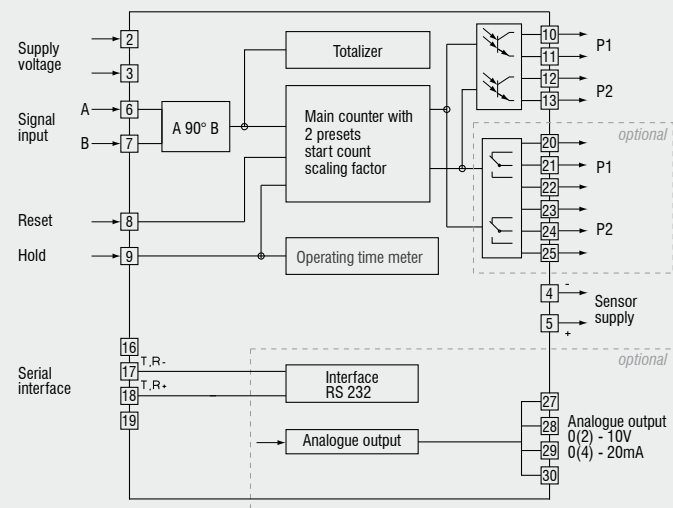

Model	DD214NE
Power supply	24VDC \pm 10%
Power consumption	7VA, 5W
Sensor supply	12...26VDC / max. 100mA
Display	LED, 7-segment display
Number of digits	6-digits
Digit height	14mm
Function	preset counter; main counter with 2 presets; batch counter with 1 preset; totalizer; hour counter
Scaling factor	0.0001 ... 9999.99
Multiplier / batch counter	1...999
Count modes	Adding or subtracting; A-B (difference counting); A+B total (parallel counting); Up/Down, A 90° B phase evaluation
Counting frequency	3Hz, 25Hz, 10kHz programmable
Operating modes	Step preset, main preset, parallel alignment, trailing preset
Data memory	>10 years in EEPROM
Reset	Button, electric or automatic
Outputs electronic	Optocoupler
Outputs relay	Potential-free change-over contact (optional)
Output holding time	0.01 ... 99.99s
Analogue output	0(2)...10V, 0(4)...20mA (optional)
Interfaces	RS232 (optional)
Standard DIN EN 61010-1	Protection class II; overvoltage category II; pollution degree 2
Emitted interference	DIN EN 61000-6-3
Interference immunity	DIN EN 61000-6-2
Programmable parameters	Operating modes, sensor logic, scaling factor, count mode, control input
Approvals	UL/cUL, CE conform
Temperature	Operating: -10...+50°C; Storing: -20...+70°C
Relative humidity	80%, non-condensing
E-connection	Plug-in screw terminals
Core cross-section	1.5mm ²
Protection DIN EN 60529	IP 65 face with seal
Operation / keypad	Membrane with softkeys
Housing type	Built-in housing
Dimensions	W x H x L 96 x 48 x 124mm
Cutout dimensions	96 x 45mm (+0.6)
Installation depth	123.75mm
Mounting	Clip frame
Weight	Approx. 350g (AC), 250g (DC)
Material housing	Makrolon 6485 (PC)



- Display 6-digits
- Connection: One-channel analogue sensor
- With peak value memory
- Tara function

DD241PC is a single channel process display for analogue sensors. Each sensor with analogue signal between 0(4) ... 20mA, 0(2) ... 10V can be connected. Two programmable limits are used to monitor tolerance limits. Typical applications are distance surveillance to a measurement object or control, if two objects lay on top of each other in production line.

Additional equipment model DD241PC(11)

- Interface RS232
- Two limits as relay output

DD241PC

(Dimensions in mm, not to scale)

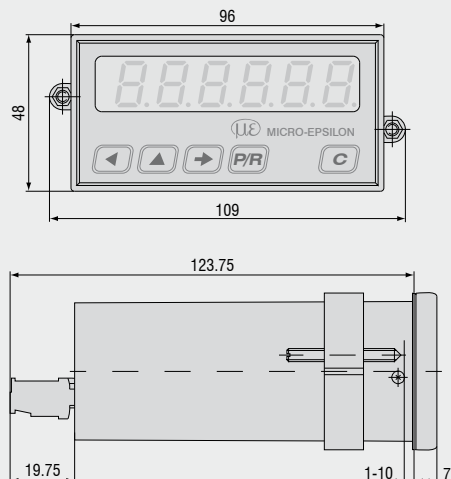

Block circuit diagram

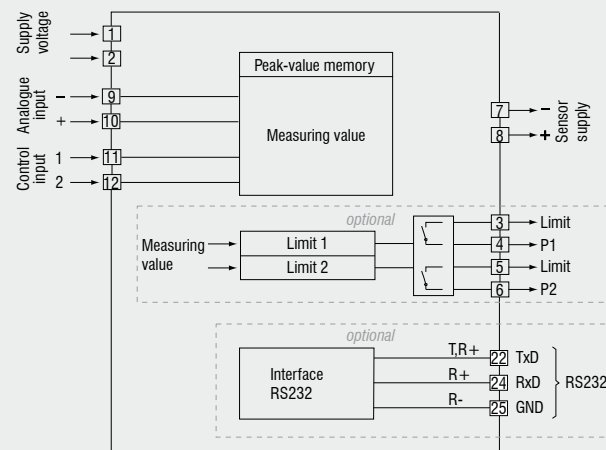

Model	DD241PC
Power supply	12...30VDC
Power consumption	6VA, 4W
Sensor supply	12...26VDC / max. 80mA
Display	LED, 7-segment display
Number of digits	6-digits
Digit height	14mm
Function	Digital display of 1 analogue measured value; peak value memory (slave pointer), tara function
Measuring principle	Analogue, resolution 12 bit
Accuracy (excl. temp. coeffic.)	±0.1% FSO
Input logic	PNP
Control inputs	2 Inputs
Control functions	Hold, Reset, Keylock, etc.
Data memory	> 10 years in EEPROM
Analogue input	0(2)...10V; 0(4)...20mA; resolution 12 Bit; temp. coeffic. typ. ±20 ppm/°C
Outputs relay	Normally open or closed, programmable (optional)
Interfaces	RS232 (optional)
Standard DIN EN 61010-1	Protection class II; overvoltage category II; pollution degree 2
Emitted interference	DIN EN 61000-6-3
Interference immunity	DIN EN 61000-6-2
Programmable parameters	2 limits (optional), analogue input; control inputs; offset (maximum and minimum analogue limit)
Approvals	UL/cUL, CE conform
Temperature	Operating: -10...+50°C; storing: -20...+70°C
Relative humidity	80 % non-condensing
Core cross-section	1.5mm ²
Protection DIN EN 60529	IP 65 face with seal
Operation / keypad	Membrane with softkeys
Housing type	Housing for control panel installation
Dimensions	W x H x L 96 x 48 x 124mm
Cutout dimensions	94 x 45mm (+0.6)
Installation depth	123.75mm
Mounting	Front panel installation by clip frame
Weight	Approx. 350g (AC), 250g (DC)
Material housing	Makrolon 6485 (PC)

High performance sensors made by Micro-Epsilon



Sensors and systems for displacement and position



Measurement and inspection systems for quality assurance



Sensors and measurement devices for non-contact temperature measurement



Optical micrometers, fibre optic sensors and fibre optics



2D/3D profile sensors (laser scanner)



Colour recognition sensors, LED analyzers and colour online spectrometer

**SCIENCE
GATE**
Your Automation Partner



SCIGATE AUTOMATION (S) PTE LTD

No.1 Bukit Batok Street 22 #01-01 Singapore 659592

Tel: (65) 6561 0488

Fax: (65) 6562 0588

Email: sales@scigate.com.sg

Web: www.scigate.com.sg

Business Hours: Monday - Friday 8.30am - 6.15pm



MICRO-EPSILON Headquarters
Koenigbacher Str. 15 · 94496 Ortenburg / Germany
Tel. +49 (0) 8542 / 168-0 · Fax +49 (0) 8542 / 168-90
info@micro-epsilon.com · www.micro-epsilon.com