



More Precision

optoNCDT // Laser Triangulation Displacement Sensors





-  **Laser Line averages across shiny metallic or structured surfaces**
-  **Four models with measuring ranges from 2mm to 50mm**
-  **Adjustable measuring rate up to 49.02kHz**
- INTER FACE** **Ethernet / EtherCAT / RS422**
Analogue output via C-Box
-  **Advanced Real-Time-Surface-Compensation**
-  **Calibration certificate included**
-  **Configuration via Web-Interface**

The optoNCDT 2300LL series use a very small laser line instead of the common laser spots. Due to this laser line, the optoNCDT 2300LL is very well suited for precise distance and displacement measurement on glossy, porous or rough surfaces. Due to the high measurement rate of up to 49kHz it is possible to reliably apply the sensor in fast processes. The data are output via Ethernet, EtherCAT or RS422. The complete sensor configuration is effected via a comfortably designed web interface.

optoNCDT 2300LL

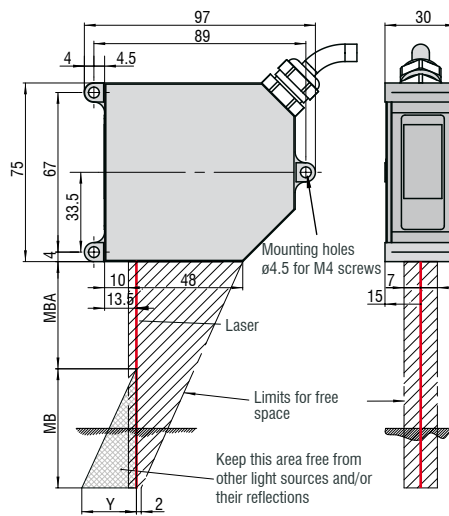

MB	MBA	Y
2	24	1.5
10	30	6.5
20	40	10.0
50	45	23.0

Modell	ILD 2300-2LL	ILD 2300-10LL	ILD 2300-20LL	ILD 2300-50LL	
Measuring range ¹⁾	2 (2) mm	10 (5) mm	20 (10) mm	50 (25) mm	
Start of measuring range	24 (24) mm	30 (35) mm	40 (50) mm	45 (70) mm	
Midrange	25 (25) mm	35 (37,5) mm	50 (55) mm	70 (82,5) mm	
End of measuring range	26 (26) mm	40 (40) mm	60 (60) mm	95 (95) mm	
Linearity	0.6µm	2µm	4µm	10µm	
	≤ ±0.03% FSO		≤ ±0.02% FSO		
Resolution (20kHz)	0.03µm	0.15µm	0.3µm	0.8µm	
	0.0015% FSO				
Measuring rate	adjustable via software 49.02 / 30 / 20 / 10 / 5 / 2.5 / 1.5kHz (49.02kHz with reduced measuring range)				
Permissible ambient light	10,000...40,000lx				
Spot diameter	SMR	85 x 240µm	120 x 405µm	185 x 485µm	350 x 320µm
	MMR	24 x 280µm	35 x 585µm	55 x 700µm	70 x 960µm
	EMR	64 x 400µm	125 x 835µm	195 x 1200µm	300 x 1940µm
Light source	laser diode (670nm) class 2				
Protection class	IP 65				
Operation temperature	0 ... +50°C				
Storage temperature	-20 ... +70°C				
Inputs / Outputs	Ethernet / EtherCAT RS422 analogue output via CSP2008 / C-Box				
Inputs	laser on/off; synchronization/trigger input				
Power supply	24Vdc (11...30V); PV < 3W				
LED	status / power / Ethernet / EtherCAT				
Sensor cable	standard	0.25m (with cable connector)			
	option	3 / 6 / 9m with Sub D 15 pin connector			
Electromagnetic compatibility (EMC)	EN 61326-1: 2006-10 DIN EN 55011: 2007-11 (group 1. class B) EN 61 000-6-2: 2006-03				
Vibration	2g / 20 ... 500Hz				
Shock	15g / 6ms / 3 axes				

FSO = Full Scale Output All specifications apply for a diffusely reflecting matt white ceramic target

SMR = Start of measuring range MMR = Midrange EMR = End of measuring range

¹⁾ Numbers in brackets refer to full measurement rate 49.02kHz

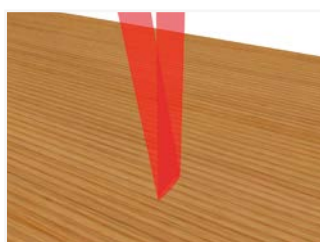
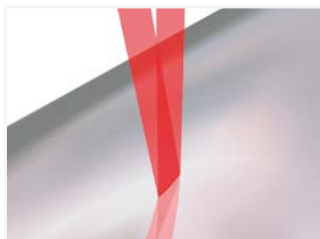

Accessories for all optoNCDT Series**Power supply**

- PS 2020 (Power Supply 24 V / 2,5 A, Input 100 - 240 VAC, output 24 VDC / 2,5 A, for snap in mounting on DIN 50022 rail)

Controller

- CSP 2008 (controller for processing of multiple sensor signals; analogue and digital interfaces)

Interface card

- IF2008 (Interface card for individual signal processing; analogue and digital interfaces)

Converter

- IF2004/USB 4 Channel RS422/USB Converter

Accessories optoNCDT 1302/1402/1402SC**Supply and output cable, rated for moving cable tracks**

(also available in 90° version)

- PC 1402-3/I (3m, output 4 ... 20mA)
- PC 1402-6/I (6m, output 4 ... 20mA)
- PC 1402-3/U (3m, with integral resistance, output 1 ... 5VDC)
- PC 1402-6/U (6m, with integral resistance, output 1 ... 5VDC)
- PC1402-3/IF2008 (3m, supply and output cable)
- PC 1402-3/USB (3m, supply and output cable)
- PC1401/1402-0.2 (0.2m, adapter cable 12-pin to 7-pin)
- PC 1402-3/CSP (3m, required for CSP 2008, optoNCDT 1402 only)

Supply and output cable, robot rated

(available in 90° version)

- PCR 1402-3/I (3m)
- PCR 1402-6/I (6m)
- PCR 1402-8/I (8m)

Supply and output cable 1402SC

- PC1402SC-3/I (3m, output 4...20 mA)
- PC1402SC-8/I (8m, output 4...20 mA)
- PC1402SC-10/I (10m, output 4...20 mA)
- PC1402SC-3/U (3m, output 1...5 V)
- PC1402SC-6/U (6m, output 1...5 V)
- PC1402SCT-3/I (3m, output 4...20 mA)
- PC1402SC-12/IF2008 (12m, supply and output cable)

Protective housing

- SGH ILD 1402(01)
- SGHF ILD 1402(01)

Accessories optoNCDT 1610 / 1630**Supply and output cable**

- PC 1605-3 (3m)
- PC 1605-6 (6m)
- PC 1607-5/BNC (5m, BNC connector)

Accessories optoNCDT1700/1700LL/1700BL**Supply and output cable (drag chain rated)**

- PC 1700-3 (3m)
- PC 1700-10 (10m)
- PC 1700-10/3/IF2008 (10m, for use with interface card IF2008)
- PC 1700-3/T (3m, for use with trigger box)
- PC 1700-10/T (10m, for use with trigger box)
- PC 1700-3/USB (3m, with USB-RS422-converter, power supply 90 ... 230 VAC)

Supply and output cable (robot rated)

- PCR 1700-5 (5m)
- PCR 1700-10 (10m)

Protective housing

- SGH (size S and M)
- SGHF (size S and M)

Accessories optoNCDT 2300**Supply and output cable**

- PC2300-0,5Y (Connecting cable to PC or SPS; for operation a PC2300-3/SUB-D will be required)
- PC2300-3/SUB-D (3m; for operation a PC2300-0,5Y will be required)
- PC2300-3/CSP (3m, connecting cable ILD2300 and CSP2008)
- PC2300-10/CSP (10m, connecting cable ILD2300 and CSP2008)
- PC2300-15/CSP (15m, connecting cable ILD2300 and CSP2008)
- PC2300-3/IF2008 (3m, interface and supply cable)
- PC2300-3/OE (3m)
- PC2300-6/OE (6m)
- PC2300-9/OE (9m)
- PC2300-15/OE (15m)

Protective housing

- SGH (size S and M)
- SGHF (size S and M)

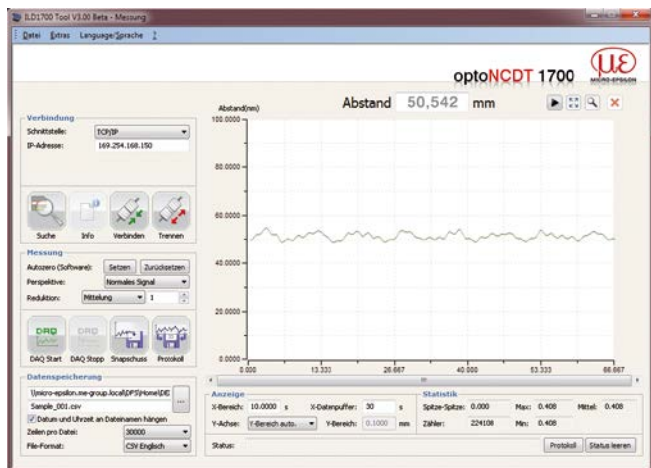

Setup and configuration software

ILD Tools is the software included for easy sensor configuration. All the settings can be implemented conveniently via a Windows user interface on the PC. The sensor parameters are sent to the sensor via the serial port and can also be saved if required. ILD Tools also includes a module which can display and save measurement results. The link to the PC is made via the sensor cable with a USB converter. [available for all series except 16x0]

Driver support for customer software

For the optoNCDT sensors documented DLL drivers are available free of charge, which enables easy integration of the sensors into existing software. Software download free of charge from www.micro-epsilon.com/download

Protective housing for harsh environment

To protect the laser sensors in extreme environments individual protective housings are available for all sensor models. Three options for the protective housing are offered.

Option SGH:

Completely enclosed housing with an integrated front window, where the sensor measures through the window. The water resistant housing provides protection against solvents and detergents.

Option SGHF:

The SGHF version offers optimum protection for the sensor with integrated compressed air cooling and provides protection against fluids.

SGH ILD 1402(01) & SGHF ILD 1402(01)
for optoNCDT 1402(025)

SGx ILD size S (140x140x71mm)
for optoNCDT 1700 / 2300
dimensions 97x75mm

SGx ILD size M (140x180x71mm)
for optoNCDT 1700 / 2300
dimensions 150x80mm



IF2008 - PCI interface card

The IF 2008 interface card is designed for installation in PCs and enables the synchronous capture of 4 digital sensor signals and 2 encoders. The absolutely synchronous data acquisition plays an important role particularly for planarity or thickness measurement tasks. The data are stored in a FIFO memory in order to enable resource-saving processing in the PC in blocks.

Particular Benefits

- 4x digital signals and two encoders with basic printed circuit board
- Additional expansion board for a total of 6x digital signals, 2x encoder and 2x analogue signals and 8x I/O Signals
- FIFO data memory
- Synchronous data acquisition



IF2008E - Expansion board

The IF 2008E expansion board is designed for installation in PCs and enables the synchronous capture of 2 digital sensor signals and 2 encoders as well as 8 I/O-Signals. The expansion board is connected to the basis board IF2008. The absolutely synchronous data acquisition plays an important role particularly for planarity or thickness measurement tasks.

Particular Benefits

- Two digital signals, two analogue signals and 8 I/O signals
- Overall with IF2008: 6 digital signals, 2 encoders and 2 analogue signals and 8 I/O Signals
- FIFO data memory
- Synchronous data acquisition

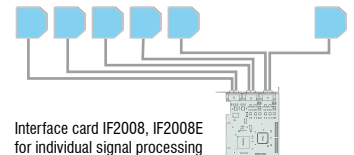

Interface card IF2008, IF2008E for individual signal processing

IF2004/USB 4 Channel RS422/USB Converter

The RS422/USB converter is used for transforming digital signals from up to 4 ILD sensors into USB data signals. Equipped with 4 trigger inputs and 1 trigger output additional USB converters can be adapted.

Particular Benefits

- 4x digital signals via RS422
- 4 trigger inputs, 1 trigger output
- Synchronous data acquisition
- USB interface



C-Box controller for up to 2 displacement signals

The C-Box is a compact controller for the digital-to-analogue conversion of a digital sensor signal and for the evaluation of two digital sensor signals. The output occurs via parameterisable analogue output, Ethernet, RS422 or USB. Besides the averaging and statistics function the measurement of thickness, average, step or tilting is possible. The C-Box may be used with ILD2300 and IFC2451/2471. The digital-to-analogue conversion happens with 16 Bit and 70 kHz maximum.



CSP2008 - Universal controller for up to six sensor signals

The controller CSP2008 has been designed to process 2 to 6 both optical and other sensors from Micro-Epsilon (6 digital or 4 analogue input signals max., 2x internal + 4x external via EtherCAT modules from the company Beckhoff. EtherCAT is intended as external bus for connecting further sensors and I/O modules. The controller is equipped with a display offering multicolour backlighting which changes its color in the case of exceeding the limit value while a signal is displayed.

Features

- Real-time processing of input and output signals at up to 100kHz (user selectable)
- Unique user interface for the configuration of the controller via Ethernet on a PC or laptop. All user selectable functions of the controller and the measured values can be viewed, displayed and stored in real time via your own web browser without installing any 3rd part software
- Simple sensor connection with automatic sensor recognition, configuration of the sensor using buttons and display on controller or via web browser
- Modular system upgradable with additional I/O modules for customer-specific requirements. The internal communication between I/O components using EtherCAT connection (CSP 2008 acts as master)
- Extremely flexible and powerful functionality; function modules can be combined in many ways.
- Simple mounting using DIN rail TS 35



System setup

Sensors via RS422

- optoNCDT 1302
- optoNCDT 1402
- optoNCDT 1700
- optoNCDT 2300
- optoCONTROL 2500
- optoCONTROL 2600
- confocalDT 2451/2471

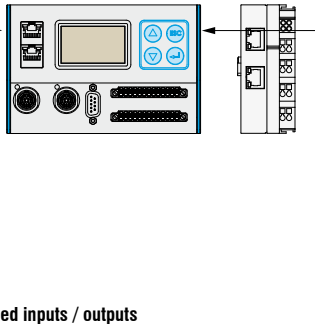

Beckhoff modules for extended inputs / outputs

- EK1100, EtherCat bus coupler
- EL4102, Analogue output terminal 0 V bis +10 V, 2 channels (16 Bit), EtherCAT
- EL4132, Analogue output terminal -10 V bis +10 V, 2 channels (16 Bit), EtherCAT
- EL4024, Analogue output terminal 4 ... 20 mA, 4 channels (12 Bit), EtherCAT
- EL2002, Digital output terminal, 24 VDC/ 0,5 A, 2 channels, EtherCAT
- EL2002, Digital output terminal, 24 VDC/ 0,5 A, 2 channels, EtherCAT
- EL2004, Digital output terminal, 24 VDC/ 0,5 A, 4 channels, EtherCAT
- EL3142, Analogue input terminal 0 ... 20 mA, 2 channels (16 Bit), EtherCAT
- EL3162, Analogue input terminal 0 ... 10 V, 2 channels (16 Bit), EtherCAT
- EL1002, Digital input terminal 24 VDC/3 ms, 2 channels, EtherCAT
- EL1012, Digital input terminal 24 VDC/10 μs, 2 channels, EtherCAT
- EL1014, Digital input terminal 24 VDC/10 μs, 4 channels, EtherCAT
- EL1104, Digital input terminal 24 VDC/3 ms, 4 channels, EtherCAT
- EL5101, Incremental encoder interface, RS485 differential inputs, EtherCAT
- EK1122, 2-Port EtherCAT junction
- RS422 extension terminal

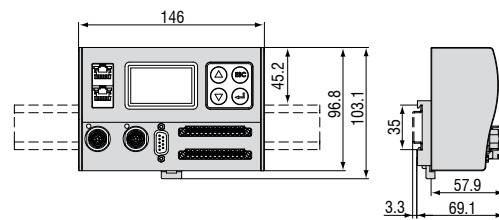

Universal controller with DIN rail TS 35
(dimensions not to scale)

High performance sensors made by Micro-Epsilon



Sensors and systems for displacement and position



Sensors and measurement devices for non-contact temperature measurement



2D/3D profile sensors (laser scanner)



Optical micrometers, fibre optic sensors and fibre optics



Colour recognition sensors, LED analyzers and colour online spectrometer

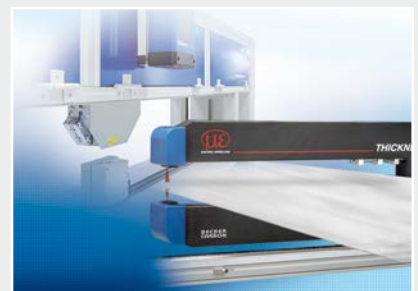

Measurement and inspection systems



SCIGATE AUTOMATION (S) PTE LTD

No.1 Bukit Batok Street 22 #01-01 Singapore 659502
 Tel: (65) 6561 0488 Fax: (65) 6562 0588
 Email: sales@scigate.com.sg Web: www.scigate.com.sg

Business Hours: Monday - Friday 8.30am - 6.15pm



MICRO-EPSILON

MICRO-EPSILON Headquarters
 Koenigbacher Str. 15 · 94496 Ortenburg / Germany
 Tel. +49 (0) 8542 / 168-0 · Fax +49 (0) 8542 / 168-90
 info@micro-epsilon.com · www.micro-epsilon.com

MICRO-EPSILON UK Ltd.
 No.1 Shorelines Building · Shore Road · Birkenhead · CH41 1AU
 Phone +44 (0) 151 355 6070 · Fax +44 (0) 151 355 6075
 info@micro-epsilon.co.uk · www.micro-epsilon.co.uk