



Rethinking Sensing Technology

Quick Start / X-SOLAR-7AH and X-SOLAR-14AH for Willow® and 2.4GHz sensor series

Youssef SHAHINE
BeanAir GmbH

V1.3- 10/02/2022



X-SOLAR-7AH





List of accessories provided with your X-SOLAR-7AH

- 2x M8 Plugs to build the power supply Cord between the BeanDevice[®] and X-solar





List of accessories provided with your X-Solar

- 1 x Solar Panel 20W/50W/80W
MonoCrystalline





X-Solar-7AH product Overview

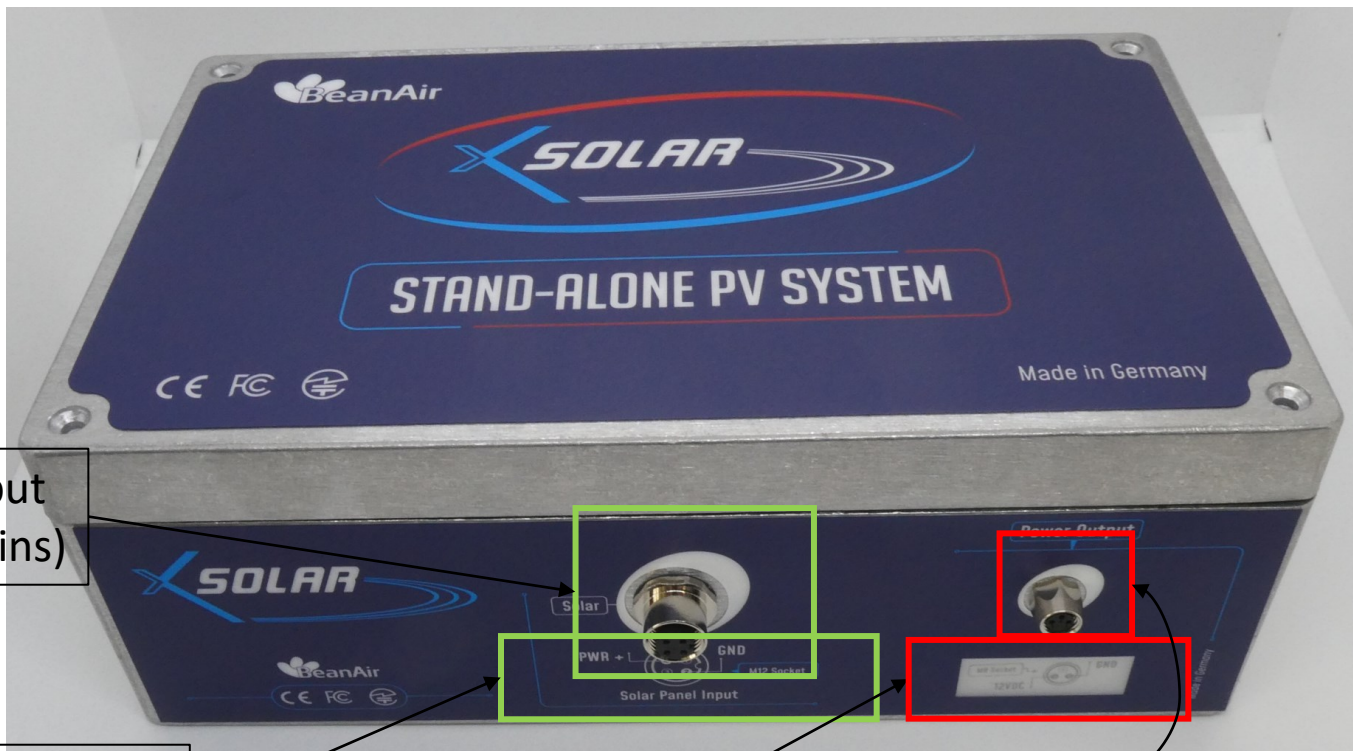

Solar Panel Input
M12 Socket (4Pins)

Solar Panel Input
Wiring code

BeanDevice®
M8 Socket Wiring
code

1xPower supply output For powering BeanDevice®
2.4GHz (4DVDC/12VDC)

4x screws Lock





X-Solar-7AH Socket Wiring Code for 2.4GHZ sensors

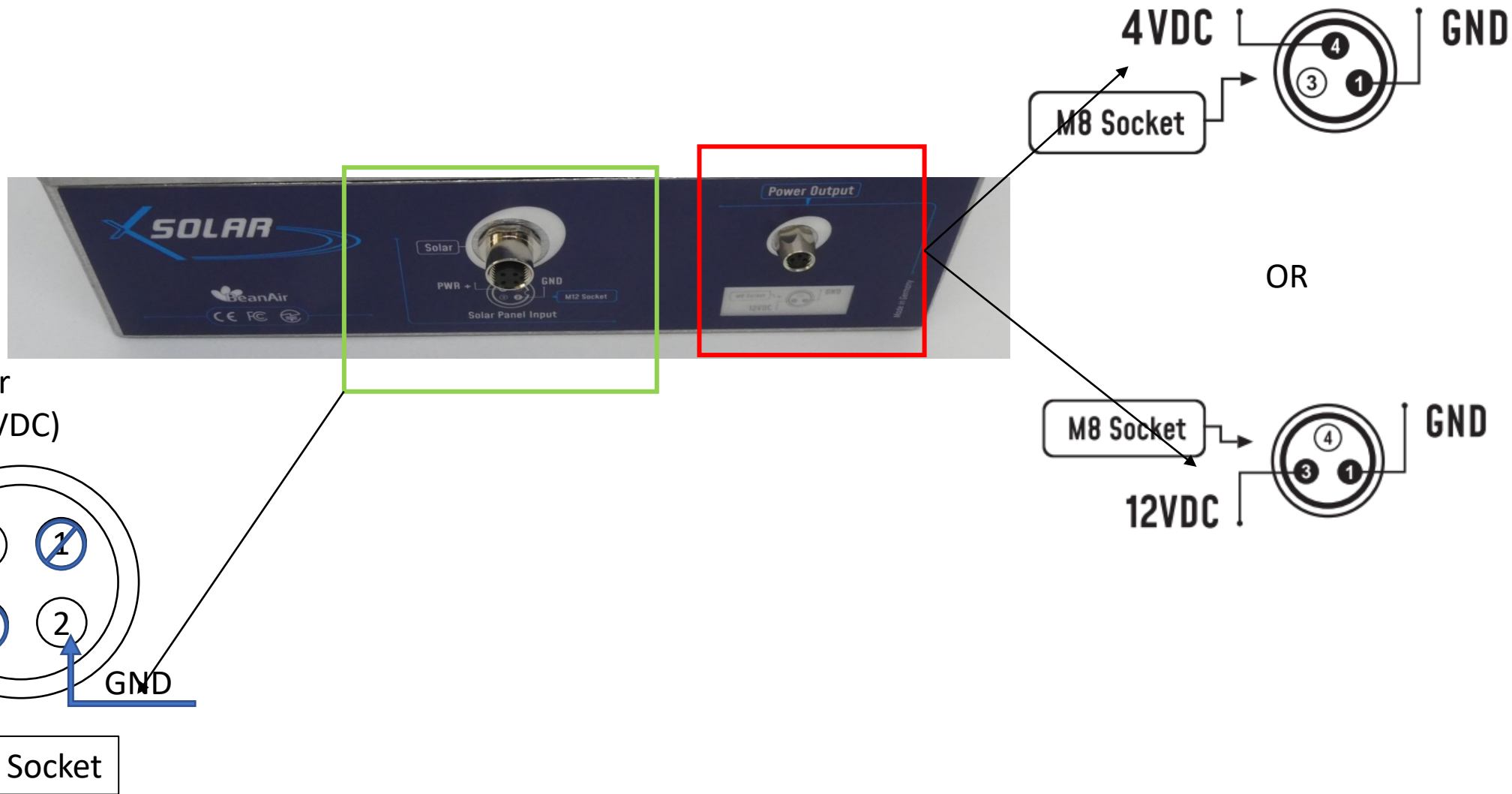



X-Solar-7AH Installation

Once you power supply the X-solar box, open the casing and turn it on by pushing the On/Off button to the left side

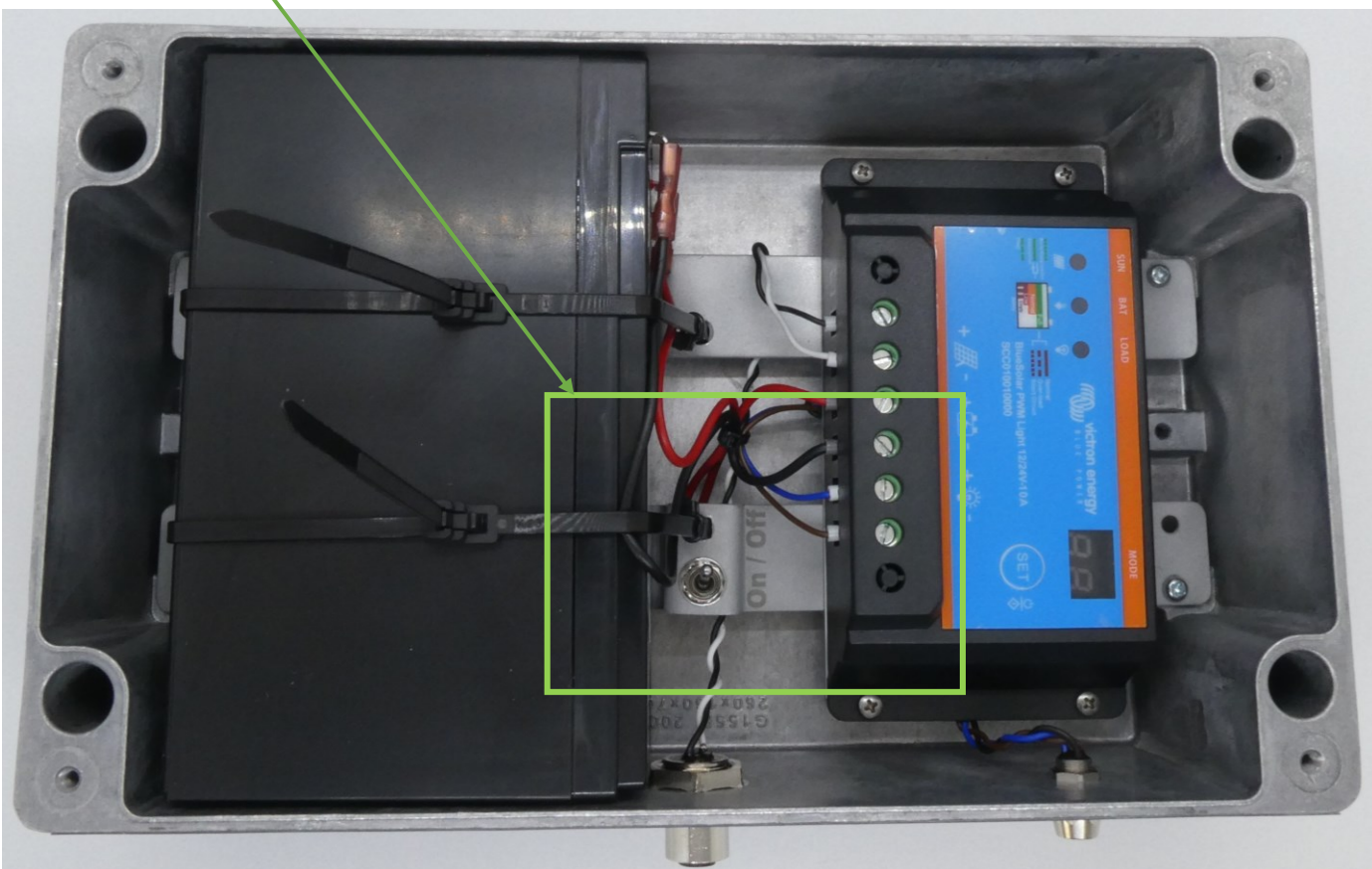

The controller recognize the system voltage and displays 12 for a 12V battery system



If the X-SOLAR is not used, please switch it off to avoid to use power



LED Indicators Description

The X-solar is plugged to the solar panel

Battery is fully charged (>12.7V)

The Load output is ON



Load output controlled by battery voltage only



For Further information, please read the [Victron Bluesolar User Manual](#)



X-Solar-14AH





List of accessories provided with your X-Solar

- 8x M8 Plugs to build the power supply Cord between the BeanDevice[®] and X-solar
- 1 x Solar Panel 20W/50W/80W MonoCrystalline
- X-Solar waterproof Box



X-Solar product Overview



Solar Panel Input
M12 Socket (4Pins)

Solar Panel Input
Wiring code

BeanDevice®
M8 Socket Wiring
code

4xPower supply output For powering BeanDevice®
Wilow® (5VDC) and BeanDevice® 2.4GHz
(4DVDC/12VDC)



Protection Lock

X-Solar-14AH Socket Wiring Code for 2.4GHZ sensors

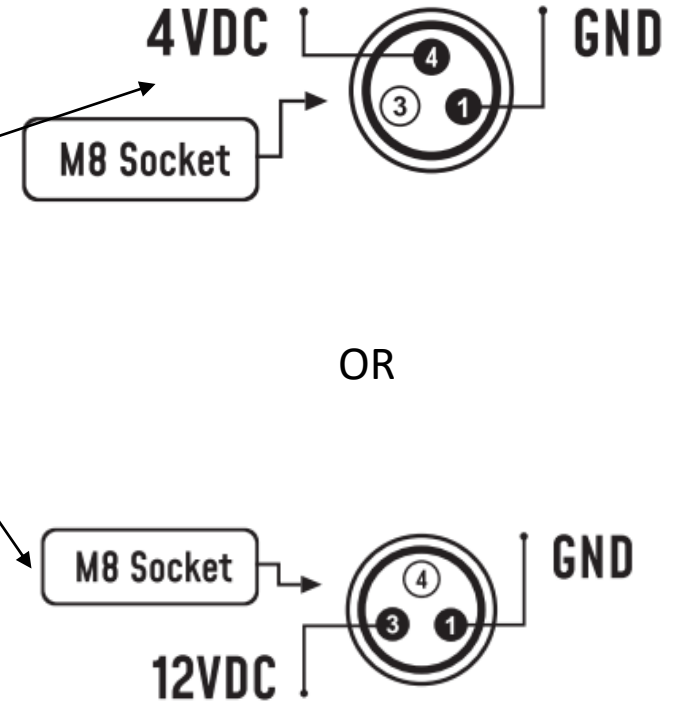
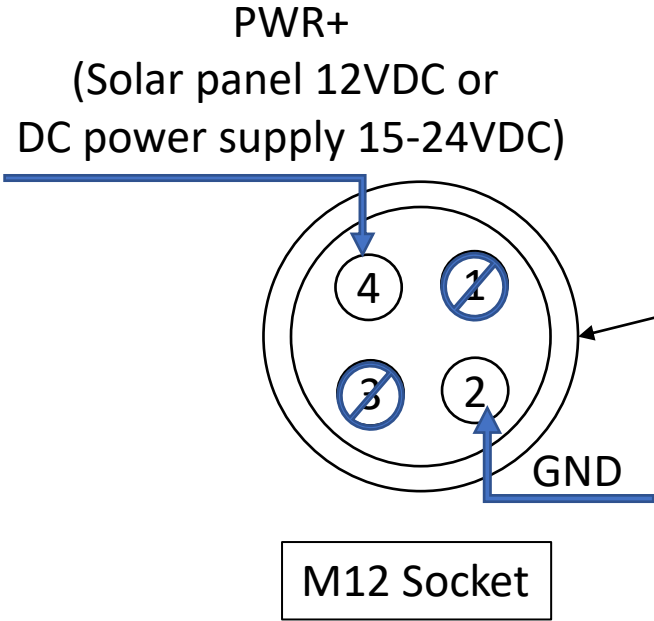



M8 Plug Cable Wiring Code for 2.4GHZ sensors

To build the power supply cord, we provide 8x M8 Plug . The wiring code is the same on both sides (X-solar and BeanDevice®) .

M8 Plug (A –Coding) - Pin Assination (Xsolar with 4VDC Power Output)

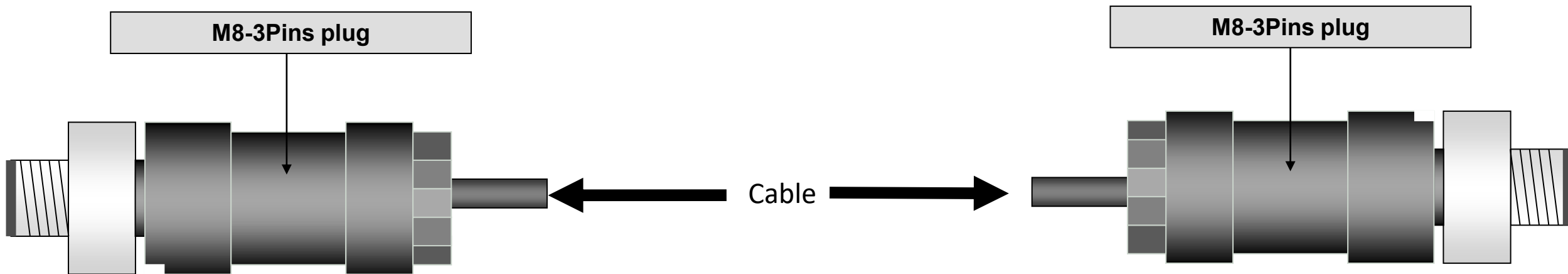

Interface Name	M8 Pin assination
Not used	PIN3
Power Supply 4VDC (available on Xtend version only)	PIN4
Ground	PIN1

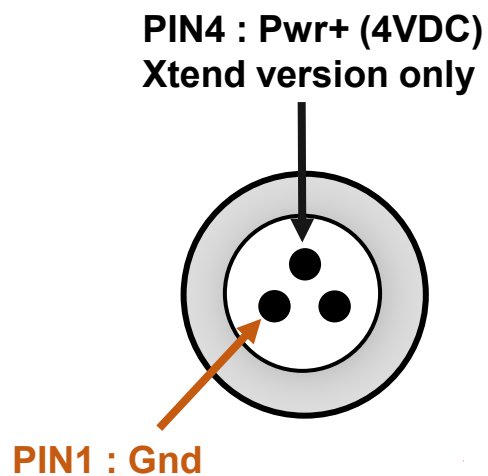



M8 Plug Cable Wiring Code for 2.4GHZ sensors

M8 Plug (A –Coding) - Pin Assigantion (Xsolar with 12VDC Power Output)

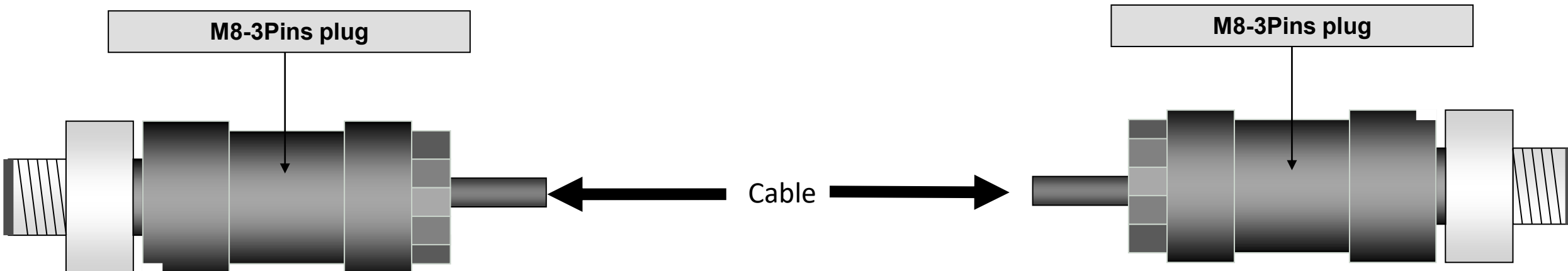

Interface Name	M8 Pin assignation
12VDC Power Output	PIN3
Not used	PIN4
Ground	PIN1

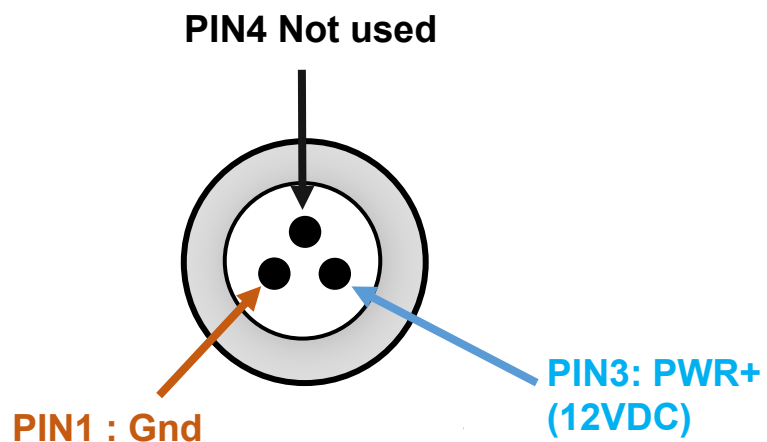



X-Solar-14AH Socket Wiring Code for Wilow sensors



PWR+
(Solar panel 12VDC or
DC power supply 15-24VDC)

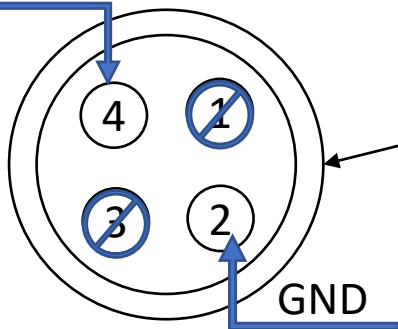

M12 Socket

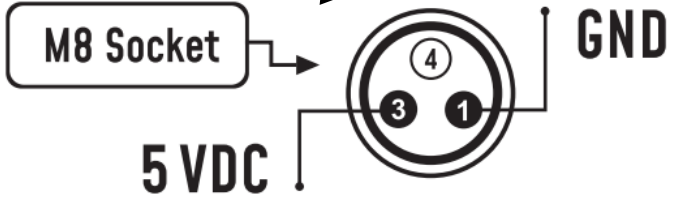

TO BE TESTED

BUL10264



X-Solar-14AH Installation

Once you power supply the X-solar box, open the casing and turn it on by pushing the On/Off button at the bottom left side.

OFF : Switch DOWN

ON : Switch UP



The controller recognize the system voltage and displays 12 for a 12V battery system



If the X-SOLAR is not used, please switch it off to avoid to use power

LED Indicators Description

The X-solar is plugged to the solar panel

Battery is fully charged (>12.7V)

The Load output is ON



Load output controlled by battery voltage only



For Further information, please read the [Victron Bluesolar User Manual](#)



Important Notice about X-solar Power Supply

- You can power supply the X-Solar by using a Solar panel (**nominal voltage 12VDC, Max Voltage 28VDC**) or DC power supply (**nominal voltage 15VDC, Max Voltage 24VDC**)
- Your X-Solar is provided with 20W/50W/80W Monocrystalline Solar Panel
- If you exceed the maximum Voltage, you may damage the Solar Power Controller.
- Reversing the power supply polarity may damage the X-solar and the BeanDevice®
- The X-solar comes with a 14Ah with a protection against the deep discharge.
- The load will be disconnected in case of over discharge when the voltage level is lower than 11.2V
- After over discharge, the load will be reconnected automatically when the battery is recharged to 13.1V
- Power off the X-solar when it's not used.
- Make sure to fully charge the battery before installing the system on site.



Solar Panel Installation and Orientation

- Make sure to install the solar panel on the **rooftop** of the building or the structure where it can **be directly exposed to the sunlight**.
- The performance of the solar panel depends upon the direction in which it's placed, therefore the best direction to face solar panel is **slightly south-west**, since there it can receive the maximum sunlight. In this direction solar panel collects more energy when it face due south and allow the panel to produce more energy in the evening.
- The **solar panel tilt angle** depends on two factors: the **geographical latitude** of your site location and the **season**.
- Further your location is from the equator, the higher your tilt angle should be
- To calculate the **best tilt angle**, **subtract 15deg from the latitude** at your location during **summer** and **add 15deg to your latitude** during **winter**.
- for fixed-mount solar panel, the **solar panel tilt angle** should **be equal to the geographical latitude** at your location for optimal annual energy production.
- The climatic and environmental factors can influence the power output, for example, **snow accumulation** on low-tilt panels can **reduce or completely block the Sun's rays** from reaching the solar panel during the **winter** months.
- In addition, **low-tilt solar panels** are more susceptible to "**soiling**" by **dirt and debris** which can also partially **block the Sun's rays**.



Headquarter :

Beanair GmbH
Wolfener Straße 32 - 34
12681 Berlin - Germany

Middle-East and Africa branch office

Beanair Tunisia
Rue de Kairouan –
4000 Sousse Tunisia

Email: info@beanair.com
www.beanair.com

Stay tuned:



■ <https://www.facebook.com/BeanAir>



■ @beanair



■ Beanair WSN