



## SCIGATE AUTOMATION (S) PTE LTD

No.1 Bukit Batok Street 22 #01-01 Singapore 659592

Tel: (65) 6561 0488

Fax: (65) 6562 0588

Email: [sales@scigate.com.sg](mailto:sales@scigate.com.sg)

Web: [www.scigate.com.sg](http://www.scigate.com.sg)

Business Hours: Monday - Friday 8.30am - 6.15pm

# More Precision

**3D sensors** for precise inline quality control





**GiGE**<sup>®</sup>  
VISION

C/C++

Microsoft  
NET

GEN<i>CAM

Progressive integration and miniaturization in industry require ever smaller manufacturing tolerances. In automated production processes, 100% control is therefore increasingly required in the production line. Non-contact 3D inspection systems from Micro-Epsilon open up numerous application areas here, both for geometric measurements and for surface inspection and defect detection. For example, the flatness of surfaces is important when parts must fit precisely. In addition, the requirements for the appearance of the products are also increasing. More and more high quality materials are being used, and their surfaces must be free of defects.

3D systems from Micro-Epsilon are used for a variety of measurement and inspection tasks on matt and shiny surfaces. The results can be documented and compared. This allows for important conclusions to be drawn for process improvements. All 3D inspection systems from Micro-Epsilon can be used in offline applications as well as in fully automated operation and on the robot.

#### Feasibility study

In order to objectively evaluate your measurement task, we offer inspections of boundary samples. Please feel free to contact us!

---

	<b>surfaceCONTROL 3D 3200</b>	<i>High-performance 3D snapshot sensor for industrial measurement and inspection tasks</i>	<i>Page 4 - 5</i>
	<b>surfaceCONTROL 3D 3500</b>	<i>High precision 3D sensors for inline shape and surface inspections</i>	<i>Page 6 - 7</i>
	<b>surfaceCONTROL 3D 2500</b>	<i>3D sensor for surface and geometry inspection of large objects</i>	<i>Page 8 - 9</i>
	<b>reflectCONTROL Sensor</b>	<i>High resolution 3D inline inspection of reflective surfaces</i>	<i>Page 10 - 11</i>
	<b>scanCONTROL</b>	<i>3D profile scanners for evaluation of profile data and geometry detection</i>	<i>Page 12 - 13</i>
	<b>Software</b>	<i>Powerful 3D software for evaluation, parameter setting and automation</i>	<i>Page 14 - 15</i>

---



- High repeatability up to 0.6  $\mu\text{m}$
- Best z-axis resolution from 1.5  $\mu\text{m}$
- Up to 2.2 million 3D points / second
- Easy integration in all common 3D image processing packets



#### High-performance 3D snapshot sensor for industrial measurement and inspection tasks

The high-performance surfaceCONTROL 3D 3200 snapshot sensor is ideally suited for use in industrial applications. It performs automated inline 3D measurements for geometry, form and surface inspection on diffuse reflecting surfaces. The sensor is characterized by its compact design and high measurement accuracy combined with high data processing speed. With a high z-axis repeatability of up to 0.6  $\mu\text{m}$ , the sensor is ideal for precise 3D measurement and inspection tasks. Two different measuring ranges cover different measuring fields.

In addition to the fast data output via Gigabit Ethernet, the sensor offers an additional digital I/O interface. The 2D/3D Gateway II supports EtherNet/IP, PROFINET and EtherCAT connections. Powerful software tools enable precise 3D measurements and surface inspections. GigE Vision compatibility also allows easy integration into third-party image processing software. The comprehensive SDK for customer software integration rounds off the software package.

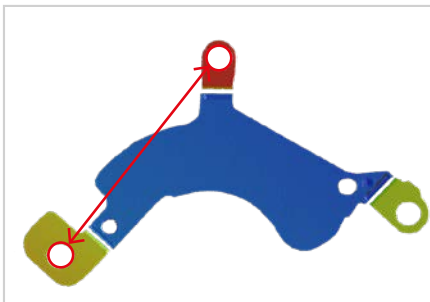

3D measurements of high precision, mechanical parts: distance between the holes, planarity and coplanarity of mounting surfaces

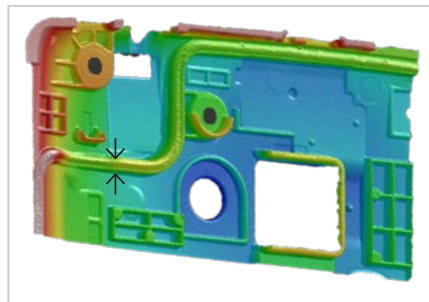

Inspection of height and thickness of adhesive beading on smartphone shells

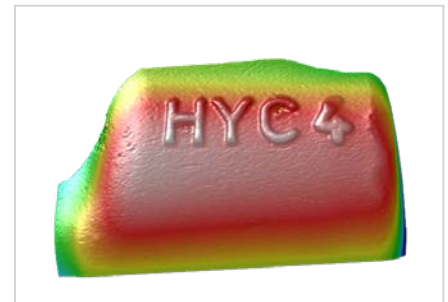

3D text recognition of embossments which cannot be solved with 2D image processing due to lack of contrast

Model	surfaceCONTROL 3D	SC3200-80	SC3210-80	SC3200-120	SC3210-120
Measurement area Length (x) * width (y) at distance (z)	Start of expanded area	50 mm x 44 mm at 110 mm		78 mm x 62 mm at 171 mm	
	Start	65 mm x 47 mm at 120 mm		100 mm x 70 mm at 191 mm	
	Mid	75 mm x 50 mm at 130 mm		115 mm x 75 mm at 206 mm	
	End	74 mm x 53 mm at 140 mm		115 mm x 79 mm at 221 mm	
	End of expanded area	70 mm x 56 mm at 150 mm		113 mm x 85 mm at 241 mm	
Working distance	z	130 ± 10 mm		206 ± 15 mm	
	extended Z	130 ± 20 mm		206 ± 35 mm	
Resolution	x,y	55 ... 70 μm		80 ... 100 μm	
	z <sup>1)</sup>	1.5 μm		3.0 μm	
Repeatability	z (σ) <sup>1)</sup>	< 0.6 μm		< 1.2 μm	
Acquisition time <sup>2) 3)</sup>		0.3 ... 0.7 s			
Light source		LED			
Supply voltage		24 VDC ± 20 %			
Max. current consumption		0.5 ... 1.5 A			
Digital interfaces		Gigabit Ethernet (GigE Vision / GenICam) / PROFINET <sup>4)</sup> / EtherCAT <sup>4)</sup> / EtherNet/IP <sup>4)</sup>			
Digital in-/outputs		4 digital I/Os for which parameters can be set (for external trigger, sensor control, output of sensor states)			
Connection		8-pin M12 socket for Gigabit Ethernet, 12-pin M12 socket for digital I/Os, 4-pin M12 plug for power supply			
Mounting		3 mounting holes (installation can be reproduced with centering sleeves)			
Temperature range	Storage	-20 °C ... +70 °C			
	Operation <sup>5)</sup>	0 °C ... +45 °C			
Shock (DIN EN 60068-2-27)		15 g / 6 ms in XY axis, 1000 shocks each			
Vibration (DIN EN 60068-2-6)		2 g / 20 ... 500 Hz in XY axis, 10 cycles each			
Protection class (DIN EN 60529)		IP67			
Material		aluminum housing, passive cooling; external cooling optionally available (see accessories)			
Weight		1.9 kg			
Control and display elements		3 LEDs (for device status, power, data transmission)			
Sensor SDK		Micro-Epsilon 3D sensor SDK			
3D evaluation software		Micro-Epsilon 3DInspect			
Functional extension		-	3DInspect Automation	-	3DInspect Automation

<sup>1)</sup> Measured on measuring object with cooperative surface in the center of the measurement area while the EnhancedSNR parameter is enabled and a 3x3 mean value filter is used once at a consistent room temperature of (20 ± 1 °C).

<sup>2)</sup> Duration that the sensor requires for the image acquisition of the pattern projections (without processing and evaluation time).

<sup>3)</sup> Applies for exposure times < 6,800 μs

<sup>4)</sup> Connection via 2D/3D gateway interface module

<sup>5)</sup> Max. permissible operating temperature depends on installation scenario, connection and operating mode.

If necessary, external heat dissipation must be implemented to ensure that the sensor's internal temperature of 60 °C is not exceeded.

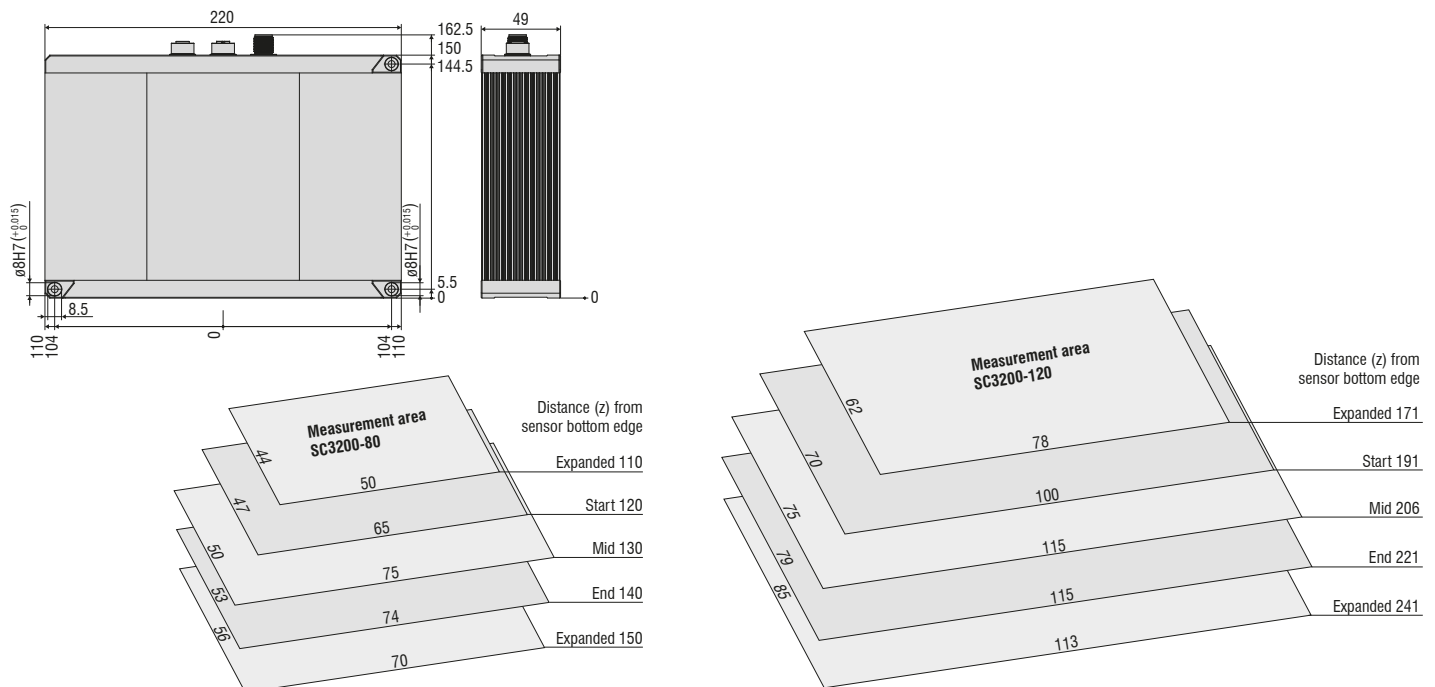



- Highest repeatability up to  $0.4 \mu\text{m}$
- Best z-axis resolution from  $1.0 \mu\text{m}$
- Up to 2.2 million 3D points / second
- Easy integration in all common 3D image processing packets



#### The new generation of high-precision inline 3D measurements

The high precision 3D snapshot sensor surfaceCONTROL 3D 3500 sensor is ideally suited to automated inline inspection of geometry, shapes and surfaces on diffuse reflecting surfaces. The sensor works according to the principle of fringe light projection, which allows direct 3D measurement. The surfaceCONTROL 3D 3500 stands out due to its compact design and high measurement accuracy combined with high data processing speed. With a z-axis repeatability of up to  $0.4 \mu\text{m}$ , the sensor sets new standards in high precision 3D metrology. This enables reliable detection of even the smallest deviations in flatness and height. Two models cover different measuring fields.

In addition to the fast data output via Gigabit Ethernet, the sensor offers an additional digital I/O interface. The 2D/3D Gateway II supports EtherNet/IP, PROFINET and EtherCAT connections. Powerful software tools enable precise 3D measurements and surface inspection. GigE Vision compatibility also allows easy integration into third-party image processing software. The comprehensive SDK for customer software integration rounds off the software package.

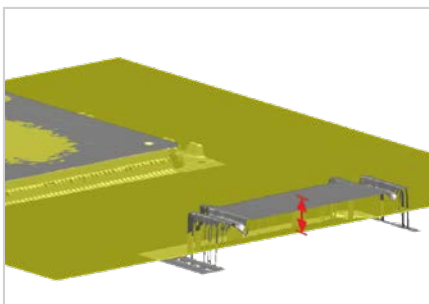

Monitoring of distance and plane-parallelism of assembled elements to each other and to the base surface (e.g. tombstone effect)

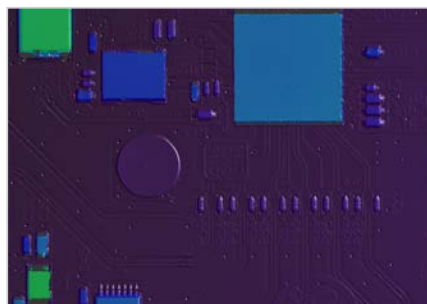

Completeness check of electronic components on fitted PCBs

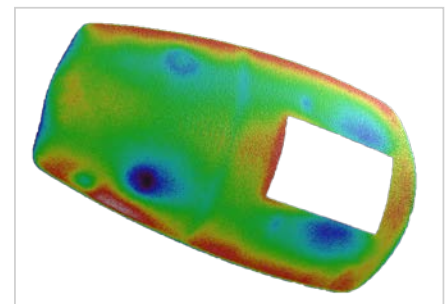

Determination of shape deviation defects on the front side of injection-molded parts caused by injection of bridges and joining elements on the rear side

Model	surfaceCONTROL 3D	SC3500-80	SC3510-80	SC3500-120	SC3510-120
Measurement area Length (x) * width (y) at distance (z)	Start of expanded area	55 mm x 42 mm at 110 mm		87.5 mm x 62.5 mm at 171 mm	
	Start	67.5 mm x 46 mm at 120 mm		107.5 mm x 70 mm at 191 mm	
	Mid	80 mm x 50 mm at 130 mm		120 mm x 75 mm at 206 mm	
	End	77.5 mm x 52 mm at 140 mm		123.5 mm x 80 mm at 221 mm	
	End of expanded area	75 mm x 54 mm at 150 mm		122 mm x 82.5 mm at 241 mm	
Working distance	z	130 ± 10 mm		206 ± 15 mm	
	extended Z	130 ± 20 mm		206 ± 35 mm	
Resolution	x, y	40 μm		60 μm	
	z <sup>1)</sup>	1.0 μm		2.0 μm	
Repeatability	z (σ) <sup>1)</sup>	< 0.4 μm		< 0.8 μm	
Acquisition time <sup>2) 3)</sup>		0.2 ... 0.4 s			
Light source		LED			
Supply voltage		24 VDC ± 20 %			
Max. current consumption		0.5 ... 2.5 A			
Digital interfaces		Gigabit Ethernet (GigE Vision / GenICam) / PROFINET <sup>4)</sup> / EtherCAT <sup>4)</sup> / EtherNet/IP <sup>4)</sup>			
Digital in-/outputs		4 digital I/Os for which parameters can be set (for external trigger, sensor control, output of sensor states)			
Connection		8-pin M12 socket for Gigabit Ethernet, 12-pin M12 socket for digital I/Os, 4-pin M12 plug for power supply			
Mounting		3 mounting holes (installation can be reproduced with centering sleeves)			
Temperature range	Storage	-20 ... +70 °C			
	Operation <sup>5)</sup>	0 ... +45 °C			
Shock (DIN EN 60068-2-27)		15 g / 6 ms in XY axis, 1000 shocks each			
Vibration (DIN EN 60068-2-6)		2 g / 20 ... 500 Hz in XY axis, 10 cycles each			
Protection class (DIN EN 60529)		IP67			
Material		aluminum housing, passive cooling; external cooling optionally available (see accessories)			
Weight		1.9 kg			
Control and display elements		3 LEDs (for device status, power, data transmission)			
Sensor SDK		Micro-Epsilon 3D sensor SDK			
3D evaluation software		Micro-Epsilon 3DInspect			
Functional extension		-	3DInspect Automation	-	3DInspect Automation

<sup>1)</sup> Measured on measuring object with cooperative surface in the center of the measurement area while the EnhancedSNR parameter is enabled and a 3x3 mean value filter is used once at a consistent room temperature of (20 ± 1 °C).

<sup>2)</sup> Duration that the sensor requires for the image acquisition of the pattern projections (without processing and evaluation time).

<sup>3)</sup> Applies for exposure times < 6,800 μs

<sup>4)</sup> Connection via 2D/3D gateway interface module

<sup>5)</sup> Max. permissible operating temperature depends on installation scenario, connection and operating mode.

If necessary, external heat dissipation must be implemented to ensure that the sensor's internal temperature of 60 °C is not exceeded.

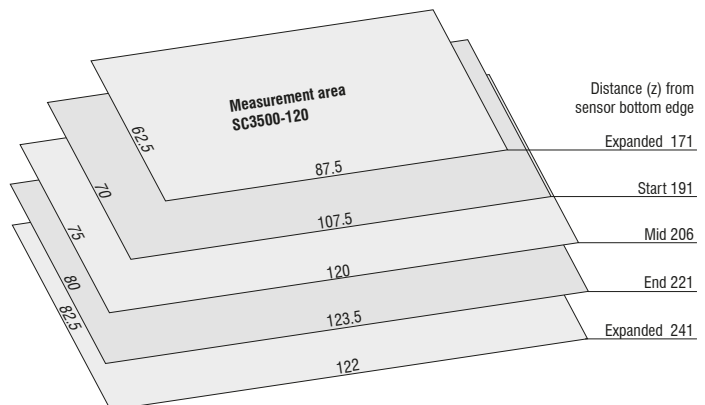
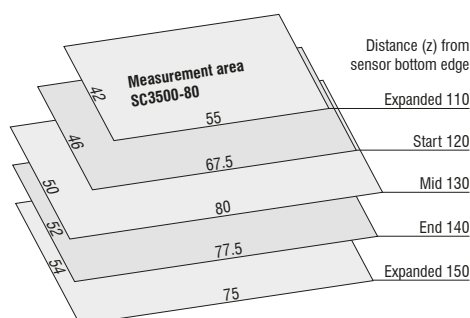
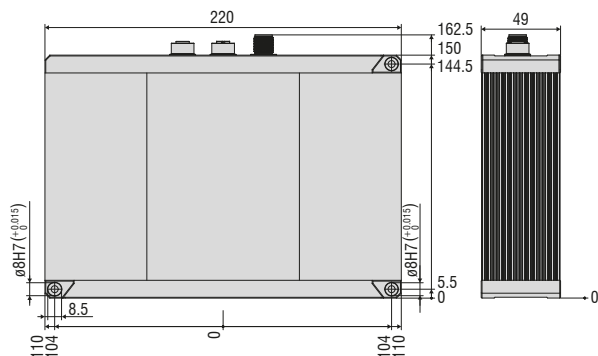



- Inspection of large objects
- High measuring range depth up to 300 mm
- Acquisition time from 0.5 seconds
- Z-axis repeatability up to 3.0  $\mu\text{m}$
- Automated inline 3D measurement for geometry, shape and surface inspections
- Real 3D data via latest 3D GigE Vision standard

#### 3D snapshot sensor for surface inspection of large objects

The surfaceCONTROL 3D sensors are ideally suited to automated inline inspection of geometry, shapes and surfaces on diffuse reflecting surfaces. The 3D snapshot sensors work according to the principle of fringe projection, which allows direct 3D measurement of components. The sensor is characterized by a large measuring field as well as a high measuring range depth with a z-axis repeatability of up to 3.0  $\mu\text{m}$ . Three models cover different measuring fields.

The captured images are first transferred to the external controller where they are processed into 3D data. The SC2500 controller offers fast data output via the Gigabit Ethernet interfaces. The 2D/3D Gateway II supports EtherNet/IP, PROFINET and EtherCAT connections. 3DInspect, DefMap3D and Inspection Tools are powerful software tools that enable precise 3D measurements and surface inspection. GigE Vision compatibility also allows easy integration into third-party image processing software. The comprehensive SDK for customer software integration rounds off the software package.

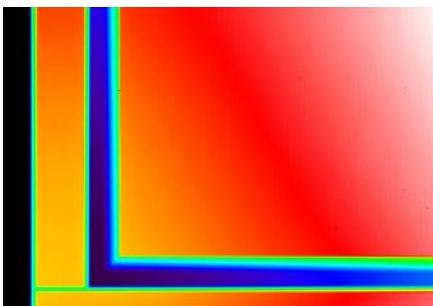

Shape defects on furniture boards

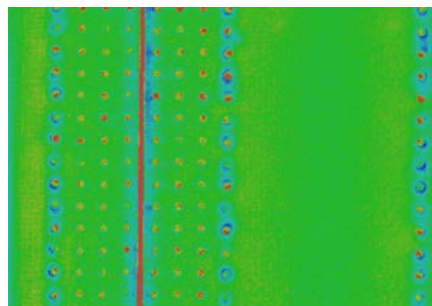

Rivet inspection: deformation, height and position of the rivet

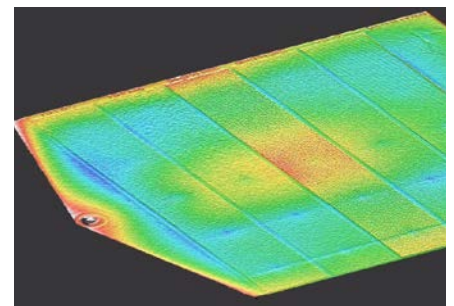

Sink mark on injection molded components



Model	surfaceCONTROL 3D	SC2500-300	SC2510-300	SC2500-400	SC2510-400	SC2500-575	SC2510-575
Measurement area Length (x) * width (y) at distance (z)	Start	260 mm x 190 mm at 475 mm		350 mm x 260 mm at 660 mm		500 mm x 375 mm at 950 mm	
	Mid	300 mm x 220 mm at 550 mm		400 mm x 300 mm at 760 mm		575 mm x 435 mm at 1100 mm	
	End	340 mm x 250 mm at 625 mm		450 mm x 340 mm at 860 mm		650 mm x 495 mm at 1250 mm	
Working distance	z	550 ± 75 mm		760 ± 100 mm		1100 ± 150 mm	
Resolution	x,y	250 μm		300 μm		500 μm	
	z <sup>1)</sup>	8.5 μm		12.7 μm		24 μm	
Repeatability	z <sub>(n)</sub> <sup>1)</sup>	< 3.0 μm		< 4.5 μm		< 8.5 μm	
Acquisition time <sup>2) 3)</sup>				0.5 ... 1 s			
Light source				LED			
Supply voltage				18 VDC ± 33 %			
Max. current consumption				6 ... 12.5 A			
Connection		8-pin M12 socket for Gigabit Ethernet camera 1, connection to controller, 8-pin M12 socket for Gigabit Ethernet camera 2, connection to controller, 4-pin LEMO push-pull plug for sensor control (USB), connection to controller, 2-pin LEMO push-pull plug for supply voltage					
Mounting		Mounting via flange adapter (see accessories)					
Temperature range <sup>4)</sup>	Storage	-10 ... +50 °C, non-condensing					
	Operation	+5 ... +40 °C					
Shock (DIN EN 60068-2-27)		15 g / 6 ms in XY axis, 1000 shocks each					
Vibration (DIN EN 60068-2-6)		2 g / 20 ... 500 Hz in XY axis, 10 cycles each					
Protection class (DIN EN 60529)		IP40					
Material		Carbon, aluminum					
Weight		7.0 kg (without controller)					
Control and display elements		2 LEDs on each camera (for device status, power, data transmission)					
Sensor SDK		Micro-Epsilon 3D Sensor-SDK					
3D evaluation software		Micro-Epsilon 3DInspect					
Functional extension		-	3DInspect Automation	-	3DInspect Automation	-	3DInspect Automation
Surface analysis software	(optional)	surfaceCONTROL DefMap3D					

<sup>1)</sup> Measured on measuring object with cooperative surface in the center of the measurement area while the EnhancedSNR parameter is enabled and a 3x3 mean value filter is used once at a consistent room temperature of (20 ± 1 °C).

<sup>2)</sup> Duration that the sensor requires for the image acquisition of the pattern projections (without processing and evaluation time).

<sup>3)</sup> Applies for exposure times < 25 ms

<sup>4)</sup> According to technical data

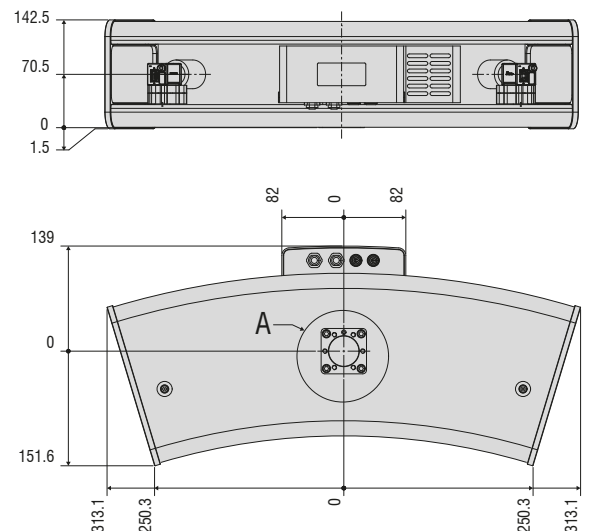
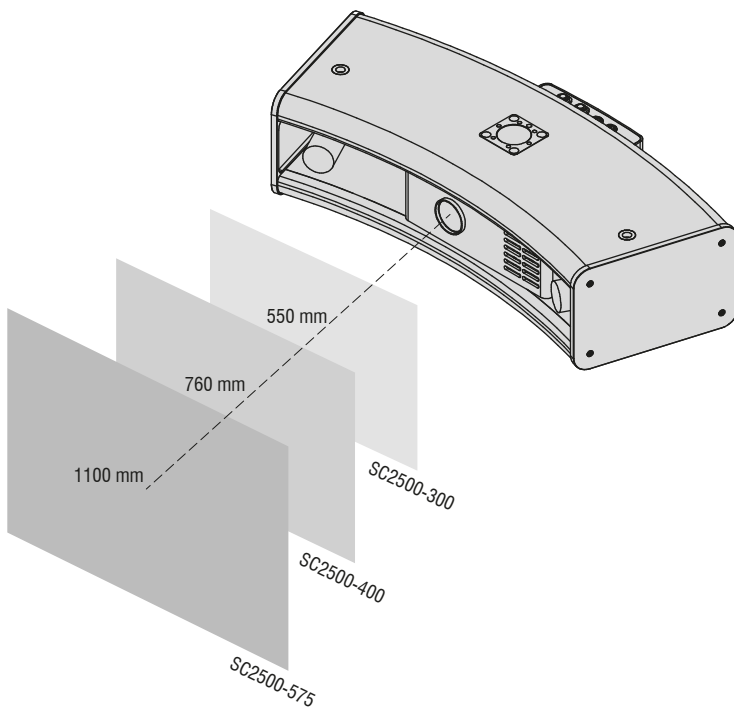



- Reliable detection of the smallest details <math>< 1 \mu\text{m}</math>
- Inspection rate <math>< 2</math> seconds per measuring position
- Stationary or robot-based inspection
- Software integration via Micro-Epsilon's 3D-SDK, based on the industry standards GigE Vision and GenICam

#### Surface inspection of shiny components

reflectCONTROL is intended for surface inspection of shiny objects. This compact sensor displays a striped pattern which is mirrored by the surface of the measuring object into the sensor cameras. Deviations on the surface will cause deviations from this striped pattern, which are evaluated by software.

#### Robot-guided measurement

The compact deflectometry sensor can be integrated as a stationary system or guided over the measuring object by a robot. The localized deviations and defects are evaluated and displayed in CAD data.

#### Application examples:

- Automotive industry: attachments such as bumper and interior parts
- Electronics industry: tablet PCs, display glasses, etc.

### Applications

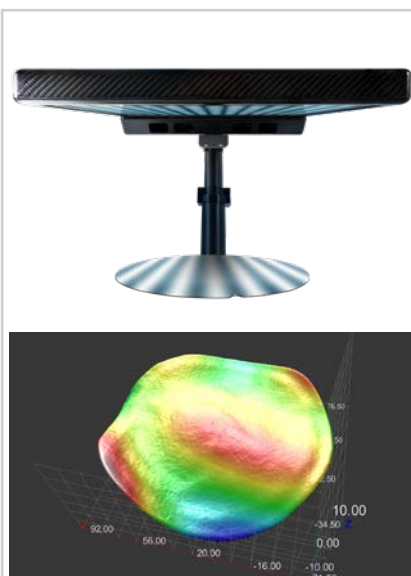

#### 3D shape measurement of wafers

reflectCONTROL sensors exactly detect the wafer's shape in semiconductor production.

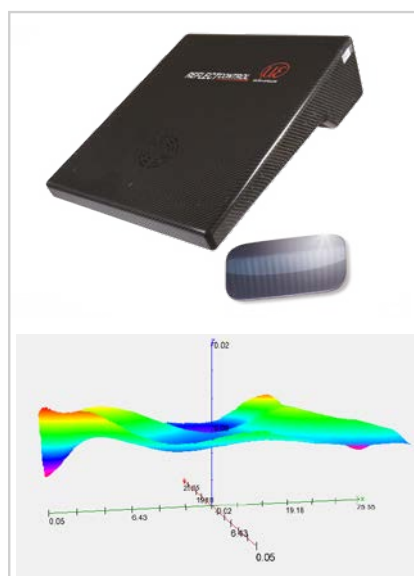

#### Surface inspection of painted attachments

The smallest surface defects below  $1 \mu\text{m}$  are precisely and reliably detected by the reflectCONTROL system.

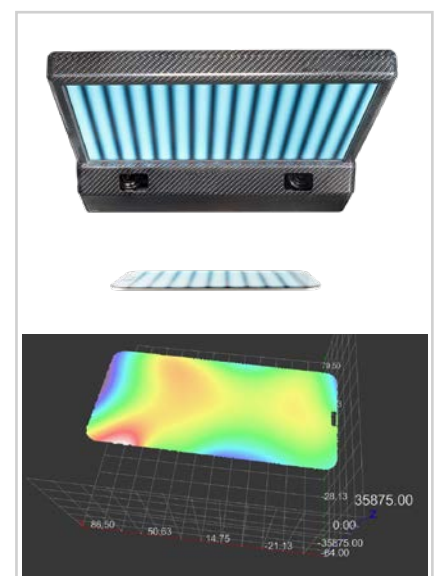

#### Precise inspection of flat glass

The reflectCONTROL system is used for the quality inspection of flat glass, e.g., in smartphone production.

Model		RCS130-160	RCS110-245
Measurement area Length x width (x * y) <sup>1)</sup>	in reference plane	170 mm x 160 mm	116 mm x 245 mm
Acquisition of measurement data		approx. 1.2 s ... 6 s	approx. 0.6 s ... 2.7 s
Evaluation		approx. 2 s ... 8 s	approx. 0.5 s ... 2.4 s
Resolution	x, y	100 μm	70 μm
Flatness deviation	z <sup>2)</sup>	< 1 μm	-
Supply voltage		24 V DC (must not exceed 26 V)	
Power consumption		< 50 W	
Interfaces and connections		1 x GigE Vision (RJ45), 1 x Ethernet (RJ45), power supply (3-pin Lemo connector)	
Mounting		mechanically reproducible adapter flange	
Temperature range	Storage	-10 ... +60 °C	
	Operation <sup>2)</sup>	0 ... +40 °C (for 3D measurements: max. fluctuation of ±2 °C after referencing)	0 ... +40 °C
Humidity <sup>2)</sup>		10 ... 80 %, non-condensing (for 3D measurements: max. fluctuation of ±2 °C after referencing)	10 ... 80 %, non-condensing
Design		carbon housing with controlled fan, design with integrated controller	
Weight		< 7 kg	

<sup>1)</sup> Size specifications refer to the reference plane. Trapezoidal measuring field - the medium width is specified. For exact dimensions see figure.

<sup>2)</sup> Measured after referencing with a plane mirror (ø 300 mm) and a flatness of  $\lambda/10$  at a max. distance tolerance of  $\pm 0.1$  mm.  
After referencing, a maximum temperature fluctuation of  $\pm 2$  °C and change of humidity of  $\pm 2$  % are to be complied with.

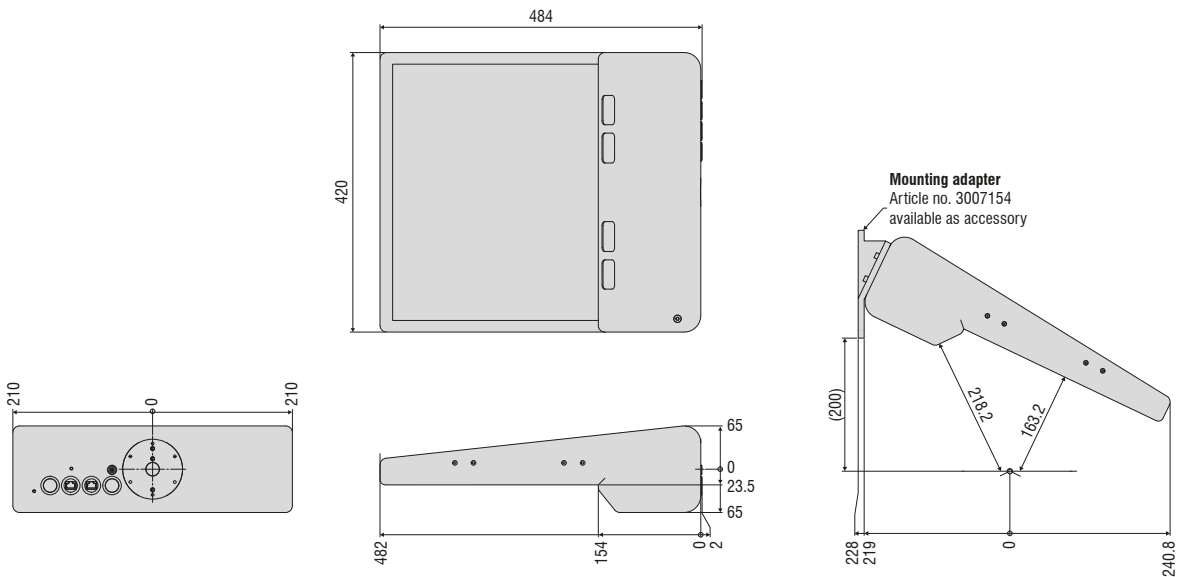

Measuring field RCS130-060

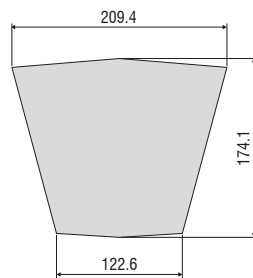

Measuring field RCS110-245

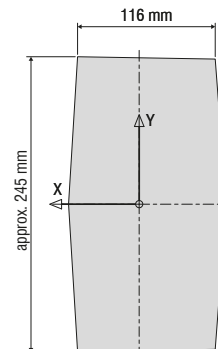

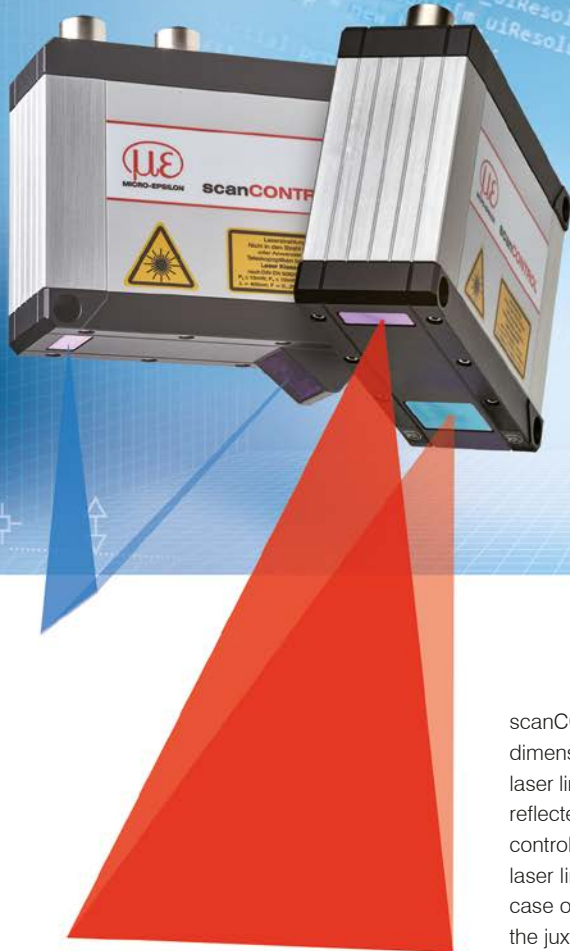

- Up to 2,048 points per profile
- Up to 2,560,000 points per second
- Compact size
- High lateral resolution from 7.8  $\mu\text{m}$
- Small and compact, ideal for robotic applications
- Available with red and blue laser line
- GigE Vision standard - easy to integrate into common image processing software

scanCONTROL laser line scanners use the laser triangulation principle for two-dimensional profile detection on different target surfaces. Line optics project a laser line onto the target surface. A high-quality optical system images the diffusely reflected light from this laser line onto a sensor matrix. From this camera image, the controller calculates the distance information (z-axis) and the position alongside the laser line (x-axis) and outputs both in a two-dimensional coordinate system. In the case of moving objects or traversing the sensor, a 3D point cloud is obtained from the juxtaposition of the profiles.

Assignment of the exact position of the sensor relative to the position of the measured object can be carried out via the integrated encoder inputs. The scanCONTROL laser line scanners have an Ethernet/GigE Vision connection and can therefore be integrated into a wide variety of image processing packages up to 3D evaluation.

A device driver including sample VIs is available for LabVIEW users. Furthermore, integration into Linux is possible.

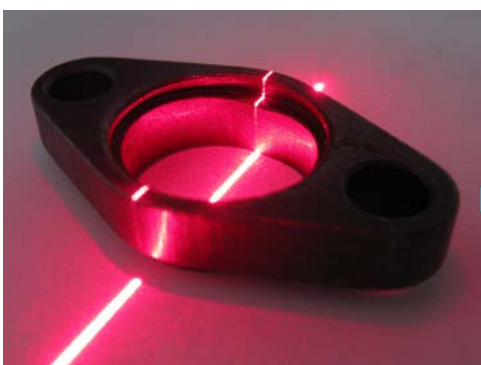

Profile acquisition



Grayscale image

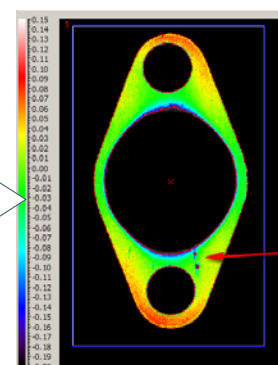

Image processing software

Model		LLT30x0-25	LLT30x0-50	LLT30x0-100	LLT30x0-200	
Available laser type		Red Laser Blue Laser	Red Laser Blue Laser	Red Laser Blue Laser	Red Laser	
z-axis	Measuring range	Start of measuring range	77.5 mm	105 mm	200 mm	200 mm
		Mid of measuring range	85 mm	125 mm	270 mm	310 mm
		End of measuring range	92.5 mm	145 mm	340 mm	420 mm
		Height of measuring range	15 mm	40 mm	140 mm	220 mm
	Extended measuring range	Start of measuring range	-	-	190 mm	160 mm
		End of measuring range	-	-	360 mm	460 mm
	Max. deviation of a single point <sup>1)</sup> (2 sigma)	Red Laser	±0.07 %	±0.07 %	±0.06 %	±0.10 %
		Blue Laser	±0.06 %	±0.06 %	±0.05 %	-
	Line linearity <sup>1) 2)</sup>		1.5 µm	3 µm	9 µm	26 µm
			±0.01 %	±0.0075 %	±0.006 %	±0.012 %
x-axis	Measuring range	Start of measuring range	23.0 mm	43.3 mm	75.6 mm	130 mm
		Mid of measuring range	25.0 mm	50.0 mm	100 mm	200 mm
		End of measuring range	26.8 mm	56.5 mm	124.4 mm	270 mm
	Extended measuring range	Start of measuring range	-	-	72.1 mm	100 mm
		End of measuring range	-	-	131.1 mm	290 mm
	Resolution		2,048 points/profile			
Profile frequency		up to 10,000 Hz				
Interfaces	Ethernet GigE Vision	Sensor control Profile data transmission				
	digital inputs	Mode switching Encoder (counter) Trigger				
	RS422 (half-duplex) <sup>3)</sup>	Sensor control Trigger Synchronization				

<sup>1)</sup> Based on the measuring range; measuring object: Micro-Epsilon standard object

<sup>2)</sup> According to a one-time averaging over the measuring field (2,048 points)

<sup>3)</sup> RS422 interface, programmable either as serial interface or as input for triggering/synchronization

<sup>4)</sup> Only with 2D/3D Output Unit

<sup>5)</sup> Only with 2D/3D Gateway

### Software integration via Micro-Epsilon's 3D-SDK

scanCONTROL is equipped with a convenient SDK (Software Development Kit). The SDK is based on the GigE Vision and GenICam industry standards including the following essential function blocks:

- Network configuration and sensor connection
- Control of data transmission (3D measurement data, video images, profile counters, ...)
- Comprehensive sensor control
- User sets
- Documentation
- C++ example programs
- 3D Viewer

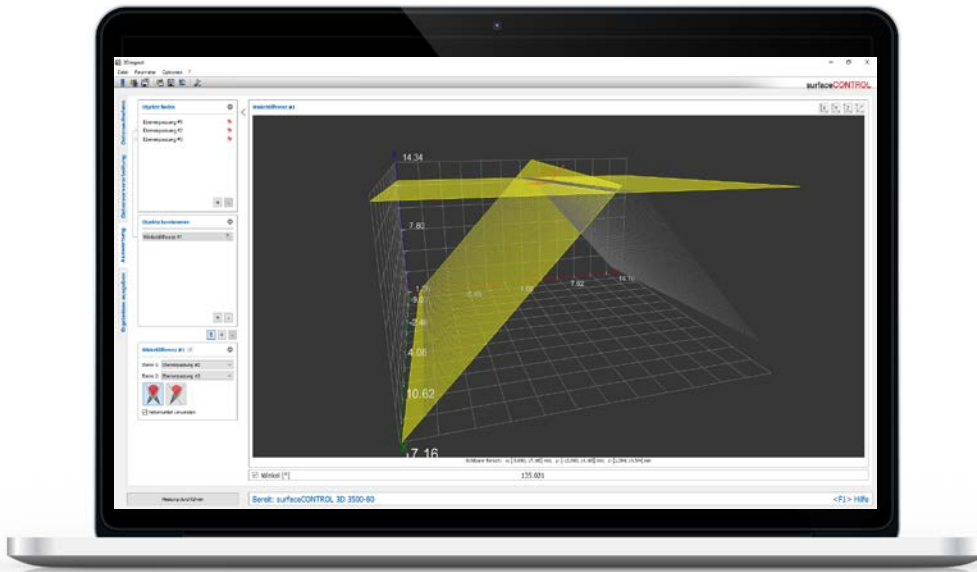

### 3D-Inspect at a glance:

- One software for all 3D sensors
- High compatibility
- High flexibility
- Intuitive user interface
- Real 3D evaluation, not just 2.5D
- Object extraction in 3D
- Direct feedback with algorithms

### 3DInspect software for 3D measurement and inspection tasks

The 3DInspect software is a powerful tool for sensor parameter set up and industrial measurement tasks. This software transmits the measurement data from the sensor via Ethernet and provides the data in three-dimensional form. This 3D data is further processed, evaluated and assessed with 3DInspect measuring programs on the PC and, if necessary, logged and transmitted via Ethernet to a control unit. Furthermore, the software enables the storage of 3D data. The 3DInspect software is included. For connection to an automation interface, the 3DInspect Automation function extension is enabled with use of the SC3510 sensors, which also includes comprehensive data logging.

### Valid3D: Real 3D without data loss

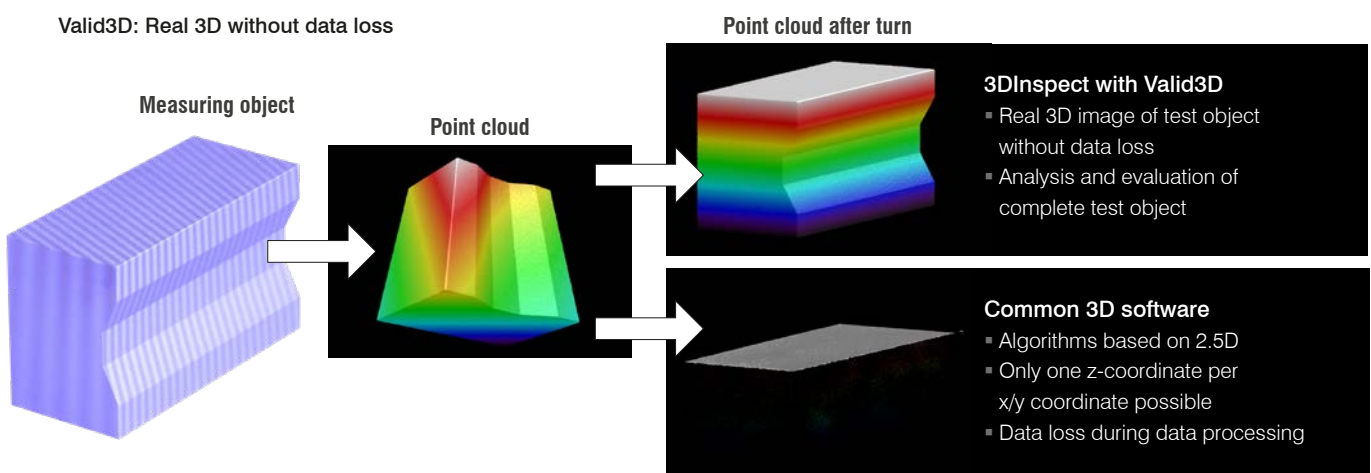

### 3D-View software for 3D visualization

The 3D-View software offers a convenient user interface for surfaceCONTROL sensors. This user-friendly software enables quick commissioning and evaluation of the sensor. It offers set up and optimization of parameters and ensures the correct positioning of the measuring object and sensor. The software can also be used to start data acquisition. It visualizes the 3D data obtained and exports it in different file formats (ASCII, CSV, STL, PLY) for further processing.

The 3D-View software is particularly helpful for system integrators as it provides important information. They can access all GenICam parameters, which considerably simplifies the integration of the software. For inline applications, the display of the measurement duration allows conclusions to be drawn about the cycle time.

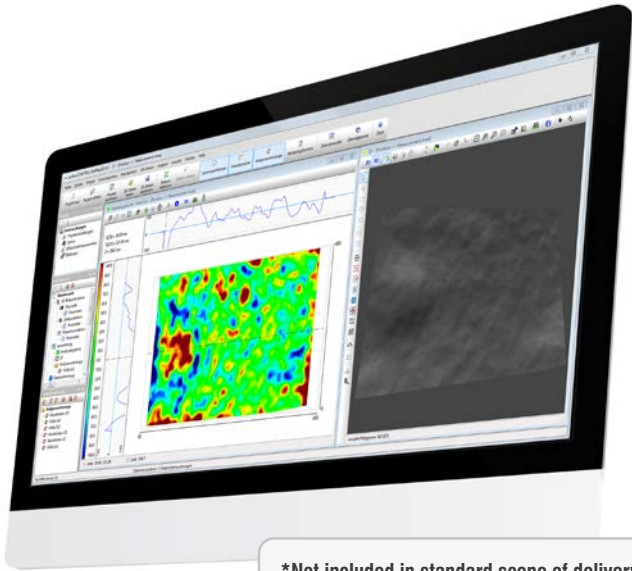

\*Not included in standard scope of delivery

### surfaceCONTROL DefMap3D for individual surface analysis\*

surfaceCONTROL DefMap3D is a comprehensive software solution for the detection and analysis of surface defects. It includes all components and processes required for set up, configuration and evaluation of inspection tasks.

The wide range of features equally supports the analysis of individual parts, the measurement of small series as well as the robot-supported inspection of several measuring fields. Sensor control, calculation of the 3D point cloud and defect detection can be automated using macro commands.

As part of the surface analysis, the software provides several methods of detecting and objectively evaluating shape errors within the surface data. The targeted use of different filter types can reduce the effects of surface structures (e.g. graining). A report containing the inspection results is generated. surfaceCONTROL DefMap3D is available in different versions whose scope of performance is oriented towards different measurement tasks.

#### Digital Shape

The 3D data of the surface is described using polynomials. Depending on their degree, the polynomials have the ability to adapt the shape of the surface like an envelope. The 3D data is compared against the calculated envelope and possible deviations in the surface are identified as defects.

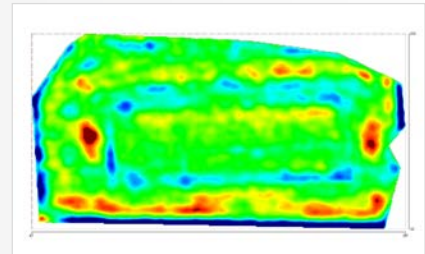

#### Digital Stone

With the 3D data, you can determine the two highest points (point of support) along a line segment in a given direction. Afterwards the gaps between this line and the 3D data are calculated.

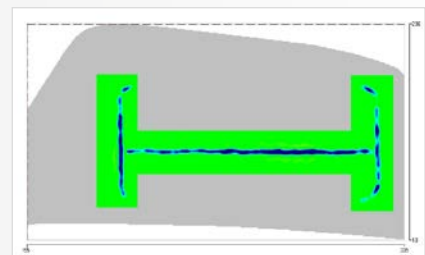

#### Digital Light Tunnel

The captured 3D data is given defined properties (color, gloss) and optionally reflected on the screen with a diffuse light or a light bar. This is how even the smallest defects become visible and can be assessed visually.



## Sensors and Systems from Micro-Epsilon



Sensors and systems for displacement, position and dimension



Sensors and measurement devices for non-contact temperature measurement



Measuring and inspection systems for quality assurance



Optical micrometers, fiber optics, measuring and test amplifiers



Color recognition sensors, LED Analyzers and inline color spectrometers



3D measurement technology for dimensional testing and surface inspection