



SCIGATE AUTOMATION (S) PTE LTD

Bukit Batok Street 22 #01-01 Singapore 659592

Tel: (65) 6561 0488

Fax: (65) 6561 0588

Email: sales@scigate.com.sg

Web: <https://scigate.com.sg/>

Business Hours: Monday - Friday 8:30AM - 6:15PM

More Precision

mainSENSOR // Magneto-inductive displacement sensors

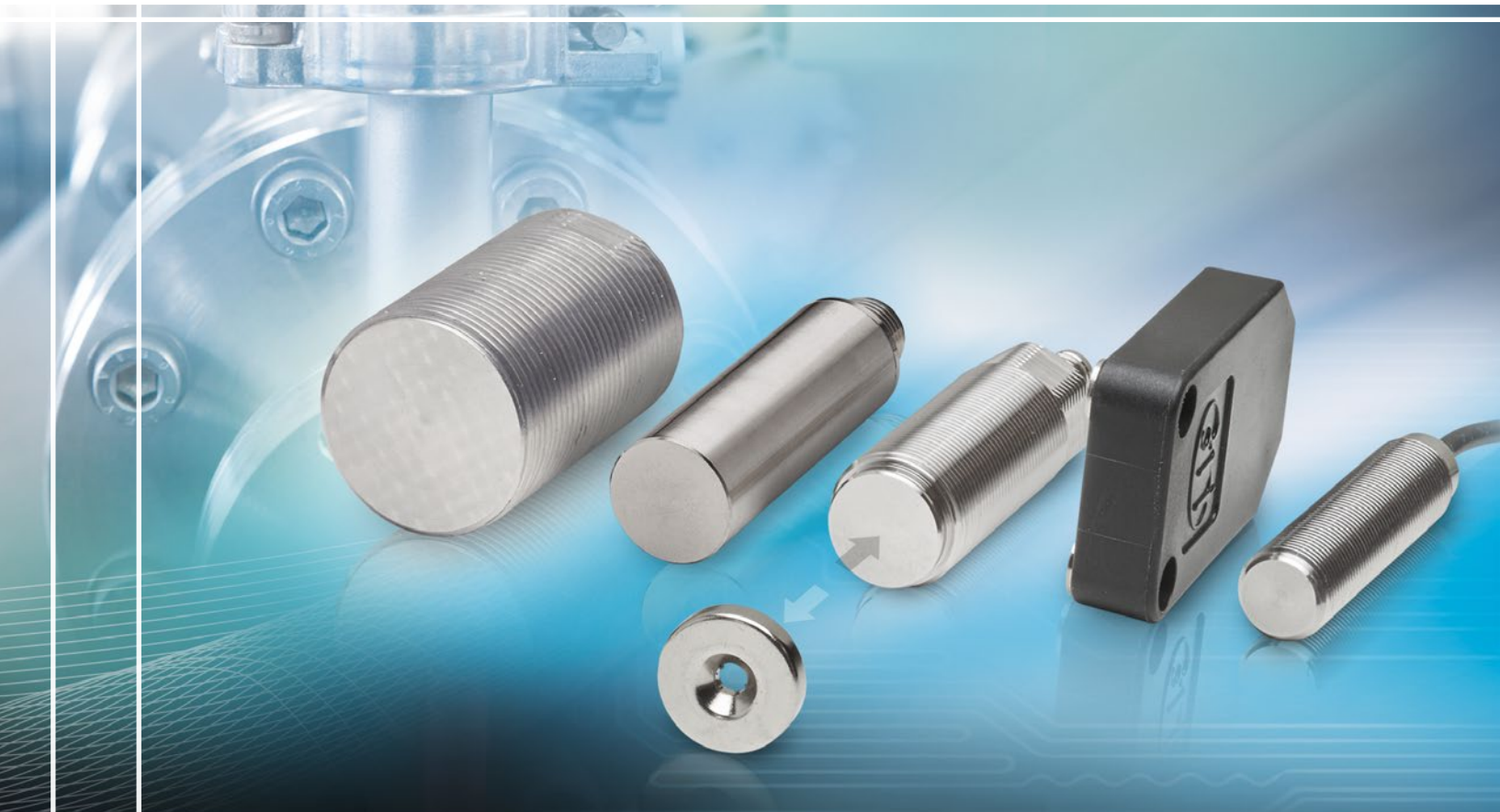



- *Selectable measuring ranges up to 55 mm*
- *Linear output signal*
- *High basic sensitivity and temperature stability*
- *Non-contact and wear-free operation*
- *High dynamics*
- *Available in any quantity*

Measuring principle

mainSENSOR is based on an innovative measuring principle, which has been developed by Micro-Epsilon in order to combine the advantages of both inductive and magnetic sensors.

A magnet is fixed to the measurement object. The movement of the magnet induces a change in the magnetic flow in the sensor element, which is detected by the sensor coil. A linear relationship between output signal and magnet distance (self-linearization technology) is produced due to counteracting physical effects. As different strength magnets are applied, measuring ranges of up to 55 mm can be achieved. However, for changing the measuring range, it is only necessary to change the magnet. As well as for displacement and distance measurements, these sensors are also used in special applications such as rotational speed measurement of e.g. shafts and gear wheels.

Flexibility

The flexible concept makes the sensors suitable for the application in different fields of application especially in case of high quantities. The standard sensors are designed with an industrial-grade M12, M18 or M30 stainless steel housing or with a flat plastic housing. The integrated evaluation electronics is situated on a compact PCB. In high volume production, customer-specific modifications to the PCB and sensor housing can be implemented at low cost.

No calibration required

The automatic sensor linearization ensures a linear sensor signal. Therefore, no calibration is required which makes the installation of multiple sensors incredibly simple. Before starting the operation, only the zero point has to be set by positioning the sensor and the magnet. Consequently, the sensors are ready for use within a short time.

Robustness

- Stainless steel housing (insensitive to dirt, oil, etc.)
- Protection classes up to IP67 and IP69K
- Pressure resistance
- Food grade



Automation, machine building and OEM applications

Magneto-inductive sensors from Micro-Epsilon have many potential areas of use, including individual applications in conventional machine building to measurements in automated processes and cost-sensitive high volume production.



Picture: Uhlmann Pac-Systeme GmbH & Co. KG

Foreign body detection in medical technology

In this application, the MDS sensor recognizes foreign bodies in blister machines during the tablet packaging process. Via the movement of overhead touching rollers, foreign bodies between the blister packaging and covering material can be detected. Exceeding a pre-defined point triggers an alarm.



Picture: SIG Combibloc Group AG

Valve lift measurement in the food industry

During the filling of drinks cartons, the exact dosage is a critical factor. The sensor measures the valve lift of the filling line and requests several switching points in a measuring range of 35mm. The sealed stainless steel housings of the MDS-45-Mxx series are ideal for the food industry.



Rotational speed measurement in marine diesel

Integrating the magnet into the sensor housing (magnetic bias) enables the detection of large ferromagnetic particles. This effect is useful for measuring the rotational speed of gear wheels in marine diesel engines. This special arrangement can be found in one of the customer-specific sensors.



Imbalance and load detection in washing machines

Integrating displacement measurement into the washing machine damper helps to detect the imbalance and the loading of the drum. This measurement is performed using the cost-effective MDS-40-LP series sensor. A conventional hard ferrite magnet is integrated into the damper while the sensor board can later be clipped on from the outside.

Installation

Unlike inductive sensors, Micro-Epsilon's magneto-inductive sensors offer versatile installation possibilities. The sensor can be immersed in non-ferromagnetic objects, flush mounted or protruding without influencing the measurement accuracy. The magnet is mounted to the measurement object using a stainless steel screw, which is supplied with the sensor.



Measuring through non-ferromagnetic materials

Unlike conventional measuring procedures, the magneto-inductive sensor also measures through non-ferromagnetic materials such as aluminum and steel. A clear benefit is provided here as the sensor and the magnet can be installed separately in applications with closed systems or housings. It is therefore possible to mount the magnet safely in harsh environments and the sensor in protected areas.

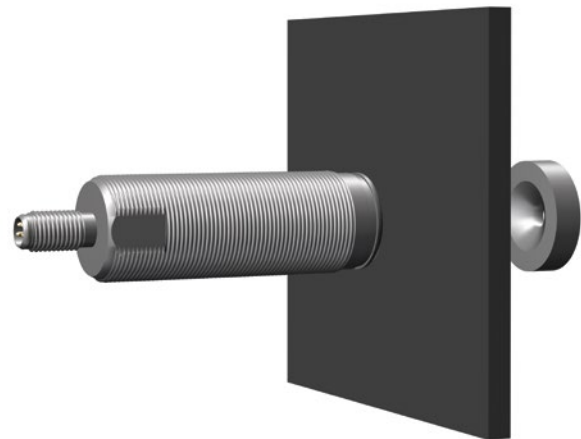

Axial and side-shifted distance and displacement measurements

mainSENSOR detects the position of a magnet, which is fixed to the measurement object. The magnet can be applied to the sensor either axially or side on. Due to the flat design of the sensor element, a magnet

offset of a few millimeters do not influence the characteristic curve. Larger offsets influence the signal (linearity and gradient). Especially in the case of restricted installation spaces, side shifted measurement offers a space saving alternative.

Axial measurement direction

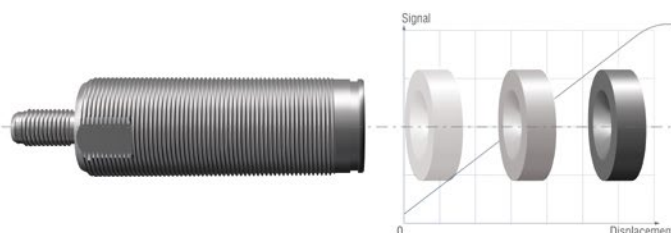

Side shifted measurement direction

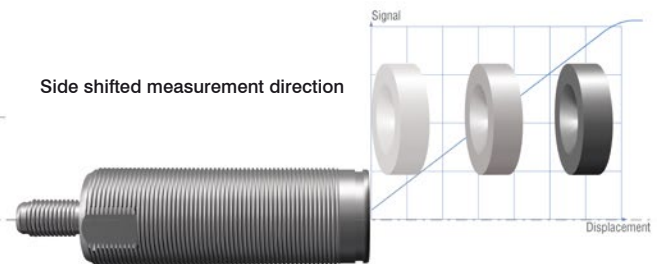

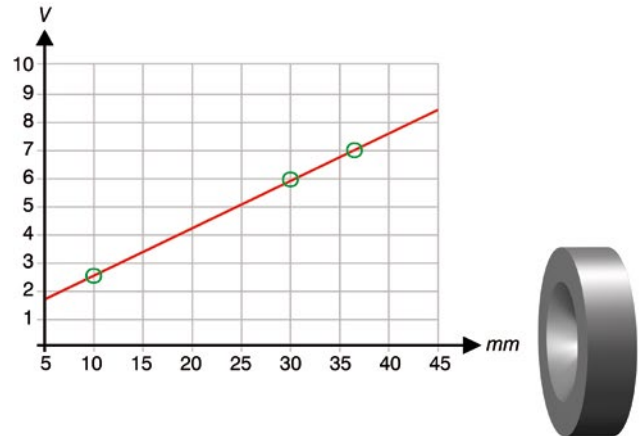

Advantages over inductive sensors

- Constantly high sensitivity, even at the end of measuring range
- High protection class (solid metal housing)
- Compact design with large measuring range (e.g. M12 at 55 mm measuring range)
- Flush installation in non-magnetic materials
- Measurements on electrically conductive and non-magnetic materials (stainless steel, aluminum...)
- Excellent linearity

Ideal alternative to switches and proximity sensors

Magneto-inductive sensors are the preferred alternative to switching elements. The user can generate as many switching points as desired from the continuous analog signal.

- No complex, mechanical adjustments are required for setting the switching point
- Definition of almost any number of switching points
- One sensor model suitable for many different distances

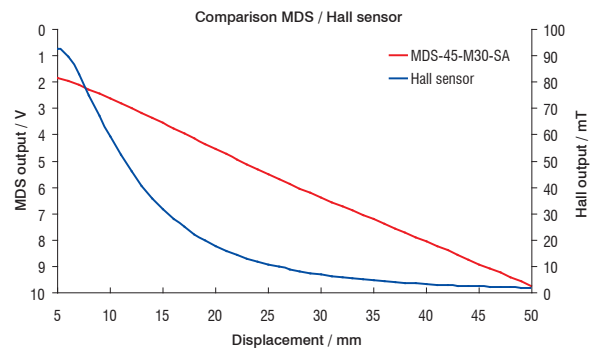
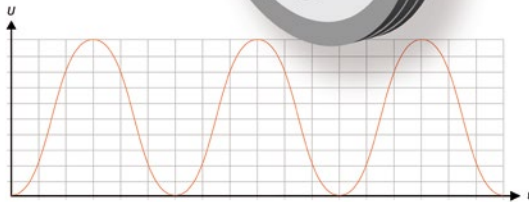

Rotational speed measurement

In addition to displacement and distance measurements, mainSENSOR can also be used to measure rotational speed. In order to do this, one or two magnets are mounted on the rotating measurement object. Regardless of the direction of rotation, the sensor measures the speed of the target object. In addition, customer-specific models are able to recognize the direction of rotation. Therefore, two sensor components that detect and evaluate the direction of the signal increase are installed.

Advantages over magnetic sensors based on Hall Effect components

- Significantly extended measuring range
- Continuous output signal is linear to the distance
- Significant price advantages with large measuring ranges
- Signal stability when magnet is not centered



MDS-45 is the industry-standard version of the magneto-inductive sensor. These stand out due to the common characteristics of this product series and also because of their very robust standard housing.

They are available in M18 and M30 stainless steel housings, as well as with a flat plastic housing. The stainless steel housing is ideally suited to demanding environments (dirt, oil, chemicals) and the food industry.

MDS-45-M18-SA / MDS-45-M18-HP-SA

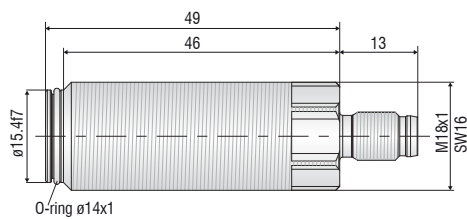

MDS-45-M30-SA

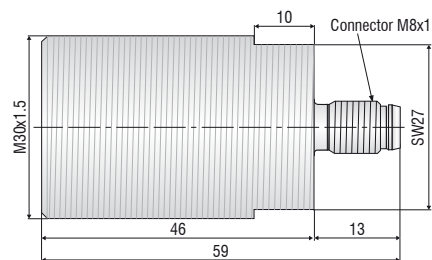

MDS-45-M18-SA (01)

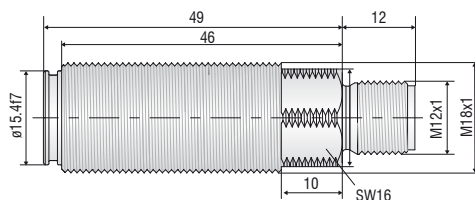

MDS-45-K-SA

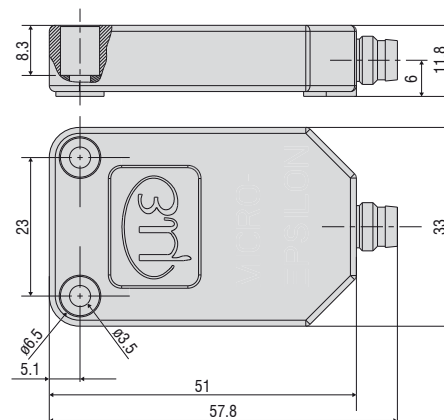

(Dimensions in mm, not to scale)

| Model | MDS-45-M18-SA | MDS-45-M18-SA(01) | MDS-45-M18-HP-SA | MDS-45-M30-SA | MDS-45-K-SA |
|----------------------------------------|---------------------------------------------------------------------------|----------------------------------------------------------------------------|---------------------------------------------------------------------------|-------------------------------|--------------------------------|
| Measuring range ¹⁾ | 45 mm (for other measuring ranges see page 18) | | | | |
| Magnet included in delivery | MB45 | - | MB45 | MB45 | MB45 |
| Start of measuring range ¹⁾ | 2.25 mm | | | 4 mm | |
| Resolution ³⁾ | Voltage | 0.05 % FSO | | 0.05 % FSO | |
| | Current | - | | 0.2 % FSO | |
| Linearity ¹⁾²⁾ | ≤ ±3% FSO | | | | |
| Repeatability | ≤ ± 0.05 % FSO | | | | |
| Frequency response (-3dB) | 3000 Hz | | | 1000 Hz | |
| Temperature stability | ≤ 250 ppm FSO/K | | | | |
| Supply voltage | 11.5 ... 30 VDC | | | | |
| Max. current consumption | 20 mA (with voltage output); 40 mA (with current output) | | | | |
| Analog output | Voltage | 2 ±0.3 ... 9.6 ±0.4 V | | 2 ±0.2 ... 9.6 ±0.4 V | 2 ±0.4 ... 9.6 ±0.4 V |
| | Current | - | | 4 ±0.4 mA ... 19.2 ±0.8 mA | 4 ±0.8 mA ... 19.2 ±0.8 mA |
| Connection | Supply/signal: screw/plug connection 4-pin M8; axial output ⁵⁾ | Supply/signal: screw/plug connection 4-pin M12; axial output ⁵⁾ | Supply/signal: screw/plug connection 4-pin M8; axial output ⁵⁾ | | |
| Mounting | Thread M18x1 | | | Thread M30x1.5 | Through bores |
| Temperature range | Storage | -20 ... +80 °C | | | |
| | Operation | -20 ... +80 °C | | | |
| Pressure resistance | 100 bar (front) | 400 bar (front) | 40 bar (front) | - | |
| Shock (DIN-EN 60068-2-27) | 40 g / 6 ms, 1000 shocks ; 100 g / 6 ms, 3 shocks | | | | |
| Vibration (DIN EN 60068-2-6) | 10 ... 58 Hz ±1.5 mm / 58 ... 500 Hz ±20 g per axis, 10 cycles | | | | |
| Protection class (DIN-EN 60529) | IP67 ⁴⁾ ; higher protection class available on request | | | | |
| Material | Stainless steel | | | | Plastics / nickel-plated brass |
| Weight | approx. 40 g | | | approx. 110 g | approx. 25 g |
| Features | - | - | Seawater resistant | - | - |

FSO = Full Scale Output

¹⁾ Measuring range changes by using other magnets (see catalog p.18); external magnetic fields and/or ferromagnetic material in the measuring range of the sensor system affect the sensor characteristic line and the technical data.

²⁾ Deviation to the regression curve according to the method of least squares

³⁾ Peak-Peak; external first-order low pass; frequency response 5 kHz

⁴⁾ For plug versions only in plugged and screwed condition

⁵⁾ Connection cable see accessories

Sensor signal

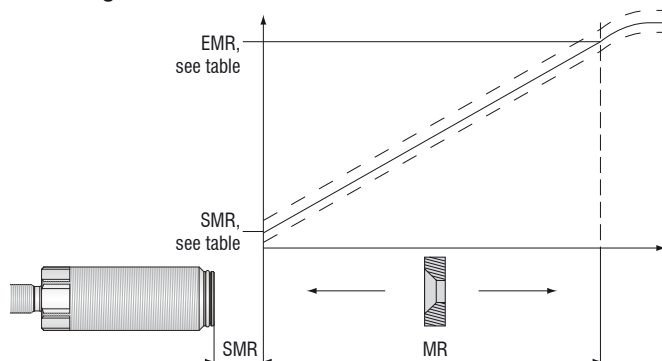

| MDS-45 | SMR | | EMR |
|-------------|--------------------------|---------|---------------------------------|
| -M18-SA | 2V ±0.3V | 2.25 mm | 9.6 V ±0.4 V |
| -M18-SA(01) | 2V ±0.3V | 2.25 mm | 9.6 V ±0.4 V |
| -M18-HP-SA | 2V ±0.3V | 2.25 mm | 9.6 V ±0.4 V |
| -M30-SA | 4 mA ±0.4 mA 2V ±0.2V | 4 mm | 19.2 mA ±0.8 mA 9.6 V ±0.4 V |
| -K-SA | 4 mA ±0.8 mA 2V ±0.4V | 9.1 mm* | 19.2 mA ±0.8 mA 9.6 V ±0.4 V |

* relates to center of the mounting hole

MR = Measuring range, SMR = Start of measuring range, EMR = End of measuring range



Magneto-inductive M12 sensors are industrial-grade models for restricted installation spaces. Designed for use in harsh environments and high temperatures up to 120 °C, these sensors are available either with connector or integrated cable. MDS-M12 sensors are ideally suitable for applications in demanding, industrial environments.

MDS-45-M12-CA

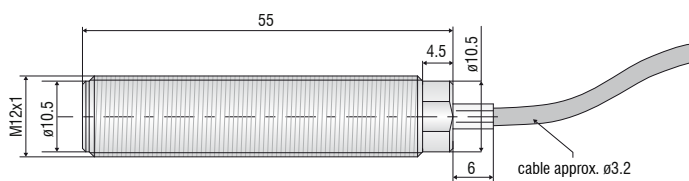

MDS-45-M12-SA

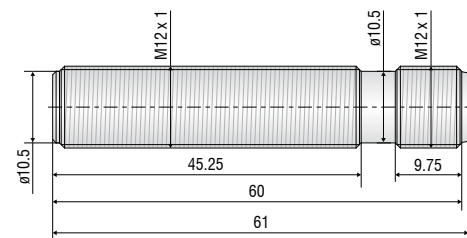

MDS-35-M12-CA-HT

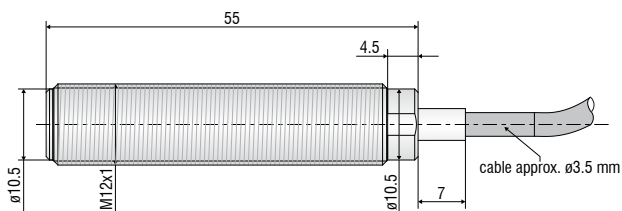

MDS-35-M12-SA-HT

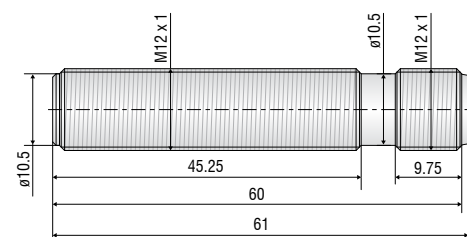

(Dimensions in mm, not to scale)

| Model | MDS-45-M12-CA | MDS-45-M12-SA | MDS-35-M12-CA-HT | MDS-35-M12-SA-HT |
|----------------------------------------|--------------------------------------------------------------------|----------------------------------------------------------------------------------|--------------------------------------------------------------------|----------------------------------------------------------------------------------|
| Measuring range ¹⁾ | 45 mm (for other measuring ranges see page 18) | | 35 mm (for other measuring ranges see page 18) | |
| Magnet included in delivery | MB45 | | MB35HT | |
| Start of measuring range ¹⁾ | 5 mm | | 1 mm | |
| Resolution ³⁾ | 0.05 % FSO | | | |
| Linearity ¹⁾²⁾ | ≤ ±3% FSO | | ≤ ±5% FSO | |
| Repeatability | ≤ ± 0.05 % FSO | | | |
| Frequency response (-3dB) | 3000 Hz | | 5000 Hz | |
| Temperature stability | ≤ 250 ppm FSO/K | | ≤ 500 ppm FSO/K | |
| Supply voltage | 11.5 ... 30 VDC | | | |
| Max. current consumption | 20 mA | | 15 mA | |
| Analog output | 2 ±0.3 ... 9.6 ±0.4 V | | 2 ±0.4 ... 9.6 ±0.4 V | |
| Connection | Supply/signal: integrated cable 4-pin, length 3 m; open ends | Supply/signal: M12 screw/plug connection 4-pin; axial output ⁵⁾ | Supply/signal: integrated cable 4-pin, length 3 m; open ends | Supply/signal: M12 screw/plug connection 4-pin; axial output ⁵⁾ |
| Mounting | Thread M12x1 | | | |
| Temperature range | Storage | -20 ... +80 °C | | -20 ... +120 °C |
| | Operation | -20 ... +80 °C | | -20 ... +120 °C |
| Pressure resistance | 100 bar (front) | | 5 bar (front & rear) | 5 bar (front) |
| Shock (DIN-EN 60068-2-27) | 40 g / 6 ms, 1000 shocks ; 100 g / 6 ms, 3 shocks | | | |
| Vibration (DIN EN 60068-2-6) | 10 ... 58 Hz ±1.5 mm / 58 ... 500 Hz ±20 g per axis, 10 cycles | | | |
| Protection class (DIN-EN 60529) | IP67 ⁴⁾ ; higher protection class available on request | | IP68 permanent | IP65 ¹⁾ |
| Material | Stainless steel | | | |
| Weight | approx. 60 g | approx. 20 g | approx. 25 g | approx. 20 g |
| Features | - | - | - | - |

FSO = Full Scale Output

¹⁾ Measuring range changes by using other magnets (see catalog p.18); external magnetic fields and/or ferromagnetic material in the measuring range of the sensor system affect the sensor characteristic line and the technical data.

²⁾ Deviation to the regression curve according to the method of least squares

³⁾ Peak-Peak; external first-order low pass; frequency response 5 kHz

⁴⁾ For plug versions only in plugged and screwed condition

⁵⁾ Connection cable see accessories

Sensor signal

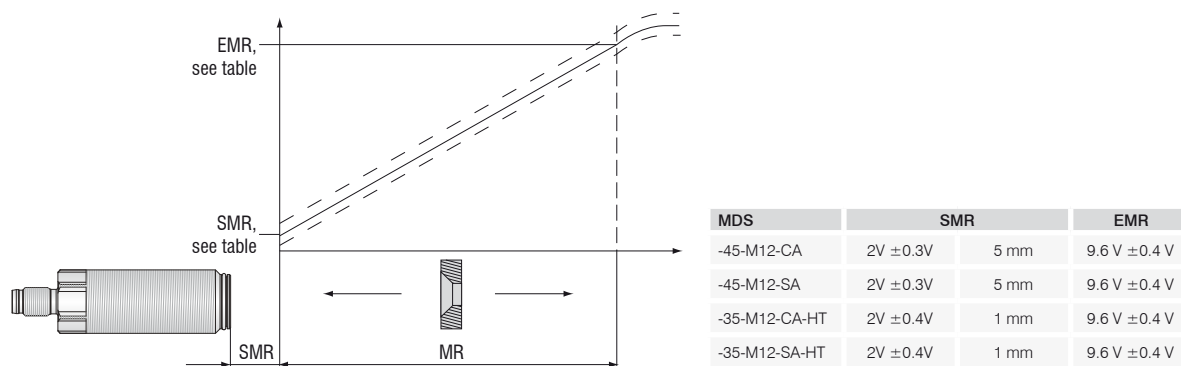

MR = Measuring range, SMR = Start of measuring range, EMR = End of measuring range



The sensors of the MDS-40-MK series are the new generation of cost-effective and flexible magneto-inductive sensors. In addition to the pre-configured preferred types, a combination of further options (power supply, output, plug,...) for serial or industrial applications is possible.

Possible combinations

The following combinations are possible from a quantity of 200 pieces.

Options

MDS - 40 - MK - SA8 - I - 1130 - IP20 - FIX

FIX: Optimal retaining plate for curved surfaces

Protection class: IP67 (casting)
IP20V (IP20 with partial casting)
IP20 (not molded)

Supply voltage: 1130 (11...30 V)
5 (5 V)
33 (3.3 V)

Output: I (4...20 mA)
U10 (2...10 V)
U45 (0.5...4.5 V)
U45R (0.5...4.5 V, ratiometric)
F (frequency: time measurement)

Connection: SA8 (M8x1, axial)
SR7 (JST JWPF, radial)
SR0 (JST PA, radial)

| | | Power supply | | |
|------------------|------|-------------------|-----|-----|
| | | 1130 | 5 | 33 |
| Output | I | • | - | - |
| | U10 | • | - | - |
| | U45 | • | • | - |
| | U45R | - | • | • |
| | F | • | • | • |
| | | Connector / cable | | |
| | | SA8 | SR7 | SR0 |
| Protection class | IP20 | • | • | • |
| | IP67 | • | • | - |

- Combination possible
- Combination not possible

Main measurement direction

The above-mentioned data refer to the main measurement direction; however, other magnet arrangements and directions of movement are possible and can result in a change of the characteristic line. The magnets can be positioned either to the left or to the right of the sensor regardless of whether the north or the south pole is turned towards the sensor.

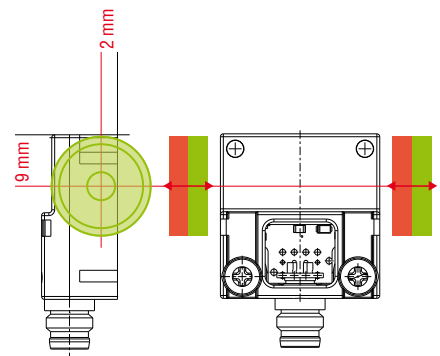



MDS-40-D18-SA sensors are industrial-grade, magneto-inductive sensors with optimized price/performance ratio. These stand out due to the common characteristics of this product series and also because of their robust standard housing designed for clamp fastening.

The stainless steel housing protected to IP67 is ideal for demanding environments (dirt, oil, chemicals) and the food industry.

MDS-40-D18-SA

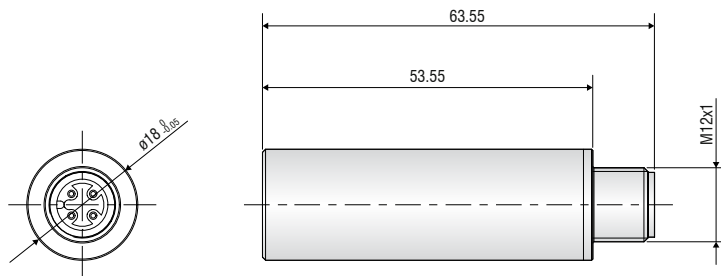

(Dimensions in mm, not to scale)

| Model | | MDS-40-D18-SA |
|----------------------------------------|-----------|---------------------------------------------------------------------------|
| Measuring range ¹⁾ | | RL21 magnet: 30 mm (for other measuring ranges see page 18) |
| Magnet included in delivery | | - |
| Start of measuring range ¹⁾ | | Magnet RL21: 1.5 mm |
| Resolution ³⁾ | Voltage | 0.05 % FSO |
| | Current | 0.2 % FSO |
| Linearity ^{1) 2)} | | $\leq \pm 5\%$ FSO |
| Repeatability | Voltage | $\leq \pm 0.05\%$ FSO |
| | Current | $\leq \pm 0.2\%$ FSO |
| Frequency response (-3dB) | | 1000 Hz |
| Temperature stability | | ≤ 500 ppm FSO/K |
| Supply voltage | | 11.5 ... 30 VDC |
| Max. current consumption | | 20 mA (with voltage output); 42 mA (with current output) |
| Analog output | Voltage | $2 \pm 0.4 \dots 9.6 \pm 0.4$ V |
| | Current | $4 \pm 0.8 \dots 19.2 \pm 0.8$ mA |
| Connection | | Supply/signal: M8 screw/plug connection 4-pin, axial output ⁵⁾ |
| Mounting | | Clamping |
| Temperature range | Storage | -20 ... +80 °C |
| | Operation | -20 ... +80 °C |
| Shock (DIN-EN 60068-2-27) | | 40 g / 6 ms, 1000 shocks / 100 g, 6 ms, 3 shocks |
| Vibration (DIN EN 60068-2-6) | | 10 ... 58 Hz ± 1.5 mm / 58 ... 500 Hz ± 20 g per axis, 10 cycles |
| Protection class (DIN-EN 60529) | | IP67 ⁴⁾ |
| Material | | Stainless steel 1.4404, nickel-plated brass on request |
| Weight | | approx. 55 g |
| Features | | - |

FSO = Full Scale Output

¹⁾ Measuring range changes by using other magnets (see catalog p.18); external magnetic fields and/or ferromagnetic material in the measuring range of the sensor system affect the sensor characteristic line and the technical data.

²⁾ Deviation to the regression curve according to the method of least squares

³⁾ Peak-Peak; external first-order low pass; frequency response 5 kHz

⁴⁾ For plug versions only in plugged and screwed condition

⁵⁾ Connection cable see accessories

Sensor signal

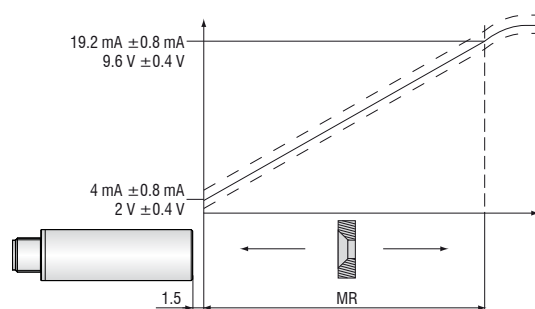

MR = Measuring range

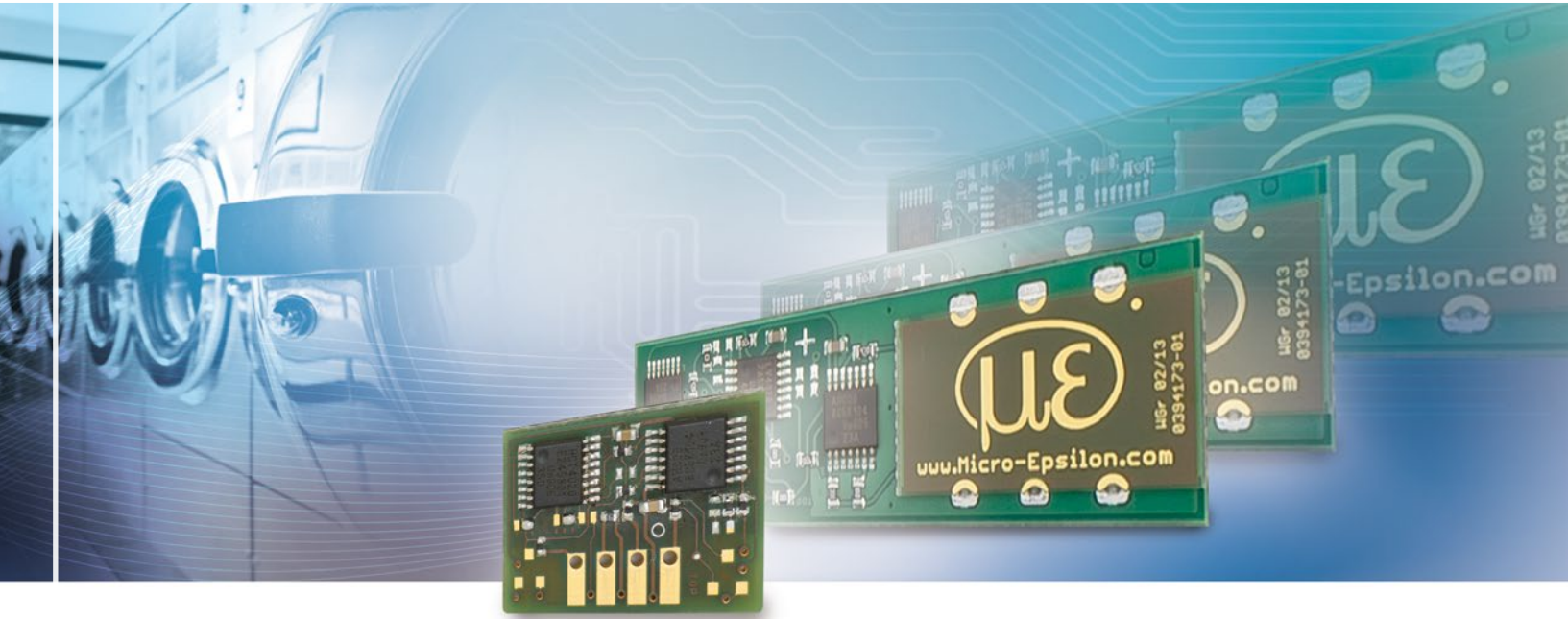

The MDS-40-LP sensors are specially designed for large scale production from 2,000 pieces. As these sensors are reduced to pure measurement technology, the creation of cost-effective PCB sensors was possible. Their flat design and flexible arrangement of the magnets enable easy integration in restricted spaces. Measured values are output via a rectangular signal, which is easily evaluated via, for example, digital inputs from micro-controllers.

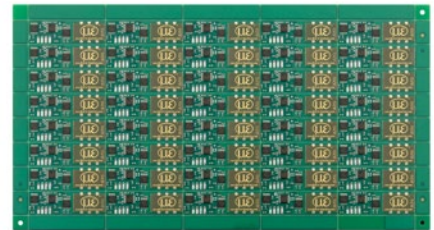

| Model | MDS-40-LP-SUS | MDS-40-LP-F |
|-------------------------------|---------------------------------------------------------------------------------------------------------------------------|---------------------------------------------------------|
| Measuring range ¹⁾ | 40 mm | 40 mm |
| Magnet included in delivery | - | - |
| Resolution ²⁾ | 0.05 % FSO | 0.05 % FSO |
| Linearity ^{1) 2)} | ≤ ±6% FSO | ≤ ±9% FSO |
| Repeatability | | ≤ 0.05% FSO |
| Temperature stability | ≤ 0.06 % FSO / K | ≤ 0.2 % FSO / K |
| Supply voltage | | 3.6 ... 5.3 VDC |
| Max. current consumption | | typ. 15 mA (5 VDC); 12 mA (3.6 VDC) |
| Analog output | Period duration (rectangle): typ. 2.0 ms ... 3.3 ms (p.19) | Period duration (rectangle): typ. 1.0 ... 1.7 ms (p.19) |
| Connection | Supply/signal: plug-in connection to a PCB or solder pads; grid size 2.5 mm | |
| Temperature range | Storage | -20 ... +85 °C |
| | Operation | -20 ... +85 °C |
| Weight | approx. 4.5 g | approx. 1.5 g |
| Features | Sensor module for integration: EMC & ESD protection and voltage stabilization must be provided externally if required. | |
| Min. order quantity | 2,000 pc. | 5,000 pc. |

FSO = Full Scale Output

¹⁾ Measuring range changes by using other magnets (see catalog p.18); external magnetic fields and/or ferromagnetic material in the measuring range of the sensor system affect the sensor characteristic line and the technical data.

²⁾ Deviation to the regression curve according to the method of least squares

³⁾ Without reverse polarity protection, without overvoltage protection

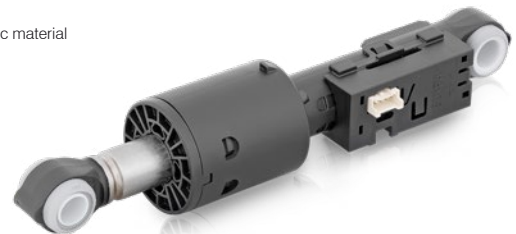

Sensors for customer-specific requirements

If necessary, the sensors can be individually adapted to the customers' requirements. Particularly in the case of high volume orders, customized sensors can be produced efficiently, which results in considerable cost reductions.

The compact PCB which contains the sensor element and the evaluation electronics is responsible for the signal preparation, signal evaluation and signal output. The type of measurement (distance or rotational speed measurement) and the required frequency response are adaptable. In addition, the interfaces offer numerous connectivity options. There are several outputs such as current, voltage, PWM and further digital outputs.

The design of the housing, the material and the protection class can be adapted to the specific requirements. In cases where space is limited, the side shifted measurement offers a space-saving alternative. For harsh environments, the sensor is designed with a fully sealed stainless steel housing that withstands high pressure, dirt, aggressive chemicals (acids) and solvents.



The PCB can be easily integrated and modified for customer-specific solutions – even in limited spaces.

Customer-specific solutions at a glance

- High cost efficiency with serial production
- Ideal for miniature applications
- Flexible design (sensor on PCB)
- Laterally displaced measurement arrangement (damper arrangement)
- Output signal (current, voltage, frequency...)
- Increased pressure resistance
- Frequency response up to 20 kHz



Customer-specific modification even for rotational speed measurement with magnetically biased sensors

For rotational speed measurements of ferromagnetic objects such as toothed racks, the sensor can be magnetically biased. This means that the magnet is integrated into the housing. For this customer-specific solution a factory calibration is required. The movement of the toothed racks affects the magnetic field, which is required for the speed measurement. Here, the measuring range is reduced from 6 mm to 7 mm. The speed measurement can also be carried out through non-ferromagnetic materials.

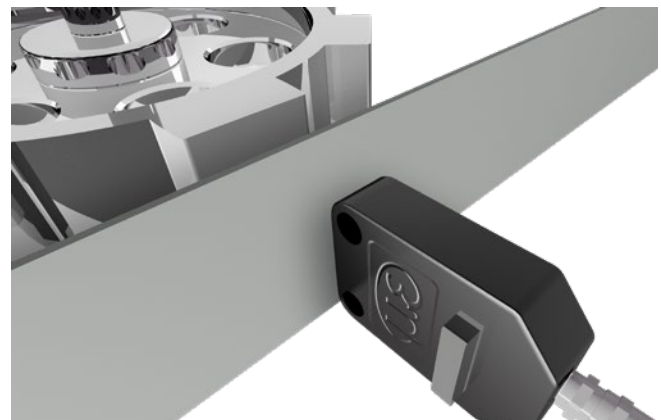

Magnetically biased sensor for speed measurement of toothed racks

Accessories**Supply and output cables for solid metal sensors**

- Art.No. 2901617 PC5/4 (5 m, shielded, straight connector, M8x1, PUR, open ends)
 Art.No. 2901600 PC5/4/90 (5m, shielded, angle plug, M8x1, PUR, open ends)

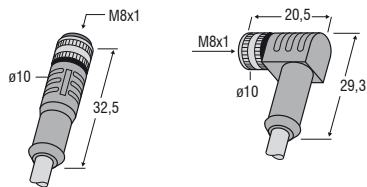
**Power and output cable for sensors made from plastics**

- Art.No. 2901599 PC5/4(01) (5 m, unshielded, straight connector, M8x1, PUR, open ends)
 Art.No. 2901600.01 PC5/4/90(01) (5 m, unshielded, angle plug, M8x1, PUR, open ends)

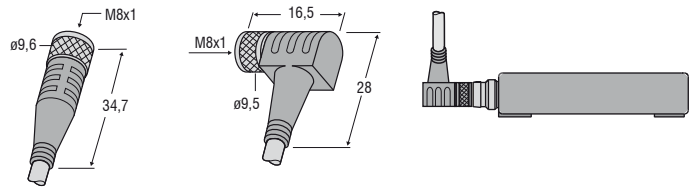
**Supply and output cable**

- Art.No. 29011154 PC5/5-IWT (5 m, shielded, straight connector, M12x1, PVC, open ends)

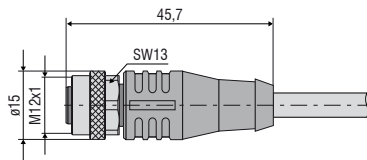
**Supply and output cable**

- Art.No. 29011212 PC5/5-HT-IWT (5 m, shielded, straight connector, M12x1, PTFE (up to 260 °C, open ends)

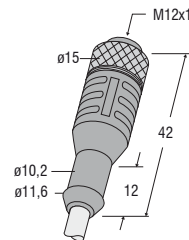
**Supply and output cable**

- Art.No. 29011102 PC1/4-SR0 (1 m, single strands, PVC, JST PA connector, open ends)

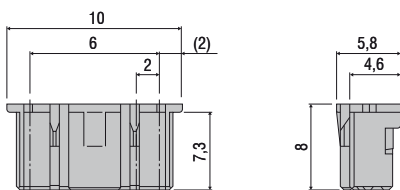
**Supply and output cable**

- Art.No. 29011101 PC1/4-SR7 (1 m, single strands, PVC, JST JWPF connector, open ends)

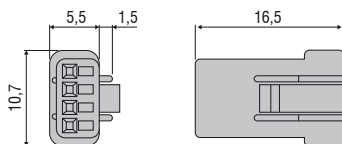

Pin assignment M8x1

| Pin | Description |
|--------|--------------------------------------------|
| 1 | Supply voltage |
| 2 | Output signal 4 mA ... 20mA / n.c. |
| 3 | GND |
| 4 | Output signal 2V ... 10 V |
| Shield | connect shield to the ground ¹⁾ |

1) With metal sensors connected to housing

Pin assignment
View on connector side

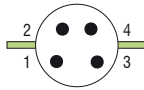

Pin assignment M8x1 (SA8)

| Pin | Description |
|-------------------------------|----------------|
| 1 | Supply voltage |
| 2 | GND Out |
| 3 | GND supply |
| 4 | + Out |
| GND pins internally connected | |

Pin assignment
View on connector side

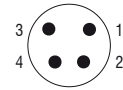

Pin assignment M12x1

| Pin | Description |
|--------|--------------------------------------------|
| 1 | Supply voltage |
| 2 | Output signal 4 mA ... 20mA / n.c. |
| 3 | GND |
| 4 | Output signal 2V ... 10 V |
| Shield | connect shield to the ground ¹⁾ |

1) With metal sensors connected to housing

Pin assignment
View on connector side

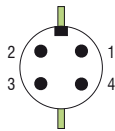

Pin assignment JST JWPF (SR7)

| Pin | Description |
|-------------------------------|----------------|
| 1 | Supply voltage |
| 2 | GND Out |
| 3 | GND supply |
| 4 | + Out |
| GND pins internally connected | |

Pin assignment
View on connector side

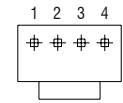

Pin assignment CA

| Pin | Color | Color HT | Description |
|--------|-------|----------|--------------------------------------------|
| 1 | brown | red | Supply voltage |
| 2 | white | - | Output signal 4 mA ... 20mA / n.c. |
| 3 | blue | blue | GND |
| 4 | black | black | Output signal 2V ... 10 V |
| Shield | | | connect shield to the ground ¹⁾ |

1) With metal sensors connected to housing

Pin assignment JST PA (SR0)

| Pin | Description |
|-------------------------------|----------------|
| 1 | Supply voltage |
| 2 | GND Out |
| 3 | GND supply |
| 4 | + Out |
| GND pins internally connected | |

Pin assignment
View on connector side

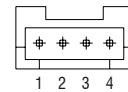

Pin assignment PC5/4

| Pin | Color |
|--------|-------|
| 1 | brown |
| 2 | white |
| 3 | blue |
| 4 | black |
| Shield | |

Pin assignment
View on connector side



Pin assignment PC5/5

| Pin | Color |
|--------|-------|
| 1 | brown |
| 2 | white |
| 3 | blue |
| 4 | black |
| 5 | gray |
| Shield | |

Pin assignment
View on connector side

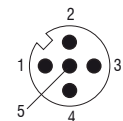

Magnets

The magnets are critical components of the magneto-inductive measuring principle.

Many shapes and materials are available. Application, installation space, temperature and cost factors must be considered. A decisive advantage is that the measuring range of the sensor can be defined by selecting the appropriate magnet. Adapting or set up of the sensor are unnecessary.

Therefore, measuring ranges of 20 to 55 mm can be achieved using only one sensor.

Simple change of the measuring range by exchanging the magnet (MDS-45)

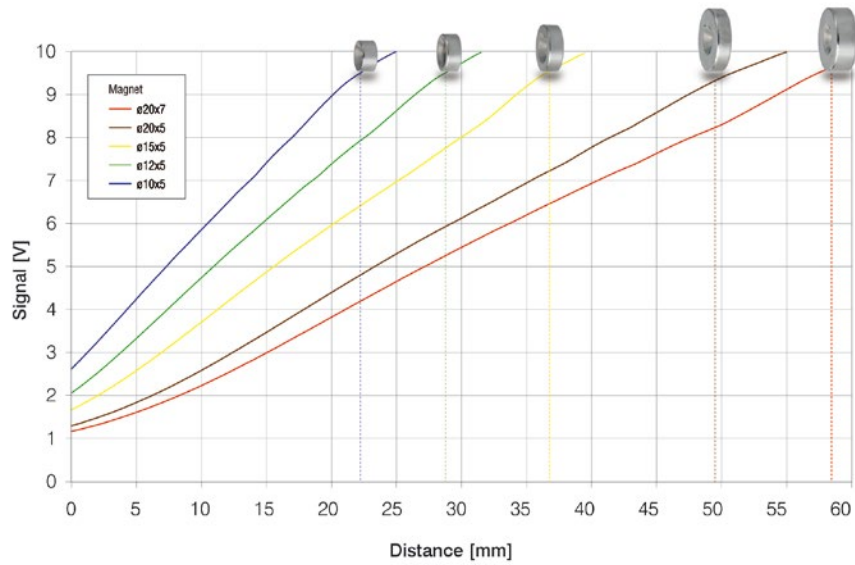

| Designation | Measuring range MDS-45 [mm] | Measuring range MDS-35 HT [mm] | Measuring range MDS-40-MK [mm] | T _{max} [°C] | Standard magnets | | | | Standard magnets in pressure housing | | | | | | |
|-------------|-----------------------------|--------------------------------|--------------------------------|-----------------------|----------------------|----|-----|------|--------------------------------------|----------------------|----|-----|---|----|-----|
| | | | | | Material | d | D1 | D2 | H | Material | d | H | L | M | S |
| MB20 | 20 | 14 | - | 150 | NeFeB, nickel-plated | 10 | 4.3 | 8.6 | 5 | 1.3964 Nitronic 50HS | 16 | 9.5 | 5 | M4 | 2 |
| MB27 | 27 | 18 | ~ 23 | 150 | NeFeB, nickel-plated | 12 | 4.3 | 8.6 | 5 | 1.3964 Nitronic 50HS | 16 | 9.5 | 5 | M4 | 2 |
| MB35 | 35 | 24 | ~ 33 | 150 | NeFeB, nickel-plated | 15 | 4.3 | 8.6 | 5 | 1.3964 Nitronic 50HS | 26 | 14 | 7 | M6 | 3.5 |
| MB45 | 45 | 32 | ~ 45 | 150 | NeFeB, nickel-plated | 20 | 4 | 8 | 5 | 1.3964 Nitronic 50HS | 26 | 14 | 7 | M6 | 3.5 |
| MB55 | 55 | 38 | ~ 50 | 150 | NeFeB, nickel-plated | 20 | 4 | 8 | 7 | 1.3964 Nitronic 50HS | 26 | 14 | 7 | M6 | 3.5 |
| RL21 | 33 | 22 | ~ 30 | 200 | SrFe, hard ferrite | 20 | 4.3 | - | 10 | - | - | - | - | - | - |
| RL20 | 25 | 12 | ~ 25 | 200 | SrFe, hard ferrite | 20 | 4.3 | - | 6.5 | - | - | - | - | - | - |
| MB35HT | 52 | 35 | - | 250 | Sm2Co5 | 22 | 5.2 | 10.4 | 6 | - | - | - | - | - | - |

Magnets at higher temperatures

Permanent magnets present reversible and irreversible temperature dependence. With low temperatures, the magnetic field changes reversibly with the temperature. In the first approximation, this dependence is linear. Irreversible attenuations of the magnetic field are caused by rising temperatures. The main part of these attenuations arises when the temperature is reached for the first time. Therefore, it is recommended that when using magnets in high temperatures, they are heated up only once to the operating temperature or to around 20 °C above the operating temperature, provided that the respective magnet specification allows this.

Please refer to Micro-Epsilon TechNote T016 for further details.

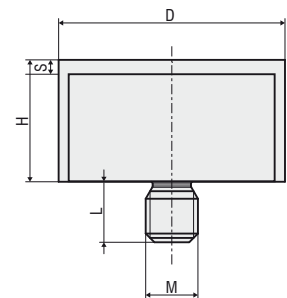
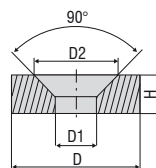

A pressure housing is a method of protecting a magnet from high pressure or aggressive media. This is made from robust stainless steel and resists pressures up to 400 bar.

Rectangular output signals

Effective sensor technology is indispensable with OEM sensors in order to achieve an optimal price/performance ratio. Therefore, many MDS-40 sensors operate based on a rectangular output signal which can be easily generated and evaluated, e.g., via the digital input of a micro-controller. Depending on the type of magnet, the distance signal is proportional to the period of duration or the frequency of the rectangular signal.

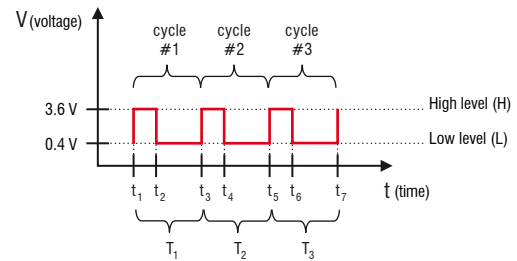

MDS-40-LP-F series

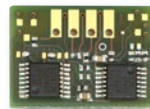
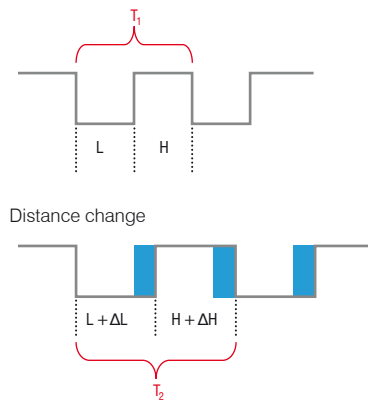

L = time at a low level
H = time at a high level
H and L ~ distance signal

MDS-40-LP-SUS series

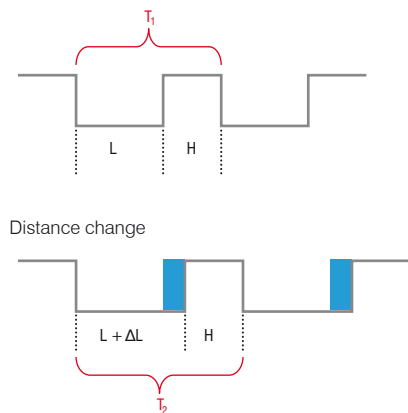

L = time at a low level
H = time at a high level
L ~ distance signal
Details about temperature compensation are available on request

MDS-40-MK series

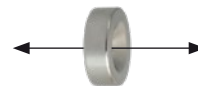
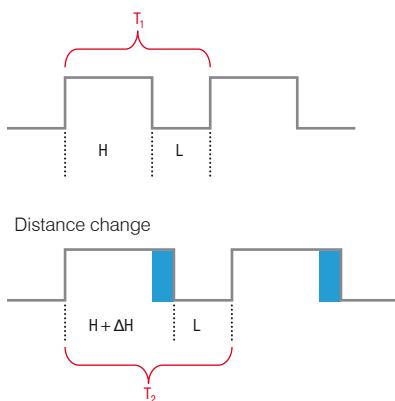

L = time at a low level
H = time at a high level
 $1/(H+L) = f$ ~ distance signal

Sensors and Systems from Micro-Epsilon



Sensors and systems for displacement, distance and position



Sensors and measurement devices for non-contact temperature measurement



Measuring and inspection systems for metal strips, plastics and rubber



Optical micrometers and fiber optics, measuring and test amplifiers



Color recognition sensors, LED analyzers and inline color spectrometers

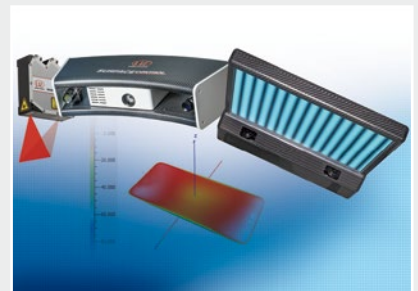

3D measurement technology for dimensional testing and surface inspection