



### SCIGATE AUTOMATION (S) PTE LTD

No.1 Bukit Batok Street 22 #01-01 Singapore 659592

Tel: (65) 6561 0488

Fax: (65) 6562 0588

Email: sales@scigate.com.sg

Web: www.scigate.com.sg

Business Hours: Monday - Friday 8.30am - 6.15pm

# More Precision.



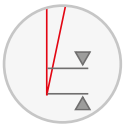

## optoNCDT 1760-1000

Long-range sensor with large measuring range and offset distance





# Long-range sensor with large measuring range and offset distance optoNCDT 1760-1000

-  For usual surfaces
-  Measuring rate up to 7.5 kHz
-  Real Time Surface Compensation
-  Repeatability 100  $\mu\text{m}$



The optoNCDT 1760-1000 long-range sensor has a measuring range of 1000 mm and measures precisely and reliably from just as great a distance on a wide range of material surfaces.

Unlike conventional laser triangulation sensors, long-range sensors measure over a large distance from the target which prevents possible collisions. The integrated RTSC enables precise measurements even on changing surfaces.

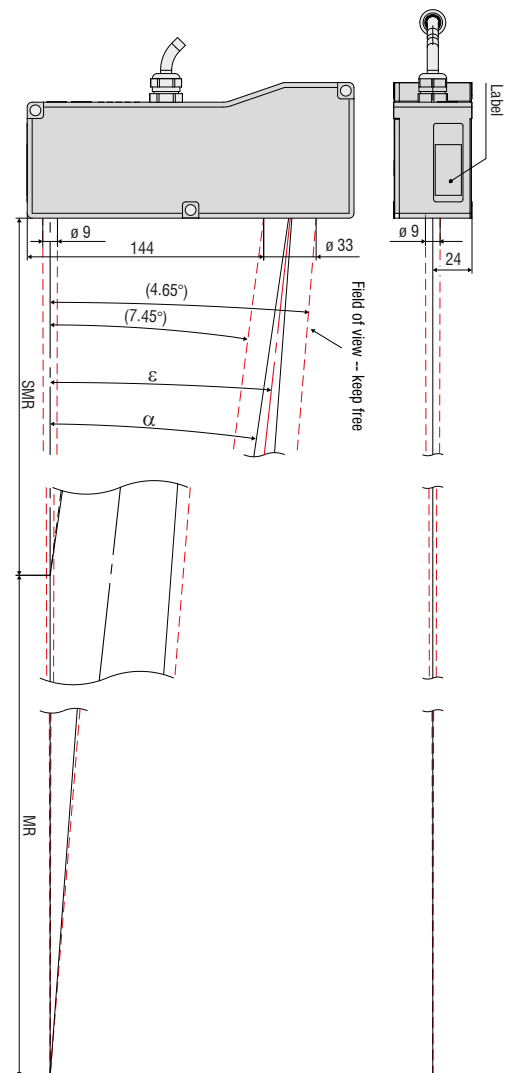
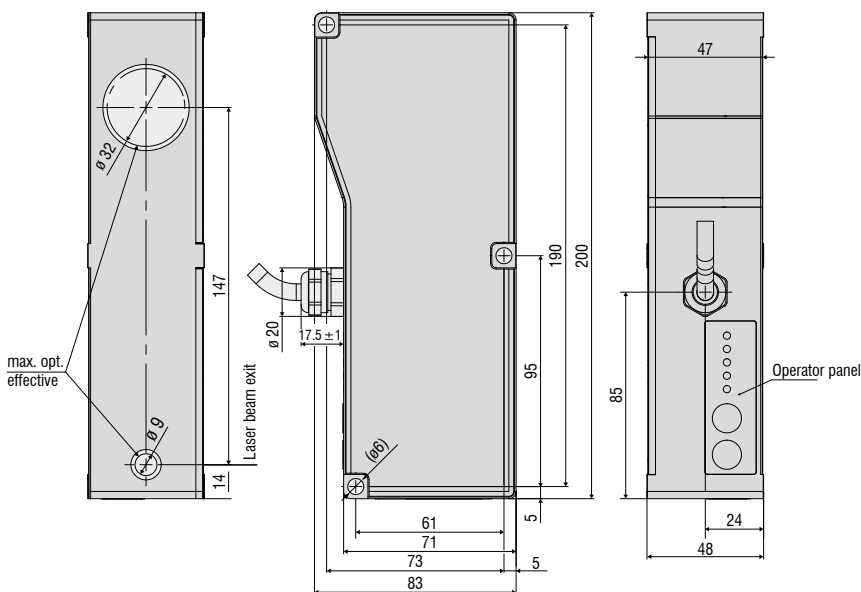

MR	SMR	$\alpha$	$\epsilon$
1000	1000	7.45°	4.65°

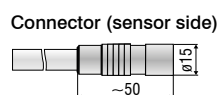

Model	ILD1760-1000	
Measuring range	1000 mm	
Start of measuring range	1000 mm	
Mid of measuring range	1500 mm	
End of measuring range	2000 mm	
Measuring rate <sup>1)</sup>	continuously adjustable between 0.3 ... 7.5 kHz	
	6 adjustable stages: 7.5 kHz / 5 kHz / 2.5 kHz / 1.25 kHz / 625 Hz / 300 Hz	
Linearity	< ±1000 µm	
	< ±0.1 % FSO	
Repeatability <sup>2)</sup>	100 µm	
Light spot diameter (± 10 %)	SMR	2500 ... 5000 µm
	MMR	
	EMR	
Light source	Semiconductor laser < 1 mW, 670 nm (red)	
Laser class	Class 2 in accordance with DIN EN 60825-1: 2015-07	
Permissible ambient light	10,000 lx	
Supply voltage	11 ... 30 VDC	
Power consumption	< 3 W (24 V)	
Signal input	1 x HTL/TTL laser on/off; 1 x HTL/TTL multi-function input: trigger in, slave in, zero setting, mastering, teach-in; 1 x RS422 synchronization input: trigger in, sync in, master/slave, master/slave alternating	
Digital interface	RS422 (16 bit) / PROFINET <sup>3)</sup> / EtherNet/IP <sup>3)</sup>	
Analog output	4 ... 20 mA / 0 ... 5 V / 0 ... 10 V (16 bit, freely scalable within the measuring range)	
Switching output	2x switching outputs (error & limit value): npn, pnp, push pull	
Synchronization	possible for simultaneous or alternating measurements	
Connector	integrated pigtail 0.25 m with 14-pin ODU connector, min. bending radius 30 mm (fixed installation); optional extension to 3 m / 10 m possible	
Mounting	Screw connection via three mounting holes	
Temperature range	Storage	-20 ... +70 °C (non-condensing)
	Operation	0 ... +50 °C (non-condensing)
Shock (DIN EN 60068-2-27)	15 g / 6 ms in 3 axes	
Vibration (DIN EN 60068-2-6)	2 g / 20 ... 500 Hz	
Protection class (DIN EN 60529)	IP65	
Material	Aluminum housing	
Weight	approx. 800 g (incl. pigtail)	
Control and indicator elements	Select & function keys: interface selections, mastering (zero), teach, presets, quality slider, frequency selection, factory settings; web interface for setup <sup>4)</sup> : application-specific presets, peak selection, video signal, freely selectable averaging possibilities, data reduction, setup management 2 x color LEDs for power / status	

FSO = Full Scale Output

SMR = Start of measuring range, MMR = Mid of measuring range, EMR = End of measuring range

The specified data apply to a white, diffuse reflecting surface (Micro-Epsilon reference ceramic for ILD sensors)

<sup>1)</sup> Factory setting 5 kHz, modifying the factory setting requires the IF2001/USB converter (see accessories)

<sup>2)</sup> Measuring rate 5 kHz, median 9

<sup>3)</sup> Connection via interface module IF2030

<sup>4)</sup> Connection to PC via IF2001/USB

## Sensors and Systems from Micro-Epsilon



Sensors and systems for displacement, distance and position



Sensors and measurement devices for non-contact temperature measurement



Measuring and inspection systems for metal strips, plastics and rubber



Optical micrometers and fiber optics, measuring and test amplifiers



Color recognition sensors, LED analyzers and inline color spectrometers



3D measurement technology for dimensional testing and surface inspection