

Quick Manual interferoMETER

IMS5400-DS
IMS5600-DS
IMS5400-TH

Contents

General	3
Symbols used	3
Warnings	3
Intended Use	4
Proper Environment	4
Glossary	5
Laser Safety	5
Operating Modes	6
Setup, Connection Options	6
Sensor Cable	7
Mounting, Mounting Adapter	7
Pluggable Screw Terminals	8
LEDs Controller	9
Button Multifunction	10

Initial Operation	11
Select a Sensor	11
Start of Measuring Range, Working Distance	11
Positioning the Target, Distance Measurement	12
Positioning the Target, Thickness Measurement	13
Material Selection	13
Measurement Configuration	14
FFT Signal Check	15
Signal Quality	15
Distance and Thickness Measurement with Web Page Display	16
Data Output, Interface Selection	18
Ethernet	18
Set IP Address	19
Service, Repair	19
Liability for Material Defects	19

MICRO-EPSILON
MESSTECHNIK
GmbH & Co. KG
Koenigbacher Str. 15

94496 Ortenburg / Germany

Tel. +49 (0) 8542 / 168-0
Fax +49 (0) 8542 / 168-90
e-mail info@micro-epsilon.com
www.micro-epsilon.com

You can find further information about the measurement system in the operating instructions. They are available at:

[www.micro-epsilon.com/download/manuals/
man-interferoMETER-5x00--en.pdf](http://www.micro-epsilon.com/download/manuals/man-interferoMETER-5x00--en.pdf)



General

Symbols used

The following symbols are used in this document:



Indicates a hazardous situation which, if not avoided, may result in minor or moderate injury.



Indicates a situation that may result in property damage if not avoided.



Indicates a user action.



Indicates a tip for users.

Measure

Indicates hardware or a software button/menu.

Warnings



Connect the power supply and the display/output device according to the safety regulations for electrical equipment.

> Risk of injury, damage to or destruction of the controller



The supply voltage must not exceed the specified limits.

> Damage to or destruction of the controller

Avoid shocks and impacts to the sensor and the controller.

> Damage to or destruction of the components

Never kink optical fibers or bend them in tight radii.

> Damage to or destruction of the optical fibers; failure of measurement device

Protect the ends of the optical fibers against contamination

> Failure of the measuring device

Protect the cable against damage.

> Failure of the measuring device

Intended Use

- The interferoMETER measuring system is designed for use in an industrial environments and domestic areas. It is used for
 - measuring displacement, distance, profile, thickness and surface inspection
 - monitoring quality and checking dimensions.
- The measuring system must only be operated within the limits specified in the technical data.
- The measuring system must be used in such a way that no persons are endangered or machines and other material goods are damaged in the event of malfunction or total failure of the controller.
- Take additional precautions for safety and damage prevention in case of safety-related applications.

Proper Environment

- Protection class
 - sensor: IP40 (with connected sensor cable only)
 - controller: IP40

Lenses are excluded from protection class. Contamination of the lenses causes impairment or failure of the function.

- Temperature range
 - operation
 - sensor: +5 ... +70 °C (+41 ... +158 °F)
 - controller: +15 ... +35 °C (+59 ... +95 °F)
 - storage: -20 ... +70 °C (-4 ... +158 °F)
- Humidity: 5 - 95 % (non-condensing)
- Ambient pressure: Atmospheric pressure
- EMC: According to EN 61000-6-3 / EN 61326-1 (Class B) and EN 61 000-6-2 / EN 61326-1

Glossary

MR = Measuring range

SMR = Start of measuring range

MMR = Mid of measuring range (=SMR + 0.5MR)

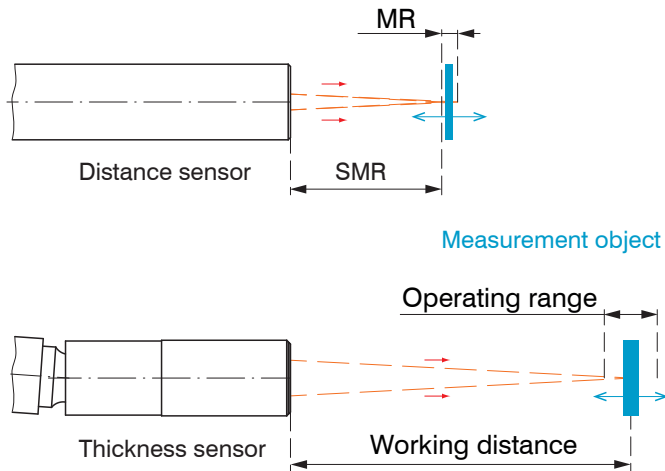

You can find further information about the sensors in the operating instructions, chapter Technical Data.

Laser Safety

The interfeROMETER measuring system works with a pilot laser of a wavelength of 635 nm (visible / red) offering max. power of < 0.01 mW and a measuring laser of a wavelength of 840 nm with a max. power of < 0.2 mW.

The measuring system falls within laser class 1. The accessible radiation is harmless under predictable conditions.

For class 1 laser devices, impairment of color vision and disturbances, e.g., from a glare effect, cannot be excluded.

An LED signalizes by illumination that laser radiation emits from the optical opening of the light source ("Pilot on").

LASER Klasse 1
nach DIN EN 60825-1: 2015-07
 $P \leq 0,01 \text{ mW}$; $\lambda = 635 \text{ nm}$

Class 1 Laser Product
IEC 60825-1: 2014
 $P \leq 0.01 \text{ mW}$; $\lambda = 635 \text{ nm}$
COMPLIES WITH 21 CFR 1040.10 AND 1040.11 EXCEPT FOR CONFORMANCE WITH IEC 60825-1 ED. 3., AS DESCRIBED IN LASER NOTICE NO. 56, DATED MAY 8, 2019.

LASER Klasse 1
nach DIN EN 60825-1: 2015-07
 $P \leq 0,2 \text{ mW}$; $\lambda = 840 \text{ nm}$

Class 1 Laser Product
IEC 60825-1: 2014
 $P \leq 0.2 \text{ mW}$; $\lambda = 840 \text{ nm}$
COMPLIES WITH 21 CFR 1040.10 AND 1040.11 EXCEPT FOR CONFORMANCE WITH IEC 60825-1 ED. 3., AS DESCRIBED IN LASER NOTICE NO. 56, DATED MAY 8, 2019.

Operating Modes

The interferoMETER measuring system provides highly accurate measurements of

- distances against visually dense materials with light-diffusing or reflective surfaces
- thicknesses for transparent layer materials.

By selecting the sensor, the distance or thickness measurement operating mode is selected.

Accordingly, the result of the measurement is a distance or thickness value.

	Distance measurements	Thickness measurements
Measuring range	2.1 mm	35 μm ... 1.4 mm ¹

Measuring ranges for distance and thickness measurements

The possible resolution here is in the nanometer range. For a quick start, we recommend to use presets defined for different target surfaces and applications, see operating instructions Chap. 6.6.

- 1) Measuring range with $n=1.5$; for air gap measurement between two glass plates ($n\sim 1$) the measuring range is 0.05 ... 2.1 mm. The measurement object must be within the working distance.

Setup, Connection Options

- ➡ Connect the components together and mount the sensors into the clamps.

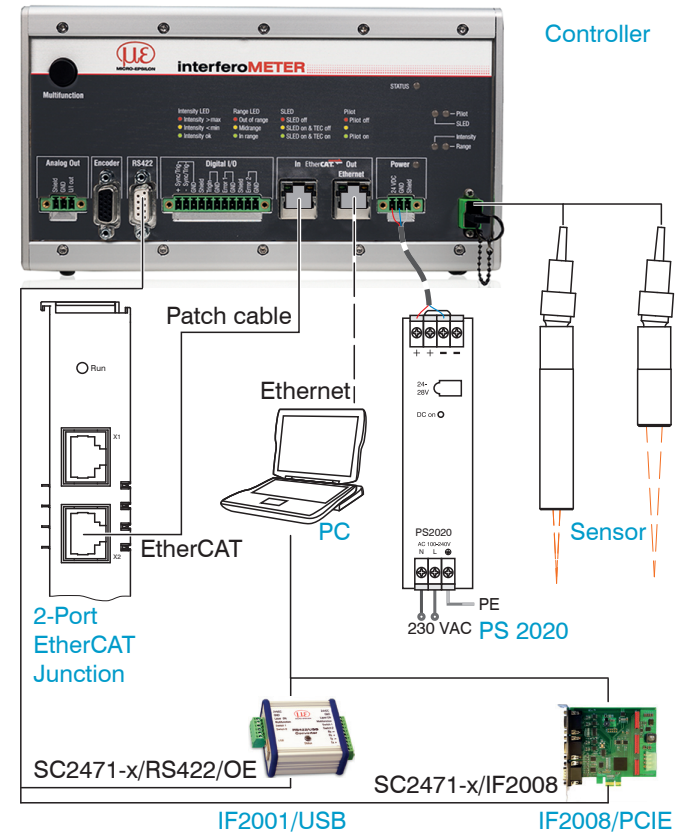

Sensor Cable

Sensor and controller are connected through an optical fiber.

- Do not shorten or extend the optical fiber.
- Do not pull or hold the sensor on the optical fiber.

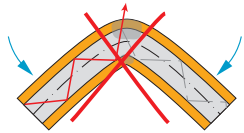

Do not kink the optical fiber.

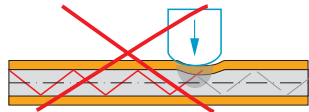

Do not crush the optical fiber, do not fasten it using cable ties.

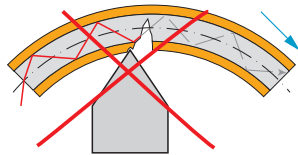

Please do not grind the optical fiber over sharp corners.

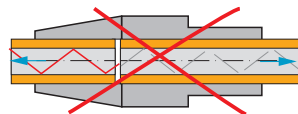

Do not pull the optical fiber.

Cleaning of the connectors requires the corresponding know-how.

General Rules

As a matter of principle, avoid:

- any contamination of the connector, e.g., dust or finger prints
- unnecessary mating cycles.
- any mechanical stress of the optical fiber (bending, crushing, pulling, twisting, knotting etc.).
- tight curvature of the optical fiber because the glass fiber is damaged in the process and this causes permanent damage.

Never bend the cable more tightly than the permissible bending radius.

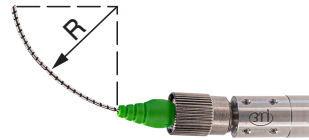

Fixed: $R = 30$ mm or more

Flexible: $R = 40$ mm or more

Mounting, Mounting Adapter

The IMP-DS19 / -TH45 series sensors use an optical measuring principle that allows for measurements in the nm range.

- Ensure careful handling during installation and operation.
- ➡ Mount the sensors with an outer clamp. Use the MA5400-10 mounting adapter from the optional accessories.

This type of sensor installation ensures the highest level of reliability because the sensor's cylindrical cover is clamped over a relatively large area.

Pluggable Screw Terminals

Pin	Description	Comments	
U/I out	Voltage output	0 ... 5 V; 0 ... 10 V; R_i appr. 50 Ohm 5.5 V / 10.9 V with error, outside measuring range	
	Current output	4 ... 20 mA; $R_L \leq 500$ Ohm 23.7 mA with error, outside measuring range	
GND	Ground analog output	Galvanically connected with supply	
+Sync/Trig -Sync/Trig	Synchronization input/output, trigger input	RS422 level (EIA422)	
TrigIn	Trigger input	TTL or HTL level TTL: Low ≤ 0.8 V, High ≥ 2 V HTL: Low ≤ 3 V, High ≥ 8 V	
Error 1 / 2	Switch outputs	NPN, PNP or Push-Pull $I_{max} = 100$ mA, $U_{Hmax} = 30$ V	
GND	Ground potentials	All GND conductors are interconnected with one another and to operating voltage ground.	
24 VDC	Operating voltage	$\pm 15\%$, $I_{max} < 1$ A	
GND	Operating voltage ground	GND is galvanically connected to GND of switching outputs, synchronization, analog and encoder input	
Shield	Shields to respective output/input, connector housing		

The plug-in screw terminals are designed for a conductor cross-section of 0.14 mm² up to 1.5 mm².

LEDs Controller

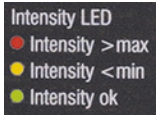
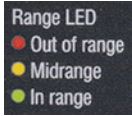
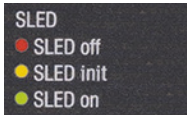
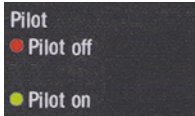
Power on	Green	Operating voltage available	
Status	Off	No error	
	If EtherCAT is active, meaning of the LED is conform with the Ether-CAT guidelines.		
Intensity		Red	Signal in saturation
		Yellow	Signal too low
		Green	Signal ok
Range		Red	No target object, or target object outside the measuring range
		Yellow	Target close to mid of measuring range
		Green	Target within measuring range
SLED		Red	SLED of
		Yellow	SLED warms up
		Green	SLED ready for operation
		Yellow flashing	SLED current outside the optimal value range ¹
Pilot		Red	Pilot laser off
		Green	Pilot laser on
		Green	Pilot laser is alternately turned on and off, if no target object or outside the measuring range

1) When measuring outside the optimum current value of the SLED, the controller will measure, but the measurement accuracy may not be as specified.

The LED's Intensity and Range flashes with their current color during a synchronization error.

Button Multifunction

The Multifunction button of the controller has multiple functions. It enables, e.g., to operate the light source. The button is factory-set to the Pilotlaser on/off feature.

	Key function 1 / 2	Set / reset master value	<i>Starts or stops the master measurement of the selected signals</i>
		Pilot laser	<i>Turns on/off the pilot laser</i>
		SLED	<i>Turns the light source on/off for the sensor</i>
		Inactive	<i>Key has no function</i>

There are two defined time intervals for pressing the button; each of these can be assigned a function. All time intervals are indicated by the LEDs flashing/lighting up.

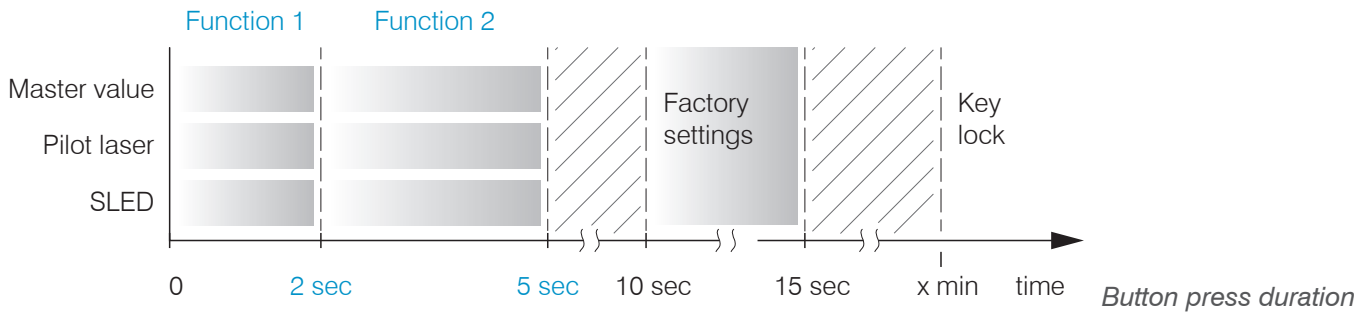

Initial Operation

- Initializing starts after the voltage supply has been switched on. The measuring system is ready for use after approx. 10 seconds. To ensure precise measurements, let the measuring system warm up for approx. 60 minutes.

The controller is factory set to the static IP address 169.254.168.150. Use this address for a direct connection with a browser.

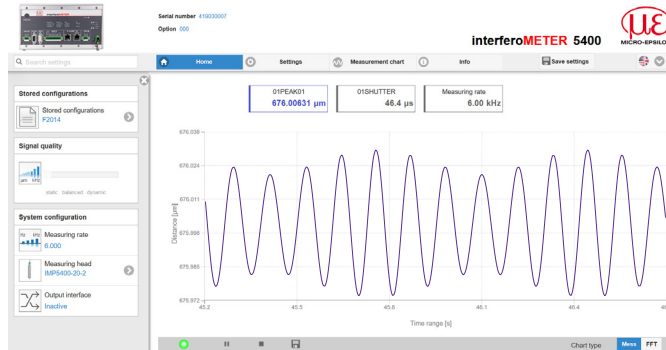

The start screen of the controller software is displayed in the web browser now.

You can check the IP address of the controller, that are connected to a PC / network, with the sensorTOOL.exe program. This program is available online at <https://www.micro-epsilon.de/download/software/sensorTOOL.exe>.

- Start the program sensorTOOL and click the button .
- Click the Open WebPage button to connect the controller to your default browser.

Select a Sensor

- Change to the Settings > Sensor menu.
- Select a sensor from the list.

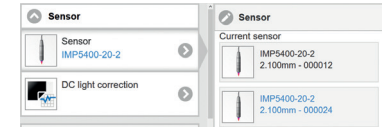

Start of Measuring Range, Working Distance

A base distance (SMR) or working distance must be maintained for each sensor.

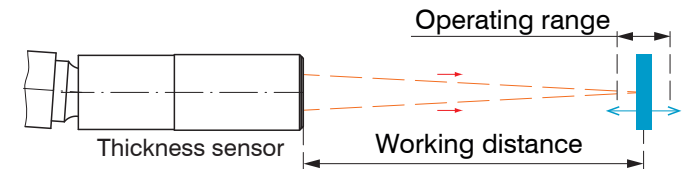
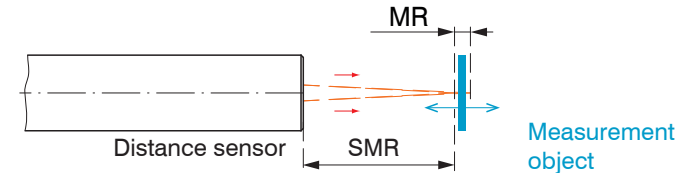

Positioning the Target, Distance Measurement

The red-light pilot laser supports you in aligning the sensor to the target during commissioning.

Turn on or off the pilot laser in the menu `Settings > System settings`.

➡ Position the target (measurement object) as much as possible in the mid of the measuring range.

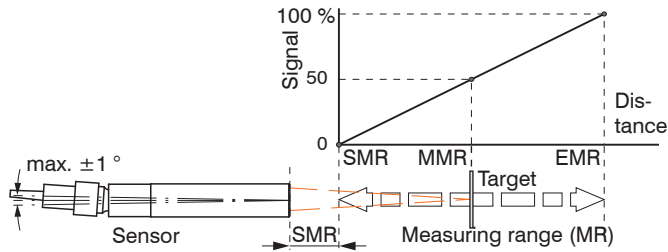

The LED Range on the controller front indicates the position of the target in relation to the sensor.

<div style="background-color: #333; color: white; padding: 5px;"> Pilot ● Pilot off ● Pilot on </div>	<div style="background-color: #333; color: white; padding: 10px; border: 1px solid black;"> Green </div>	Pilot laser is turned on and off alternately, if no target or outside the measuring range
---	--	---

You can also position the sensor using the FFT signal¹. The interferometric measuring principle provides measurement values in front of and behind the actual measuring range. An incorrect measuring range distance can be recognized by the running direction of the peak in the FFT signal. Inverse direction of FFT signal, if the target is outside measuring range.

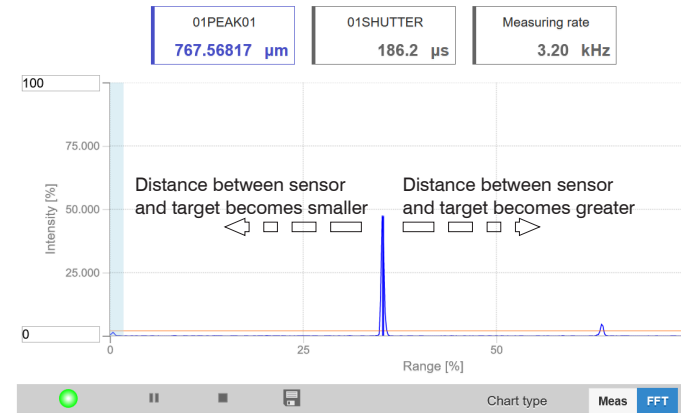

Using the FFT signal for sensor positioning

Range LED ● Out of range ● Midrange ● In range	Red	No target or target outside the measuring range
	Yellow	Target close to mid of measuring range
	Green	Target within measuring range

1) FFT = Fast Fourier Transformation, frequency signal

Positioning the Target, Thickness Measurement

The red-light pilot laser supports you in aligning the sensor to the target during commissioning.

Turn on or off the pilot laser in the menu `Settings > System settings`.

➤ Position the target (measurement object) as much as possible in the mid of the operating range.

The peak positions remains stable in the FFT signal, even though the measurement target moves. The peak position depends on the target thickness.

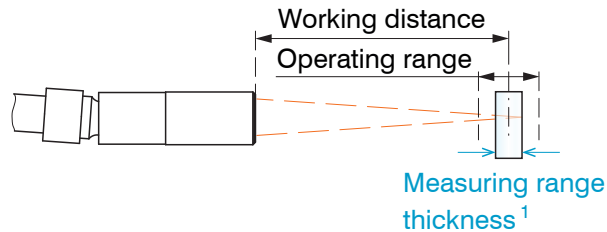

Basics thickness measurement

The LED Range on the controller front indicates the position of the target in relation to the sensor.

	Green	Pilot laser is turned on and off alternately, if no target or outside the measuring range
--	-------	---

Material Selection

To measure the thickness of a material, you must specify the material of the target.

➤ Change to Material selection, menu `Settings > Data recording`.

➤ Select the material based on the target used.

In the controller, you can store the group refractive index of different materials which can be used for direct reflection measurements.

The materials database in delivery state can be restored by loading the factory settings. The materials database allows for up to 20 materials to be stored.

If the corresponding material is now specified for the measurement, the refractive index is included in the calculation and the sensor thus delivers the correct result.

Clicking on the button `Edit material table` expands/reduces the materials database. For a new material, the group refractive index is required.

1) The maximum thickness for a air gap is 2.1 mm. The thickness for glass ($n = 1.5$) is $35 \mu\text{m}$ as a minimum and 1.4 mm as a maximum.

Measurement Configuration

Common measurement configurations (presets) for various target surfaces are stored on the controller and enable to quickly start the respective measurement task. This allows you to quickly start with your individual measurement task. In a preset the basic features like peak or material selection and calculation functions are already set.

▶ Go to the Home > Measurement configuration menu and start the configuration selection.
Select a stored configuration (preset).

The controller also enables user-specific settings. When saving a changed preset, the web interface displays a dialog which enables the user to define a setup name to avoid accidental overwriting. This prevents presets from being overwritten by accident.

Presets:



Standard matt

Distance measurement ¹, e.g. on ceramics, non-transparent plastics. No averaging



Standard glänzend

Distance measurement ¹, e.g. on metals, polished surfaces. Median over 5 values



Multisurface

Distance measurement ¹, e.g. on PCB, hybrid materials.
Median over 9 values



standard thick glass

One-sided thickness measurement ², e.g. of glass.
No averaging



standard thick plastic

One-sided thickness measurement ², e.g. of transparent plastics. No averaging

Individual material selection is possible in the Settings > Data recording > Material selection menu.

- 1) The distance presets are only possible with a IMP-DSxx distance sensor.
- 2) The thickness presets are only possible with a IMP-THxx thickness sensor.

FFT Signal Check

- ➔ Go to the Measurement chart menu. Show FFT signal display with FFT. The signal in the chart window shows the distance between sensor and target or the target thickness. Left 0 % (small distance) and right 100 % (large distance). The corresponding measured value is marked by a vertical line (peak marking). The diagram starts automatically when the website is called.

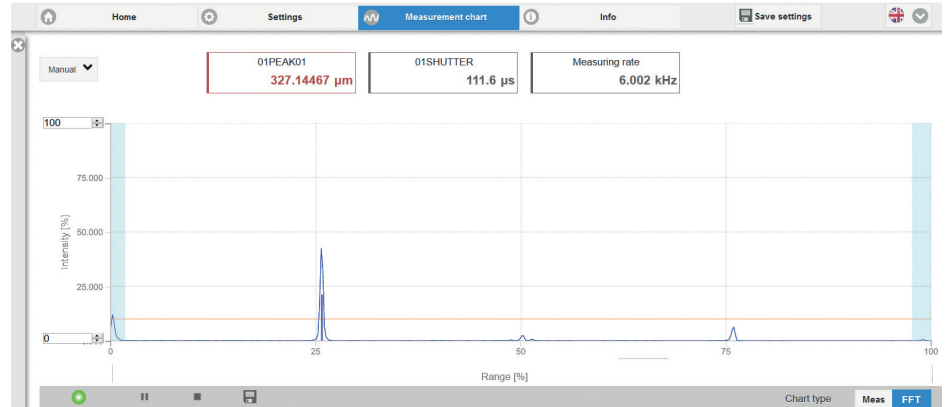

Signal Quality

A good measurement result can be achieved with sufficient FFT signal intensity. Reducing the measuring rate enables longer exposure of the CCD array, therefore leading to high measurement quality.

- ➔ Go to the menu Home > Signal quality and adapt the measurement dynamics to the requirements. Check the result in the FFT signal.

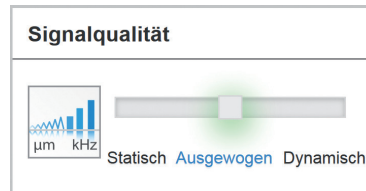

	Measuring rate	Averaging
Static	200 Hz	Moving, 128 values
Balanced	1 kHz	Moving, 16 values
Dynamic	6 kHz	Moving, 4 values

Distance and Thickness Measurement with Web Page Display

- ▶ Align the sensor vertically to the target object.
- ▶ Then, move the sensor (or the target) closer, until you more or less reach the start of measuring range for your sensor.

Once the object is within the sensor's measuring range, the Range LED (green or yellow) on the front of the controller will light up. Or, observe the FFT signal.

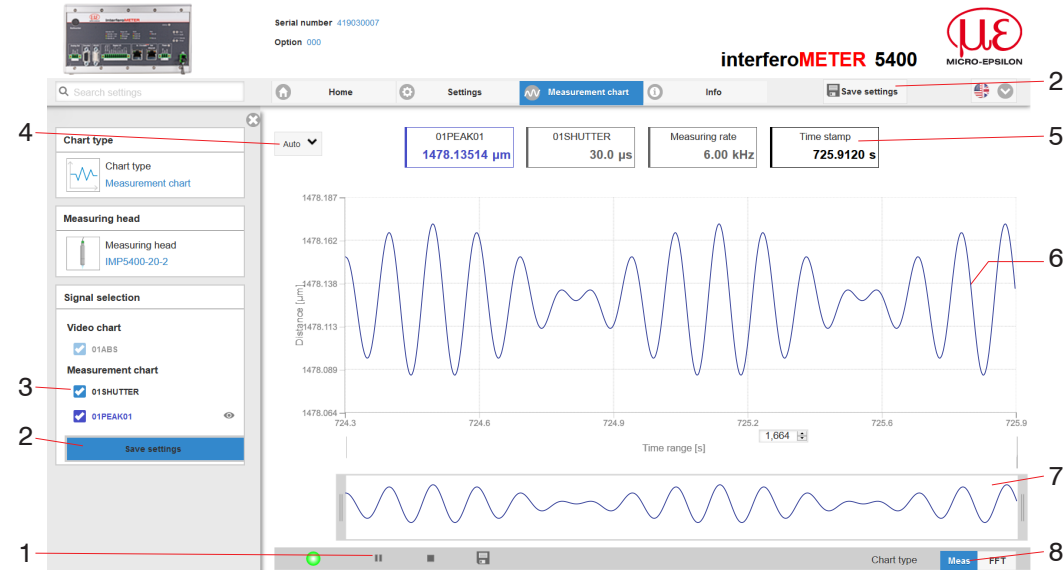

Measurement *web page (distance measurement)*

- 1 The LED visualizes the status of the transmission of measured values:
 - green: transmission of measured values is running.
 - yellow: waiting for data in trigger mode
 - gray: transmission of measured values stopped

Data queries are controlled by using the `Play/Pause/Stop/Save` buttons of the measured values that were transmitted. `Stop` stops the diagram; data selection and zoom function are still possible. `Pause` interrupts recording. `Save` opens the Windows selection dialog for file name and storage location to save the FFT signals resp. measurement values in a CSV file (separation with semicolon).

➡ Click the button ▶ (Start), for starting the display of the measurement results.

- 2 Changes only take effect after clicking the `Save settings` button.
- 3 In the window on the left, the signals can be enabled or disabled both during and after the measurement. Inactive graphs are gray. Click on the check mark to add them. The changes take effect when saving the settings. Use the eye symbols 👁 to show and hide the single signals. The calculation continues in the background.
 - 01PEAK01: Chronological sequence of displacement signal

- 4 `Auto` (= automatic scaling) or `Manual` (= manual setting) allow for scaling the measurement axis (Y axis) of the graphic.
- 5 The current values for distance, exposure time, current measuring rate and time stamp are displayed in the text boxes above the graphic. Errors are displayed as well.
- 6 Mouseover feature. When moving the mouse over the graph, curve points are highlighted with a circle symbol while the corresponding values are displayed in the text boxes above the graph.
- 7 X axis scaling: The total signal is zoomable with the slider on the left side during running measurement. The time range can be defined in the input field below the time axis. If the diagram is stopped, you can also use the right slider. The zoom window can also be moved with the mouse in the center of the zoom window (arrow cross).
- 8 The two buttons allow to switch between FFT signal and measurement representation.

Data Output, Interface Selection

The controller supports

- three digital interfaces that can be used in parallel for data output,
 - Ethernet: enables fast data transfer, but provides no real-time capabilities (packet-based data transfer). Both measurement and FFT data can be transferred. For measurement value detection without direct process control, for subsequent analysis. Parameterization is provided through the web interface or ASCII commands.
 - RS422: provides an interface capable of real-time output at a lower data rate.
 - Switching/limit value output
- Analog output: outputs either voltage or current values.

➤ Switch to the `Settings > Outputs > Output interface` menu and select the desired output channels.

Ethernet

The controller transmits TCP/IP or UDP/IP packages with an Ethernet transfer rate of 10 Mbit/s or 100 Mbit/s. The transfer rate is selected automatically depending on the connected network or PC.

When transmitting measurement data to a measurement server, following successful connection (TCP or UDP), the sensor sends each measurement to the measurement server or to the connected client. No explicit request is necessary for this.

Distance and thickness values are transmitted as 32 bit signed integer value with 10 pm resolution.

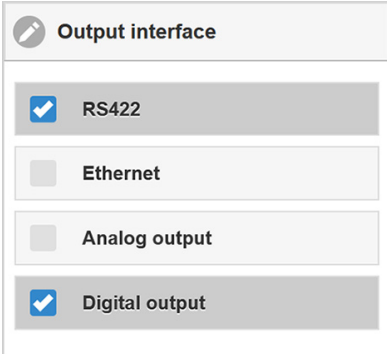

Output interface	
<input checked="" type="checkbox"/>	RS422
<input type="checkbox"/>	Ethernet
<input type="checkbox"/>	Analog output
<input checked="" type="checkbox"/>	Digital output

Selecting the required interfaces for data output

Set IP Address

- ➡ Change to the menu `Settings > Outputs > Ethernet Settings` and enter the new IP address.
- ➡ Click on `Apply settings` to confirm.
- ➡ Start the web interface with the new IP address.
- ➡ Save the new device settings. Click on `Save settings`.

Service, Repair

If the sensor, controller or sensor cable is defective:

- If possible, save the current sensor settings in a parameter set to reload them into the controller after the repair.
- Please send us the affected parts for repair or exchange.

If the cause of a fault cannot be clearly identified, please send the entire measuring system to:

MICRO-EPSILON MESSTECHNIK GmbH & Co. KG
Koenigbacher Str. 15
94496 Ortenburg / Germany

IMS5x00

Liability for Material Defects

All components of the device have been checked and tested for functionality at the factory. However, if defects occur despite our careful quality control, MICRO-EPSILON or your dealer must be notified immediately.

The liability for material defects is 12 months from delivery. Within this period, defective parts, except for wearing parts, will be repaired or replaced free of charge, if the device is returned to MICRO-EPSILON with shipping costs prepaid. Any damage that is caused by improper handling, the use of force or by repairs or modifications by third parties is not covered by the liability for material defects. Repairs are carried out exclusively by MICRO-EPSILON.

Further claims can not be made. Claims arising from the purchase contract remain unaffected. In particular, MICRO-EPSILON shall not be liable for any consequential, special, indirect or incidental damage. In the interest of further development, MICRO-EPSILON reserves the right to make design changes without notification.

For translations into other languages, the German version shall prevail.

Tel. +49 (0) 8542 / 168-0
info@micro-epsilon.de
www.micro-epsilon.com



SCIGATE AUTOMATION (S) PTE LTD

Bukit Batok Street 22 #01-01 Singapore 659592

Tel: (65) 6561 0488

Fax: (65) 6561 0588

Email: sales@scigate.com.sg

Web: <https://scigate.com.sg/>

Business Hours: Monday - Friday 8:30AM - 6:15PM



MICRO-EPSILON MESSTECHNIK GmbH & Co. KG
Koenigbacher Str. 15 · 94496 Ortenburg / Germany
Tel. +49 (0) 8542 / 168-0 · Fax +49 (0) 8542 / 168-90
info@micro-epsilon.com · www.micro-epsilon.com

Your local contact: www.micro-epsilon.com/contact/worldwide/

X9691389-A012090MSC

© MICRO-EPSILON MESSTECHNIK

