



MOBILE WEIGHING

crane scales

CS05

Minimum reduction of the crane area

Adjustable light intensity

Capacity: 300-600-1500 KG, 1500-3000-6000 KG,
3000-6000-9500 KG

Structure in painted steel

Digital calibration

Programmable digital filter

Infrared remote control (standard)

Predisposition for radio interface, for PC or indicator/remote terminal and printer

Available also CE-M approved

TECHNICAL CHARACTERISTICS CS05

| | |
|----------------------|--|
| Display | Backlit 25mm LCD |
| Galvanized shackles: | serial |
| Accuracy: | ± 0.03% on R.L. |
| Keyboard | Waterproof, 5 keys |
| Filter: | Programmable digital set up |
| Power supply: | 4 AA size battery , even rechargeable, 40 hours battery life |
| Telecontrol: | serial |
| Calibration: | Programmable digital set up by keyboard or Pc |
| Temperature range: | -10/+40°C |



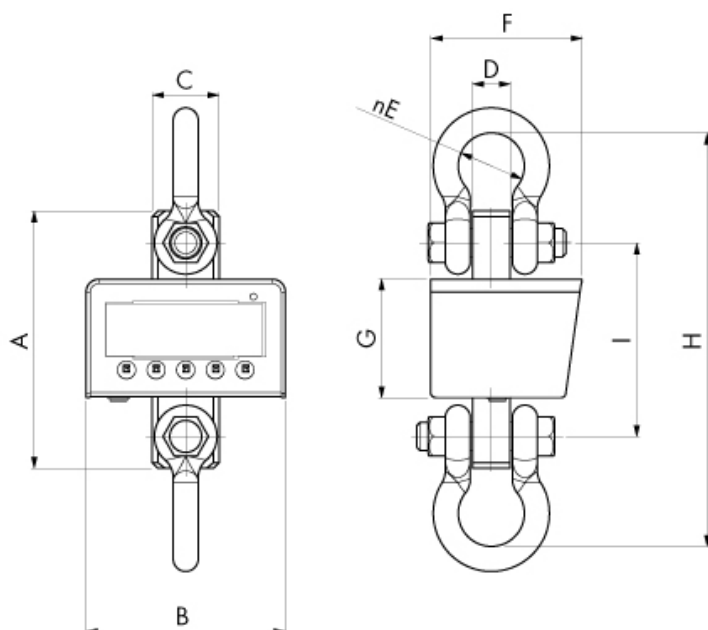

| MODEL | WEIGHT | A | B | C | D | E | F | G | H | I |
|---------|--------|-----|-----|----|----|----|-----|-----|-----|-----|
| CS05T1 | 6 | 193 | 175 | 49 | 24 | 44 | 133 | 104 | 330 | 153 |
| CS05T6 | 10 | 226 | 175 | 59 | 37 | 58 | 133 | 104 | 363 | 170 |
| CS05T11 | 15 | 246 | 175 | 80 | 46 | 74 | 133 | 104 | 430 | 180 |



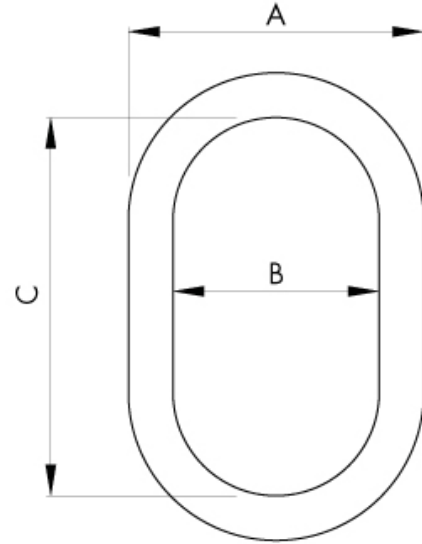
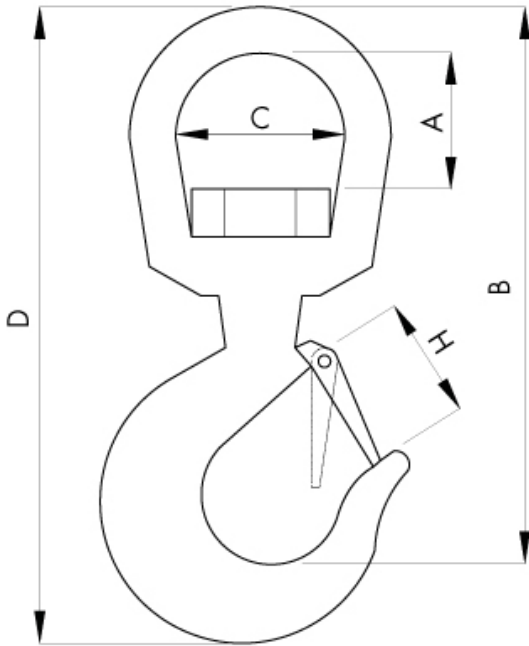

ACCESSORI OPZIONALI

| MODEL | RANGE | A | B | C | D | H |
|-------|-------|----|-----|----|-----|----|
| GG1T5 | 1.5 t | 53 | 164 | 47 | 207 | 30 |
| GG7 | 7 t | 84 | 315 | 90 | 410 | 48 |
| GG15 | 15 t | 95 | 354 | 96 | 455 | 63 |

| MODEL | RANGE | A | B | C |
|-------|-------|-----|-----|-----|
| CA2 | 2 t | 86 | 60 | 110 |
| CA8 | 8 t | 152 | 100 | 180 |
| CA15 | 15 t | 174 | 110 | 200 |



SCIGATE AUTOMATION (S) PTE LTD

No.1 Bukit Batok Street 22 #01-01 Singapore 659592

Tel: (65) 6561 0488

Fax: (65) 6562 0588

Email: sales@scigate.com.sg

Web: www.scigate.com.sg

Business Hours: Monday - Friday 8.30am - 6.15pm

