



**Solartron  
Metrology**

**SCIENCE  
GATE**  
Your Automation Partner



**SCIGATE AUTOMATION (S) PTE LTD**

No.1 Bukit Batok Street 22 #01-01 Singapore 659592

Tel: (65) 6561 0488

Fax: (65) 6562 0588

Email: sales@scigate.com.sg

Web: www.scigate.com.sg

Business Hours: Monday - Friday 8.30am - 6.15pm

# ANALOGUE BLOCK GAUGE



**user leaflet**

**AMETEK®**  
ULTRA PRECISION TECHNOLOGIES

# 1.0 Index

---

<b>Section</b>	<b>Title</b>	<b>Page</b>	<b>Section</b>	<b>Title</b>	<b>Page</b>
1.0	Index . . . . .	2	8.2	Mechanical . . . . .	18
2.0	Safety Summary . . . . .	3	8.3	Environmental . . . . .	18
3.0	Introduction . . . . .	4	8.4	Electrical Interface. . . . .	19
4.0	Components of the Block Gauge . . . . .	5	9.0	Connections . . . . .	20
5.0	Care of the Block Gauge . . . . .	7	9.1	Analogue Block Gauge . . . . .	20
6.0	Mechanical Installation . . . . .	8	10.0	Outline Drawings . . . . .	21
6.1	Tip Installation/Replacement . . . . .	9	10.1	Mechanical Drawings . . . . .	21
6.2	Tool Holder Installation/Adjustment . . . . .	10	10.2	Configuration Drawing . . . . .	24
6.3	Spring Installation/Adjustment . . . . .	11		Return of Goods	
6.4	Pneumatic Actuator Installation . . . . .	12		Solartron Sales Offices	
7.0	Maintenance . . . . .	13			
7.1	Sensor Replacement . . . . .	13			
8.0	Specifications . . . . .	15			
8.1	Measurement . . . . .	15			

## 2.0: Safety Summary

---

### Terms in this Handbook

**WARNING** statements identify conditions or practices that could result in personal injury or loss of life.

**CAUTION** statements identify conditions or practices that could result in damage to the equipment or other property.

### Symbols in this manual



This symbol indicates where applicable cautionary or other information is to be found.

### WARNINGS:

#### **Do not operate in an explosive atmosphere**

To avoid explosion, do not operate this equipment in an explosive atmosphere.

#### **Air Pressure**

Under no circumstances should the recommended maximum overpressure of 7 bar be exceeded when using pneumatics with the Block Gauge.

### NOTES:

#### **This equipment contains no user serviceable parts**

This equipment must be returned to your Solartron dealer for all servicing and repair.

### Low Voltage

This equipment operates at below the SELV and is therefore outside the scope of the Low Voltage Directive.

## 3.0: Introduction

---

The Block Gauge family makes precision measurements of bores and cavities a simple and reliable process. The use of these devices is ideal in applications where space is limited and where the use of axial probes is not possible.

Both digital and analogue versions of the Block Gauge are available, with measurement ranges of  $\pm 1$  mm,  $\pm 2.5$  mm or  $\pm 5$  mm.

The analogue versions can be used with standard conditioning electronics.

The digital versions are designed to be connected directly onto the Orbit Measurement Network, a modular system enabling fast and versatile connection of multiple probes.

## 4.0: Components of the 1mm Block Gauge

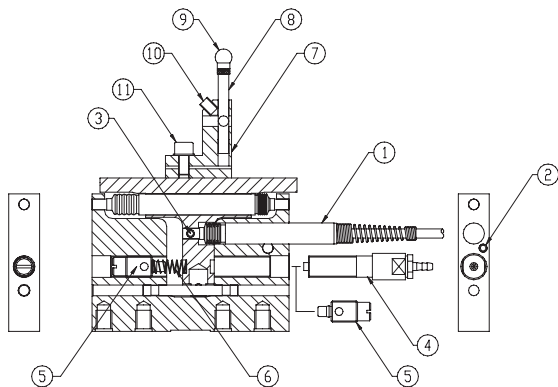

### Key

- 1 Sensor
- 2 Sensor Grub Screw
- 3 Sensor Grub Screw
- 4 Pneumatic Actuator
- 5 Spring Holder
- 6 Spring
- 7 Tool Holder
- 8 Tip Carrier
- 9 Tip
- 10 Tip Carrier Grub Screw
- 11 Caphead Screw

## 4.0: Components of the 2.5 & 5mm Block Gauge

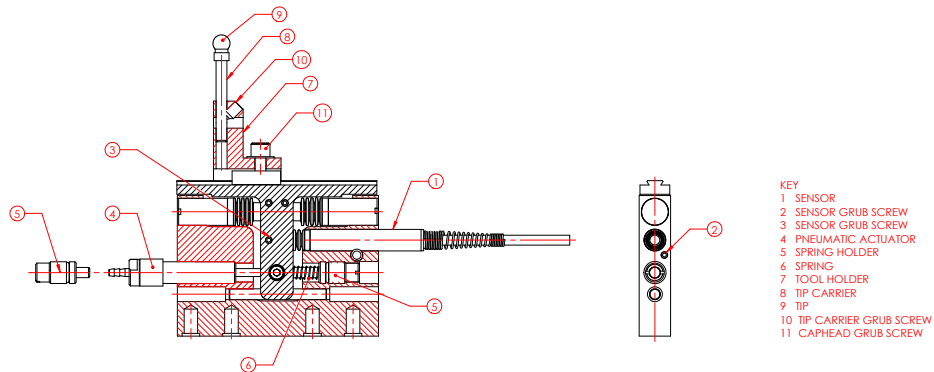

## 5.0: Care of the Block Gauge

---

The Block Gauge is a rugged parallel motion Universal Gauge designed to withstand the rigours of an industrial manufacturing environment. However, care should be taken during installation to avoid dropping the Block Gauge or subjecting it to severe shock loads.

In order to avoid damage to the linear bearings, it is important not to exceed the specified torque setting (1.5 to 2N m) of the fixing screw (11) when adjusting the tool holder (7).

The contact tip (9) should be fitted to the tip carrier (8) and tightened before the tip carrier is fitted to the tool holder. Tip carriers are available in 20 mm, 30 mm and 40 mm versions.

## 6.0: Mechanical Installation

First establish the orientation in which the Block Gauge will be used. The choice of return spring (6) and its position depends on the orientation of the gauge and should be made after the tool holder (7) and contact tip (9) have been fitted. A set of return springs (for different measurement forces) are included with each gauge.

It may be easier to set contact tip forces as close as possible to operating forces before the Block Gauge is installed onto a machine or fixture. Final adjustments may then be made after installation. Final adjustment of the spring force is made by winding the spring holder (5) in or out. (section 6.3)

When fitting a pneumatic actuator (4), ensure that the threads in the Block Gauge and the actuator are clean. In order to avoid damage to the actuator or the Block Gauge, it is important not to exceed the specified air pressure.

When mounting the Block Gauge in a fixture, care must be taken not to drop the gauge or apply excessive shocks which may degrade performance.

It should be secured by using the fixing screws at the base of the Block Gauge. The fixing screws are M6. The thread depth in the body is 8 mm.

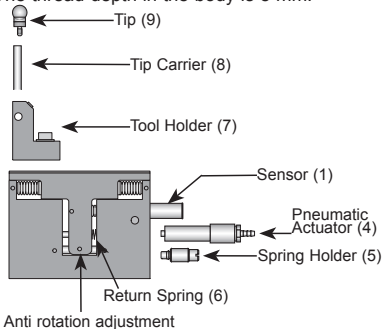

### CAUTION

The pneumatic Block Gauge generally works at a higher air pressure than pneumatic gauging probes (recommended pressure range 1 - 3 bar). In order to avoid damage to gauging probes when used in conjunction with Block Gauges, it is important that separate air pressure regulators are used for each product type.



## 6.0: Mechanical Installation (continued)

---

### 6.1: Tip Installation/Replacement

To avoid placing strain on the tool holder (7) and the Block Gauge frame, the tip carrier (8) should be removed from the tool holder before fitting or removing a tip (9).

The Block Gauge tool holder allows the Block Gauge tip and tip carrier to be mounted in one of three different planes for maximum flexibility.

### Tip Removal

1. Loosen the 2.5 mm tip carrier grub screw (10) which holds the tip carrier (8) in place.
2. Remove the tip carrier from the tool holder (7).
3. Unscrew the tip (9) from the end of the tip carrier.

### Tip Installation

1. Screw the tip (9) into the tip carrier (8).
2. Position the tip carrier in the tool holder (7).
3. Tighten the 2.5 mm tip carrier grub screw (10). Take care not to overtighten it.

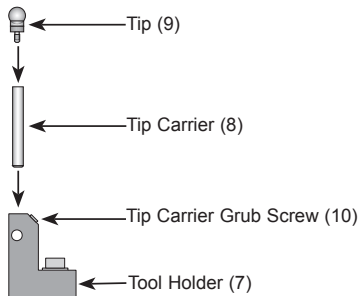

## 6.0: Mechanical Installation (continued)

### 6.2: Tool Holder Installation/Adjustment

The tool holder is infinitely adjustable along the industry standard dovetail fitting on the Block Gauge frame. This dovetail fitting ensures that the gauge is rigid yet easy to install and adjust.

#### Tool Holder Adjustment

1. Loosen the caphead screw (11) located on the tool holder (7) using a 3 mm Allen key.
2. Slide the tool holder to the required position.
3. Tighten the screw.



#### CAUTION

In order to avoid damage to the linear bearings, it is important not to exceed the specification for the torque setting (1.5 to 2 Nm) of the fixing screw when adjusting the tool holder.

#### Tool Holder Installation

To remove the tool holder (7), loosen the caphead screw (11) located on the tool holder using a 3 mm Allen key. Slide the tool holder off the dovetail.

To re-install the tool holder, simply slide it over the dovetail joint to the required position and then tighten the caphead screw.

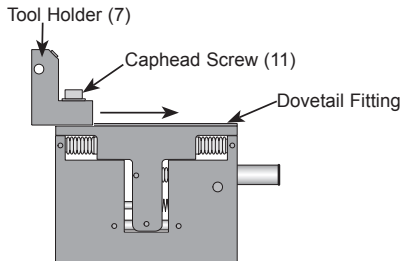

## 6.0: Mechanical Installation (continued)

### 6.3: Spring Installation/Adjustment

The choice of spring return and its position depends on the orientation of the gauge and should be made after the tool holder and contact tip have been fitted. (See section 6.2). A set of four return springs are included with each gauge.

1. Unscrew and remove the spring holder (5) or pneumatic actuator (4) if this was being used.

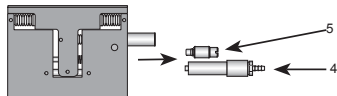

2. Remove the spring (6) if installed.

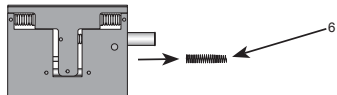

3. Select an appropriate spring, and insert this into the frame.

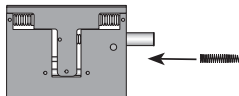

4. Insert the screw holder back into the Block Gauge frame and screw in.

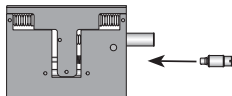

5. Final adjustment to the spring force is made by winding the spring holder in or out using a flat blade screwdriver.

Refer to section 10.2 for information on the configuration of the spring and pneumatic actuator.

## 6.0: Mechanical Installation (continued)

### 6.4: Pneumatic Actuator Installation

1. Unscrew and remove the spring holder (5).

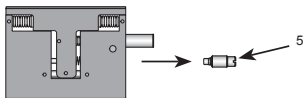

2. Remove the spring (6) if it is installed.

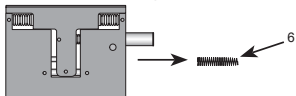

3. Install a spring and spring holder opposite to where the pneumatic actuator is to be installed (section 6.3).
4. Insert the pneumatic actuator (4) and screw until tight. Do not overtighten.

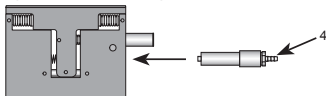

To maximise the working life of the Block Gauge, the air supply should be both clean and dry for continual reliable operation. The air should have a maximum relative humidity of 60% RH and be filtered to better than 5  $\mu\text{m}$  particle size.

When fitting a pneumatic actuator, ensure that threads in the Block Gauge and the actuator are clean. In order to avoid damage to the actuator or the Block Gauge, it is important not to exceed the specification for air pressure.



#### CAUTION

The pneumatic Block Gauge generally works at a higher air pressure than pneumatic gauging probes (recommended pressure range 1 - 3 bar). In order to avoid damage to gauging probes when used in conjunction with Block Gauges, it is important that separate air pressure regulators are used for each product type.

# 7.0: Maintenance

## 7.1 Sensor Replacement - Analogue Version Only

### Sensor Removal

1. Loosen the two sensor grub screws (2 & 3) which hold the sensor (1) in place.
2. Gently ease the sensor away from the frame. Care must be taken not to damage the core or the gaiter during removal.

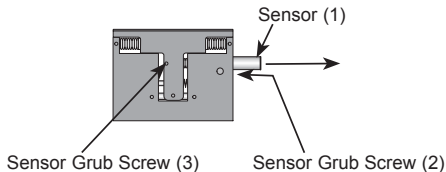

### Sensor Installation

1. Insert the replacement sensor (1) into the Block Gauge frame. Care must be taken not to damage the core or the gaiter during insertion. The carrier must not protrude from the T-piece.
2. Tighten sensor grub screw (3), but leave screw (2) loose.
3. Adjust the spring holder (5) opposite the sensor so that there is a small gap of approximately 0.25 mm between the T-piece and the frame (see below).

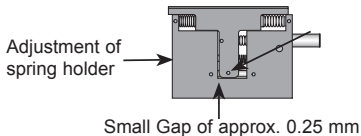

## 7.0: Maintenance (continued)

---

4. Connect an oscillator supply to the sensor.
5. Monitor the output of the sensor on a DVM.
6. Move the T-piece in by the pre-travel (typically 0.15 mm) + rated stroke. The T-piece must remain fixed in this position during the setting of electrical null.
7. Adjust the position of the sensor relative to the frame to achieve minimum output on the DVM. Care should be taken not to rotate the sensor during this adjustment. This is electrical null.
8. Tighten sensor grub screw (2).

# 8.0: Specifications

## 8.1: Measurement

		<b>Analogue</b>		
<b>Measurement Range (mm)</b>		$\pm 1.0$	$\pm 2.5$	$\pm 5.0$
<b>Mechanical Travel (mm)</b>		3 mm	6 mm	11 mm
<b>Accuracy<sup>(1)</sup></b>	$\pm 1.0$ mm $\pm 2.5$ mm $\pm 5.0$ mm	$\pm 1.0 \mu\text{m}$ or $\pm 0.5\% \times D$ $\pm 2.5 \mu\text{m}$ or $\pm 0.5\% \times D$ $\pm 5.0 \mu\text{m}$ or $\pm 0.5\% \times D$ (whichever the greater) at 5 kHz for LVDT, at 10 kHz for half bridge		
<b>Repeatability (on-axis at 70 g tip force)</b>	$\pm 1.0$ mm $\pm 2.5$ mm $\pm 5.0$ mm	$0.25 \mu\text{m}$ $0.25 \mu\text{m}$ $0.50 \mu\text{m}$		
<b>Resolution</b>		Dependent on Electronics		
<b>Null Position</b>		Adjustable		
<b>Tip Force<sup>(2)</sup></b>	$\pm 1.0$ mm $\pm 2.5$ mm $\pm 5.0$ mm	0.75 N minimum		
<b>Temperature Coefficient</b>	$\pm 1.0$ mm $\pm 2.5$ mm $\pm 5.0$ mm	$\pm 0.2 \mu\text{m}/^\circ\text{C}$ $\pm 0.5 \mu\text{m}/^\circ\text{C}$ $\pm 1.0 \mu\text{m}/^\circ\text{C}$		
<b>Life</b>		Better than 5 million measuring cycles (dependent on application)		

## 8.0: Specifications (continued)

---

Accuracies quoted are through the gauge centreline.

Unplugged (free lead) and other specification available on request.

(1) Accuracy includes both linearity and sensitivity errors (D is the distance from setting master).

(2) Maximum tip force is 3.5 N. A selection of springs can be supplied for attitude and dead weight compensation. Care should be taken as the probe performance (accuracy and repeatability) may degrade at high tip forces.



## 8.0: Specifications (continued)

---

### 8.1: Measurement

Note 1: The linearity specification includes errors due to both linearity and sensitivity. Other manufacturers may quote these errors separately. These linearity specifications are substantially more demanding than the 0.25% full scale conventionally specified, as shown in the diagram below.

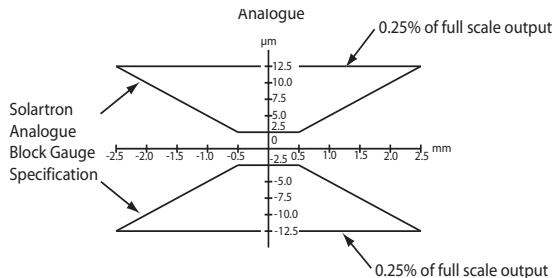

Note: Example is for  $\pm 2.5$  mm Block Gauge

## 8.0: Specifications (continued)

### 8.2: Mechanical

		<b>Analogue</b>	
<b>Mass (g / lbs)</b> (Without toolholder)	<b>±1.0 mm</b>	160 g (0.352 lbs)	
	<b>±2.5 mm</b>	390 g (0.858 lbs)	
	<b>±5.0 mm</b>	385 g (0.847 lbs)	
<b>Mass of moving parts (g / lbs)</b>	<b>±1.0 mm</b>	35 g (0.077 lbs)	
	<b>±2.5 mm</b>	90 g (0.198 lbs)	
	<b>±5.0 mm</b>	95 g (0.209 lbs)	
<b>Material</b>	Stainless Steel (300 Series) with Fluoroelastomer Gaiters		
<b>IP Rating</b>	IP65		IP65 IP43 for electronics
<b>Operating Pressure</b>	1 bar to 3 bar		

### 8.3: Environmental

	<b>Analogue</b>
<b>Storage Temperature (°C)</b>	-40 to +85
<b>Operating Temperature (°C)</b>	+5 to +85
<b>Shock</b>	To maintain best performance, the Block Gauge should be protected from excessive shock loads and dropping

## 8.0: Specifications (continued)

---

### 8.4: Electrical Interface

		Analogue		
		LVDT	Half Bridge	
<b>Energising Voltage</b>		1 to 10 Vrms		
<b>Energising Frequency</b>		2 to 20 kHz		
<b>Energising Current</b>		2 mA/V at 5 kHz	2 mA/V at 10 kHz	
<b>Calibration Voltage</b>		3 V		
<b>Calibration Frequency</b>		5 kHz	10 kHz	
<b>Calibration Load</b>		10 K $\Omega$	2 K $\Omega$	
<b>Sensitivity (mV/V/mm)</b>	$\pm 1.0$ mm	200 $\pm 0.5\%$	73.5 $\pm 0.5\%$	
	$\pm 2.5$ mm	80 $\pm 0.5\%$	29.4 $\pm 0.5\%$	
	$\pm 5.0$ mm	40 $\pm 0.5\%$ at 5 kHz	14.7 $\pm 0.5\%$ at 10 kHz	

Note: Operation outside of calibration voltage, frequency and load may degrade performance.

# 9.0: Connections

## 9.1: Analogue Block Gauge

### LVDT Electrical Connections

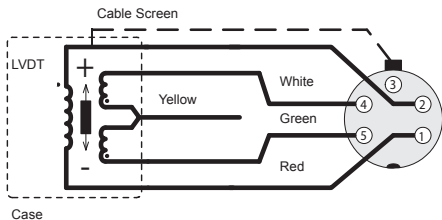

Note: + indicates forward movement of the tip.

LVDT Electrical Connections	
Red & Blue	Energising
Green & White	Signal
Yellow	Secondary Centre Tap
Red & White	In Phase for Inward Displacement

### Half Bridge Electrical Connections

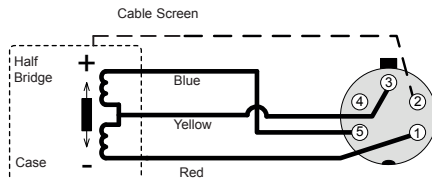

Note: + indicates forward movement of the tip.

Half-Bridge Electrical Connections	
Red & Blue	Energising
Yellow	Signal
Red & Yellow	In Phase for Inward Displacement
Screen	Transducer Body Ground

# 10.0: Outline Drawings

## 10.1: Mechanical Drawings

2 mm Block Gauge  
eg BG/1/S

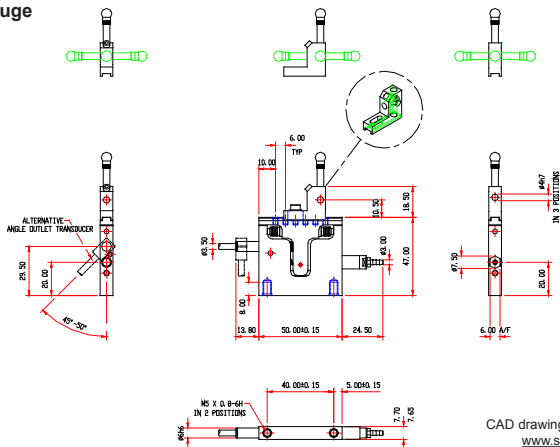

CAD drawings can be downloaded from  
[www.solartronmetology.com](http://www.solartronmetology.com)

# 10.0: Outline Drawings (continued)

## 10.1: Mechanical Drawings

5 mm Block Gauge  
eg BG/2.5/S

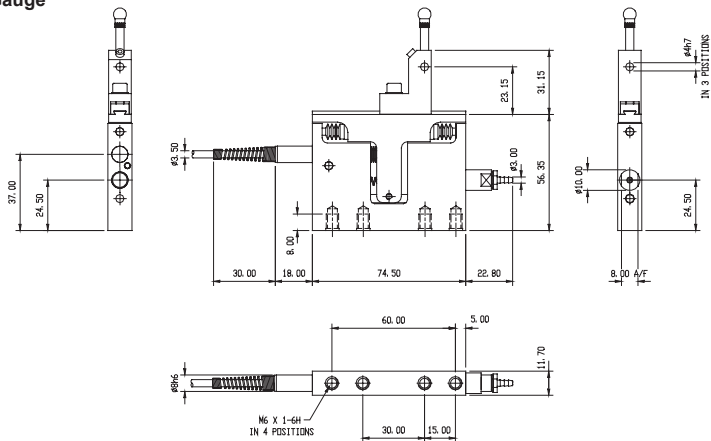



# 10.0: Outline Drawings (continued)

## 10.2: Configuration Drawing

