



**Solartron
Metrology**

**SCIENCE
GATE**
Your Automation Partner



SCIGATE AUTOMATION (S) PTE LTD

No.1 Bukit Batok Street 22 #01-01 Singapore 659592

Tel: (65) 6561 0488

Fax: (65) 6562 0588

Email: sales@scigate.com.sg

Web: www.scigate.com.sg

Business Hours: Monday - Friday 8.30am - 6.15pm

DIGITAL FLEXURE



user leaflet

AMETEK[®]
ULTRA PRECISION TECHNOLOGIES

Index

Section	Title	Page
1.0	Index	1
2.0	Safety Summary	2
3.0	Flexure	3
4.0	Mechanical Installation	4
5.0	Specifications	5

Return Of Goods
Solartron Sales Offices

2.0: Safety Summary

Terms in this Manual

WARNING statements identify conditions or practices that could result in personal injury or loss of life.

CAUTION statements identify conditions or practices that could result in damage to the equipment or other property.

Symbols in this manual



This symbol indicates where applicable cautionary or other information is to be found.

WARNINGS:

Do not operate in explosive atmosphere

To avoid explosion, do not operate this equipment in an explosive atmosphere.

Air Pressure

Under no circumstances should the recommended maximum overpressure of 7 bar be exceeded when using pneumatics with the Flexure.

NOTES:

This equipment contains no user serviceable parts

This equipment must be returned to your original supplier for all servicing and repair.

Low Voltage

This equipment operates at below the SELV and is therefore outside the scope of the Low Voltage Directive.

3.0: Flexure

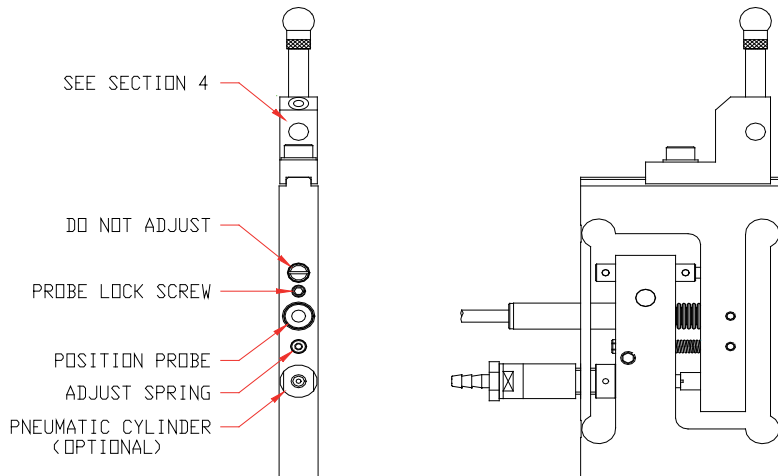

4.0: Mechanical Installation

4.1: Tip Installation / Replacement

To avoid placing strain on the tool holder (7) and the Flexure frame, the tip carrier (8) should be removed from the tool holder before fitting or removing a tip (9).

The Flexure tool holder allows the Flexure tip and tip carrier to be mounted in one of three different planes for maximum flexibility

Tip Removal

Loosen the 2 mm A/F tip carrier grub screw (10) which holds the tip carrier (8) in place.

1. Remove the tip carrier from the tool holder (7).
2. Unscrew the tip (9) from the end of the tip carrier.

Tip Installation

1. Screw the tip (9) into the tip carrier (8).
2. Position the tip carrier in the tool holder (7).
3. Tighten the 2 mm A/F tip carrier grub screw (10). Take care not to overtighten it.

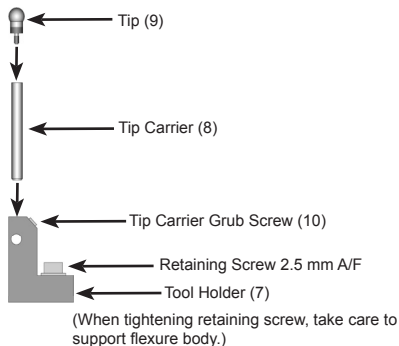

5.0: Specification - See Orbit3 Catalogue

For instruction on using Orbit3 see the Orbit3 System Manual supplied on the Orbit3 Support Pack for Windows CD