

SPRING PUSH STANDARD BG/5/S & DK/10/S AT MIDRANGE USING ϕ 8mm TRANSDUCER WITH AXIAL CABLE OUTLET

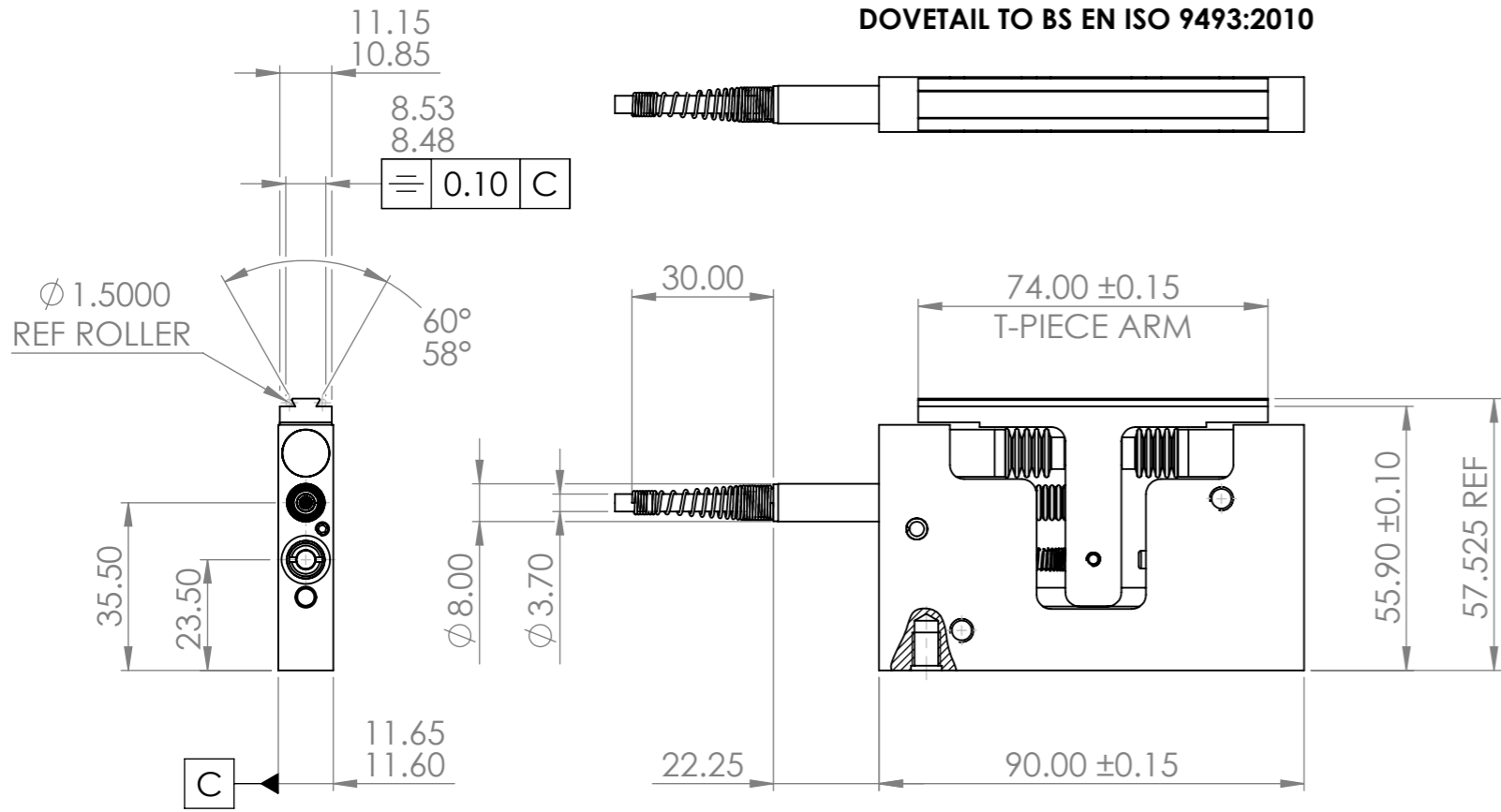

SPRING PUSH STANDARD BGR/5/S & DKR/10/S AT MIDRANGE USING ϕ 8mm TRANSDUCER WITH RADIAL CABLE OUTLET

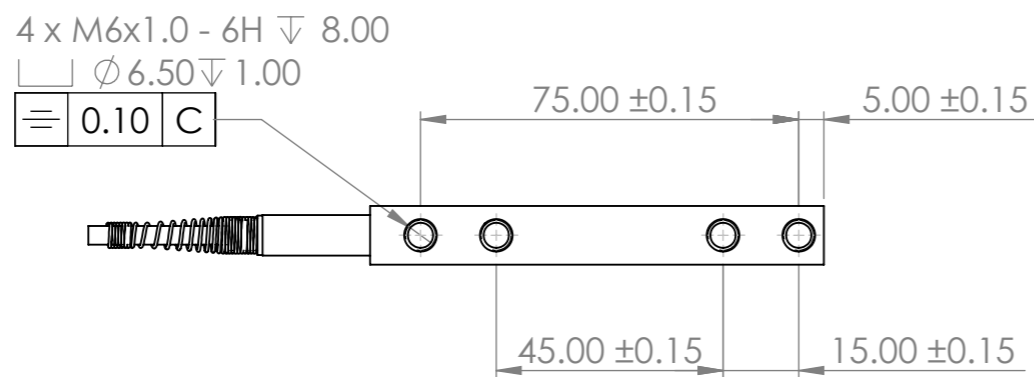
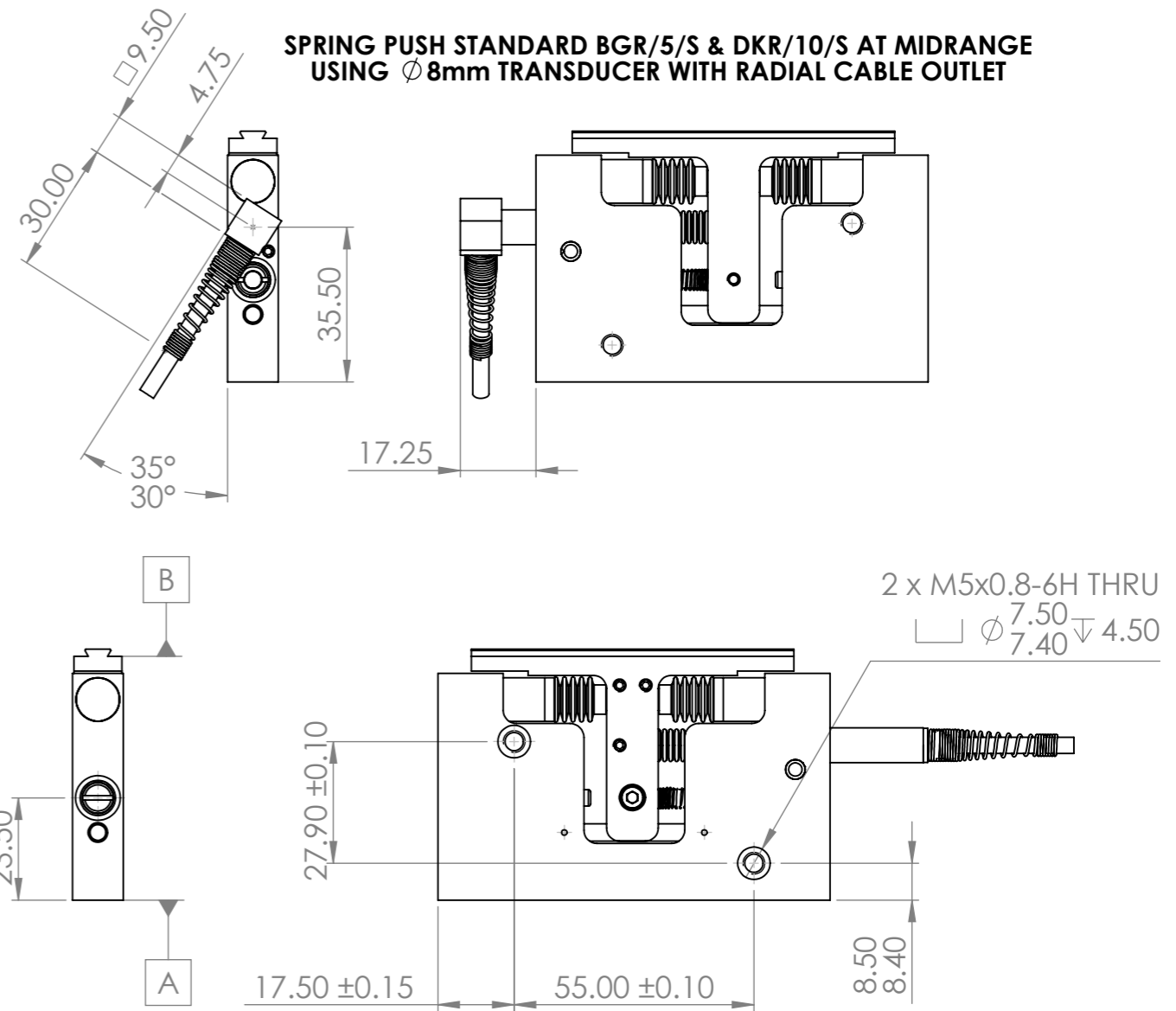

SPRING PUSH STANDARD BG/5/P & DK/10/P AT MIDRANGE USING ϕ 8mm TRANSDUCER WITH AXIAL CABLE OUTLET

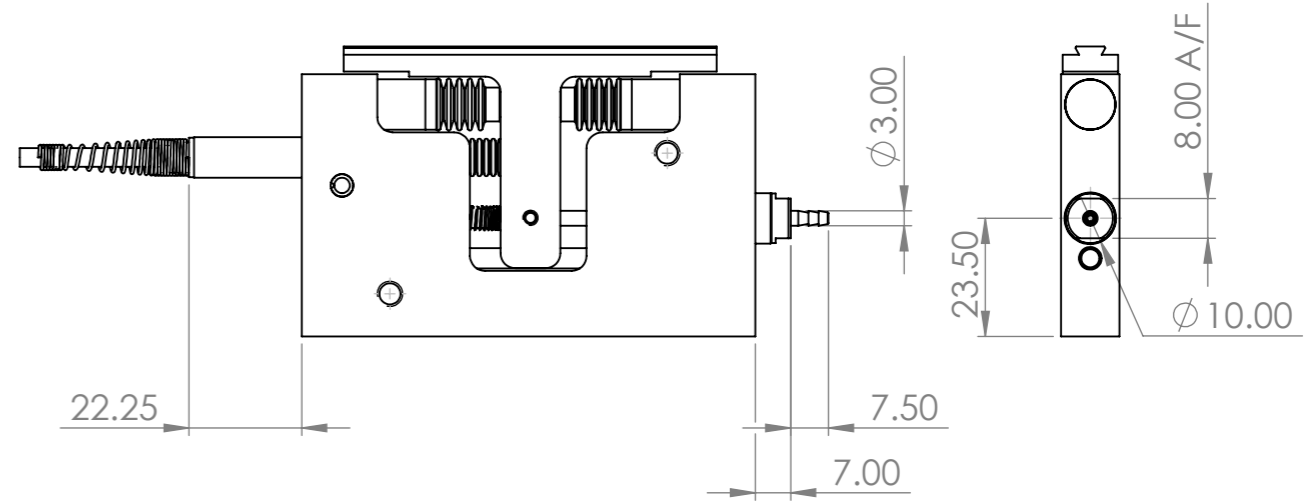

- NOTES:-
1. ALL BLOCK GAUGE PRODUCTS ARE SHOWN IN THE REST POSITION.
 2. FOR ALL PRODUCTS WITH RIGHT ANGLE CABLE OUTLET AND MANUFACTURER FITTED PNEUMATIC CYLINDER, TRANSDUCER LEAD OUT ANGLE IS 30°-35°, EXCEPT REVERSED BLOCK GAUGES.
 3. FOR ALL PRODUCTS WITH RIGHT ANGLE CABLE OUTLET AND RETROFIT PNEUMATIC CYLINDERS, BOTH SIDE ACCESS, OR FROM TRANSDUCER SIDE ONLY, TRANSDUCER LEAD OUT ANGLE IS 45°-50°.

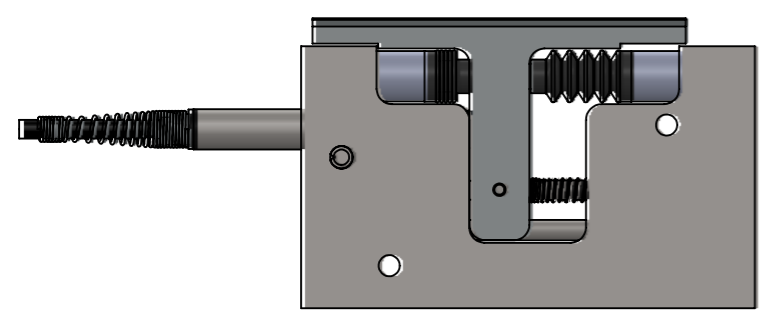

**BG/5/R(H) OR DK/10/R
REVERSED ACTION**

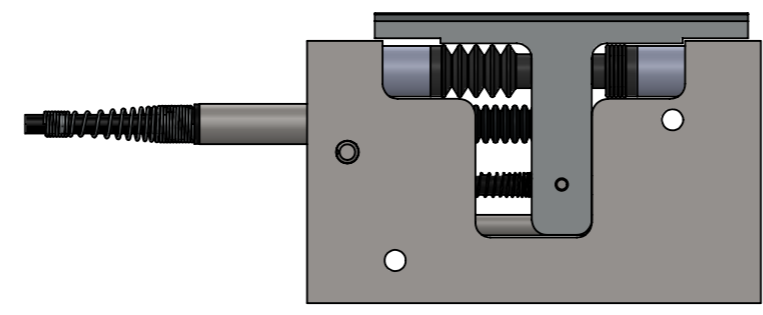

**BG/5/S(H) OR DK/10/S
STANDARD**

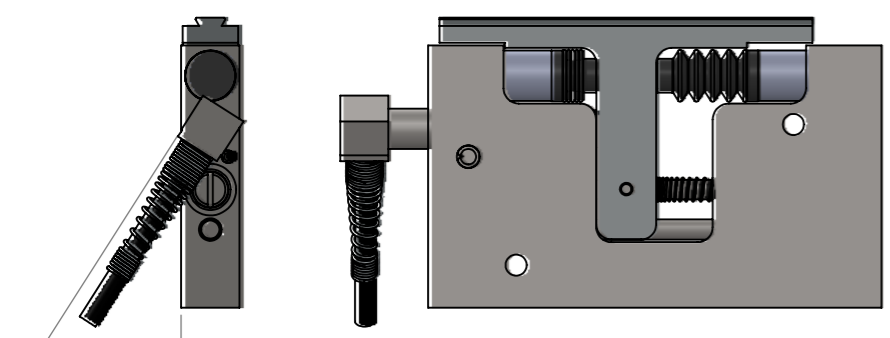

**BGR/5/R(H) OR DKR/10/R
REVERSED ACTION**

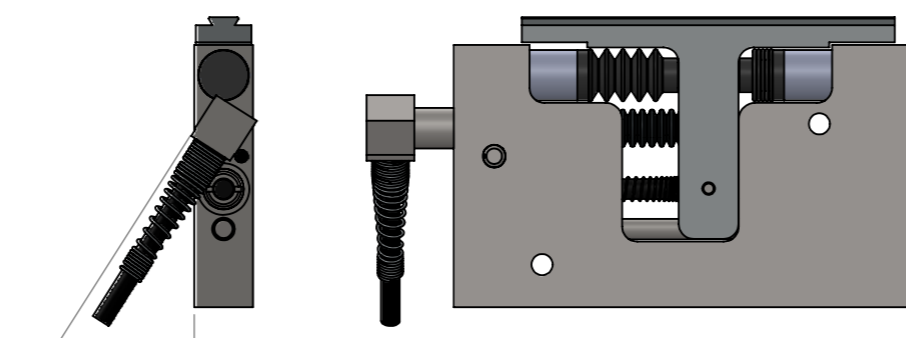

**BGR/5/S(H) OR DKR/10/S
STANDARD**

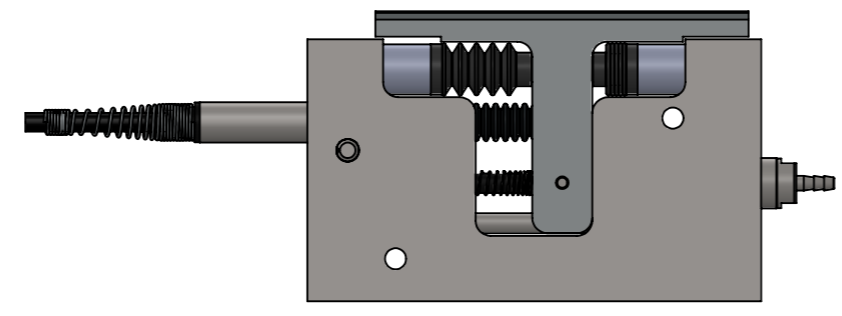
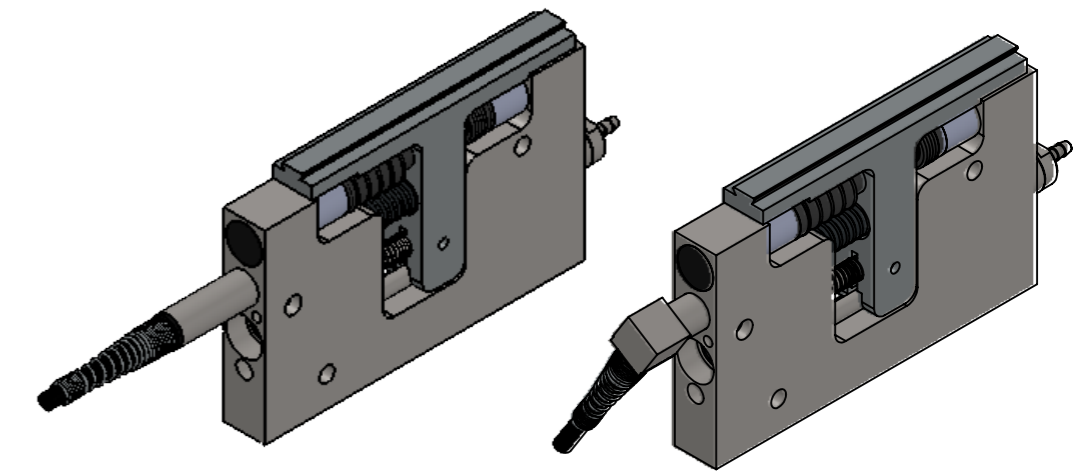

**BG/5/P(H) OR DK/10/P
STANDARD**

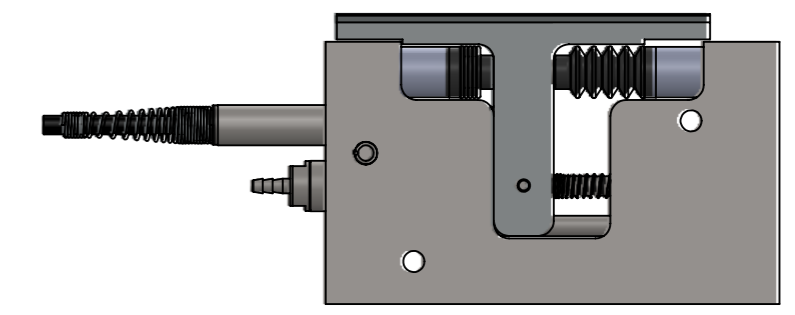

**BG/5/RP(H) OR DK/10/RP
REVERSED ACTION**

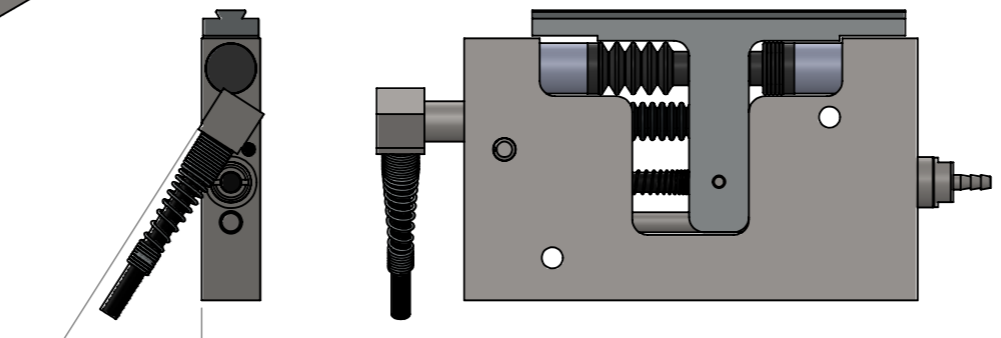
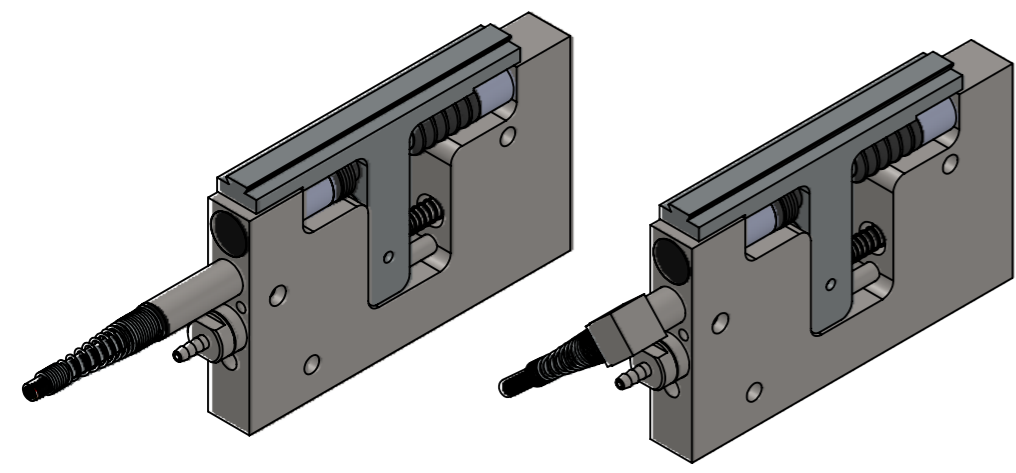

**BGR/5/P(H) OR DKR/10/P
STANDARD**

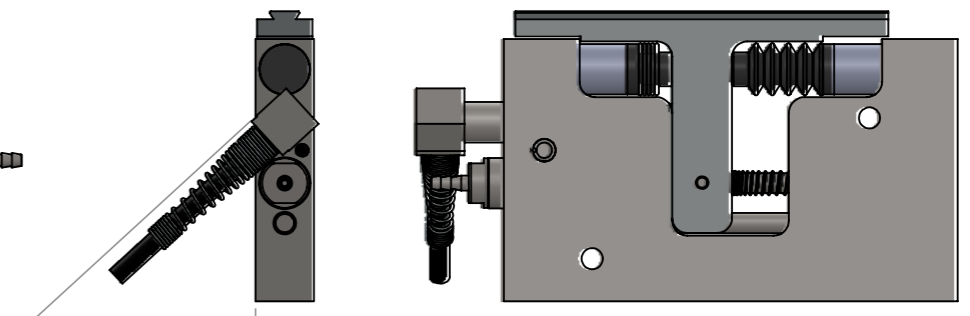

**BGR/5/R(H) OR DKR/10/RP
REVERSED ACTION**



STEYNING WAY • BOGNOR REGIS • SUSSEX • ENGLAND • PO22 9ST

DRAWING NUMBER
540002-081

TITLE
**BLOCK GAUGE
BG/5 & DK/10**

E.D.C.R.
ISSUE

22692
6

SOLARTRON PURSUES A POLICY OF CONTINUOUS DEVELOPMENT. SPECIFICATIONS IN THIS DOCUMENT MAY THEREFORE BE CHANGED WITHOUT NOTICE. DIMENSIONS ARE NOMINAL AND SPECIFIED IN MILLIMETRES

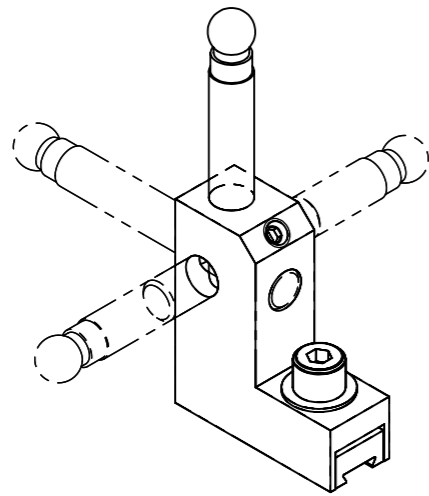

804798-SX TOOL HOLDER ASSY BG/5 & DK/10 - ϕ 6mm - DOVETAIL
 DOVETAIL TO BS EN ISO 9493:2010
 TIP & TOOL HOLDER SHOWN FOR ALTERNATIVE POSITION ONLY

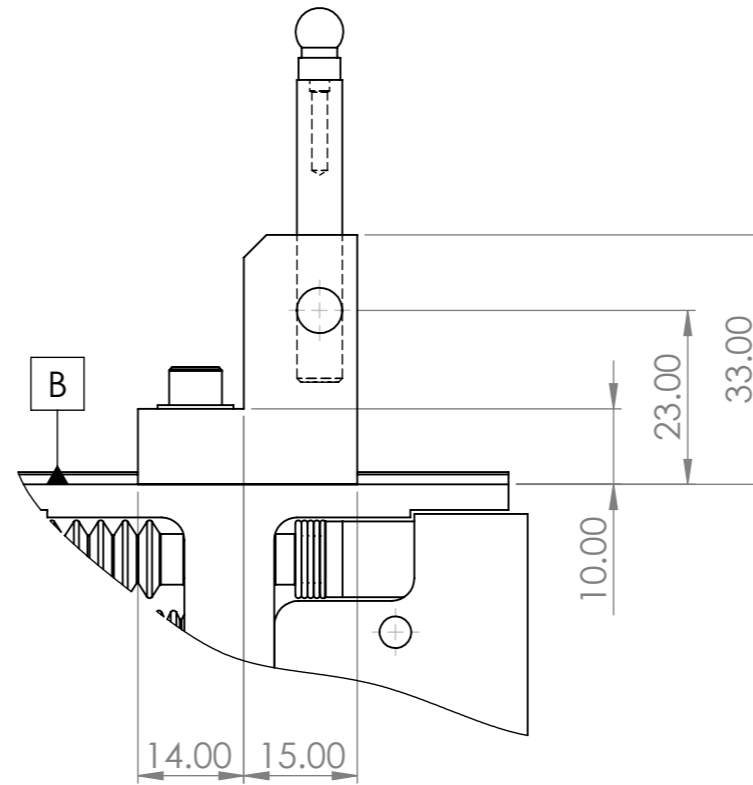

TOOL HOLDER -ASSEMBLED

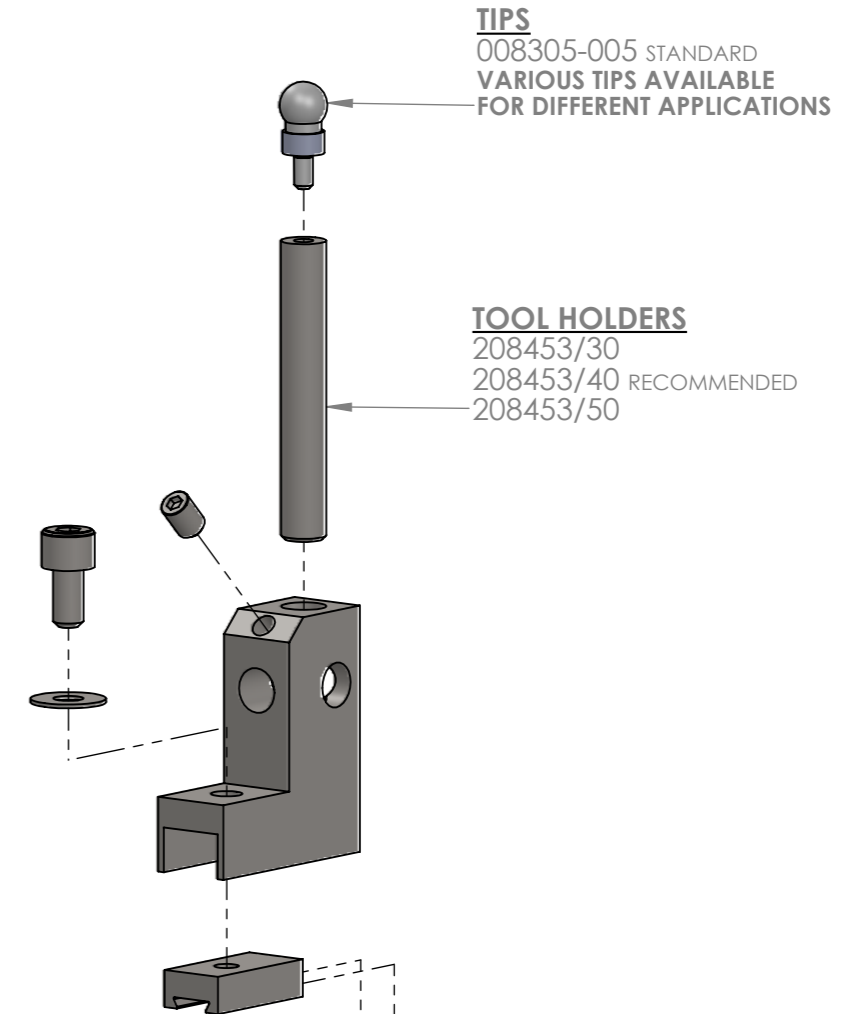

TIPS
 008305-005 STANDARD
 VARIOUS TIPS AVAILABLE
 FOR DIFFERENT APPLICATIONS

TOOL HOLDERS
 208453/30
 208453/40 RECOMMENDED
 208453/50

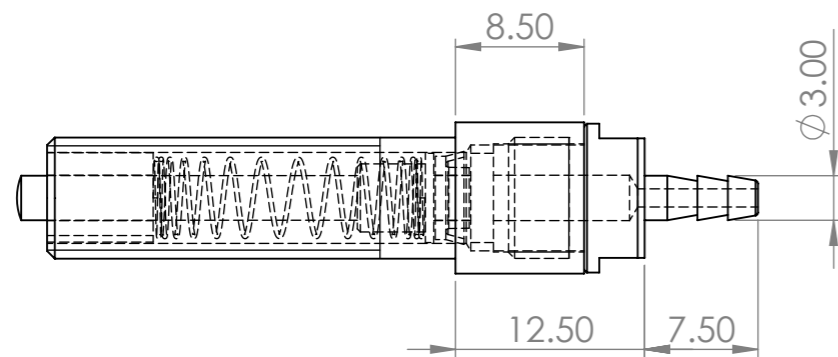

805493-SX CYLINDER M8x0.75-6g WITH SPRING RETURN

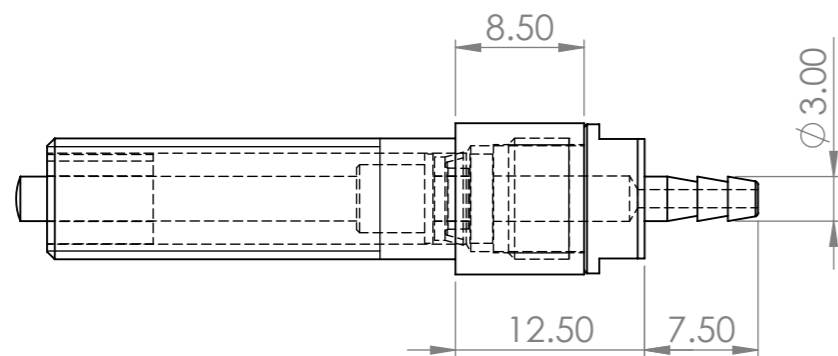
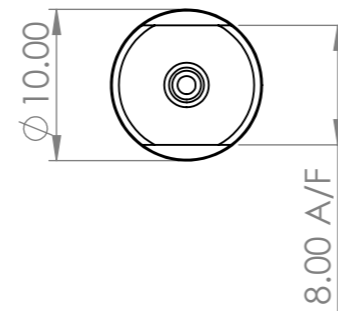

805490-SX CYLINDER M8x0.75-6g

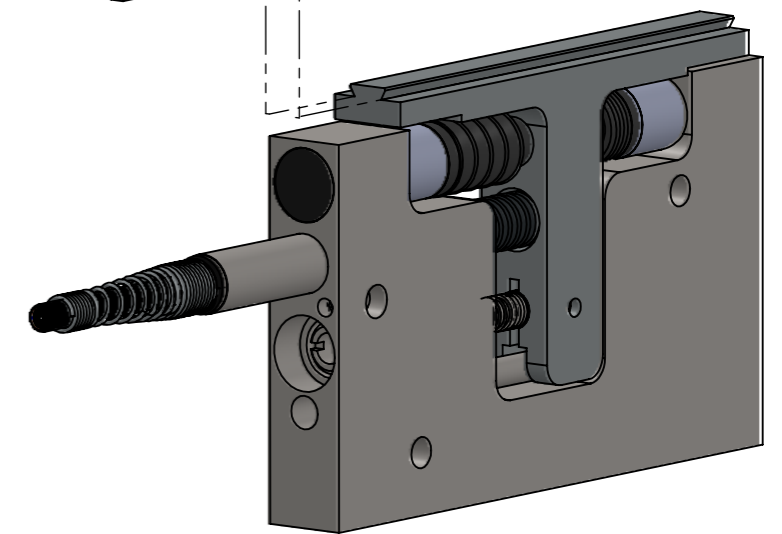
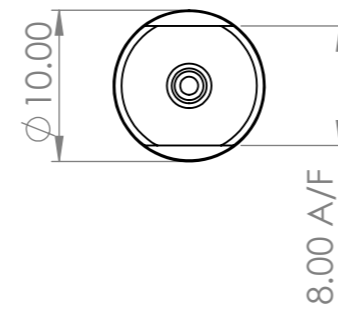

BLOCK GAUGE ACCESSORIES

 STEYNING WAY • BOGNOR REGIS • SUSSEX • ENGLAND • PO22 9ST	DRAWING NUMBER	TITLE	E.D.C.R.	22692
	540002-081	BLOCK GAUGE BG/2.5 & DK/5	ISSUE	6
SOLARTRON PURSUES A POLICY OF CONTINUOUS DEVELOPMENT. SPECIFICATIONS IN THIS DOCUMENT MAY THEREFORE BE CHANGED WITHOUT NOTICE. DIMENSIONS ARE NOMINAL AND SPECIFIED IN MILLIMETRES				