

## Product Features:

- Compatible with M101B, M101H, and M101BT
- Easy installation
- High capacity battery for long-life operating

## Mechanical Drawing

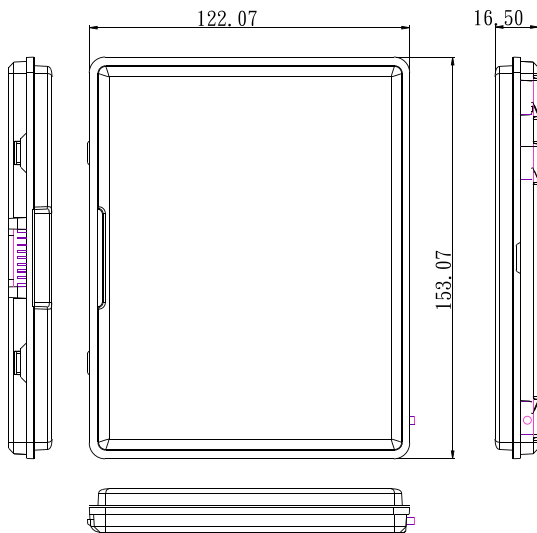

Dimensions	153 x 122 x 16.5 mm
Weight	474 g
Color	Pantone# 8403C



**SCIGATE AUTOMATION (S) PTE LTD**  
 No.1 Bukit Batok Street 22 #01-01 Singapore 659592  
 Tel: (65) 6561 0488 Fax: (65) 6562 0588  
 Email: sales@scigate.com.sg Web: www.scigate.com.sg  
 Business Hours: Monday - Friday 8.30am - 6.15pm

## Installation Procedure

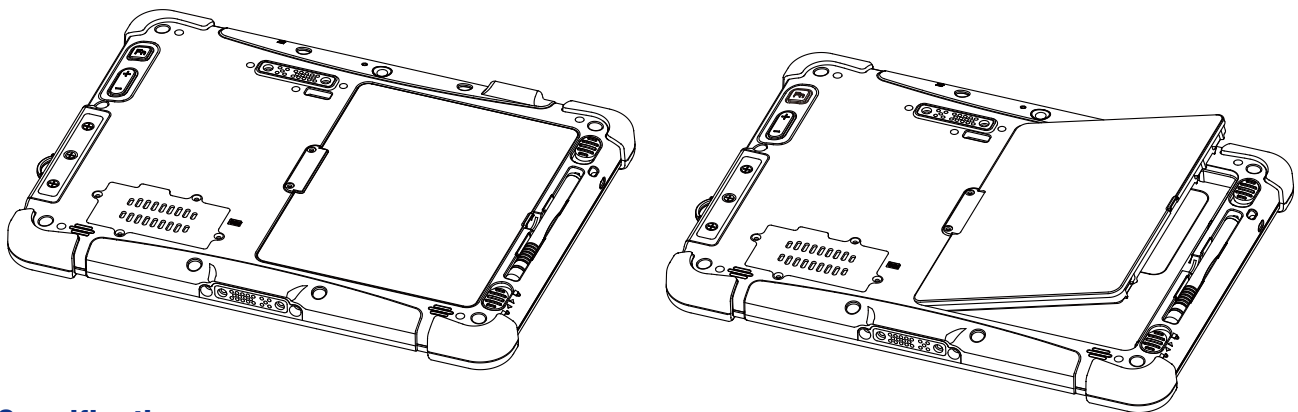

## Specification

Voltage / Capacity	7.4V / typ. 10280 mAh
Composition	2S2P Li-Polymer Re-chargeable Battery
Operating Temperature	Standard Charging: 0~45°C Standard Discharging : -20~60°C
Life Cycle	≥ 300
Certification	UL2054, IEC62133, UN38.3