

# Hotswap Battery for M700D

HB-M70M

## Product Features:

- Tool-less Hand Screw for Easy and Secure Installation or Removal of Battery
- Large Capacity for Extended Battery Life
- Battery Installs Seamlessly and Securely to M700D to Be a Complete Unit

## Mechanical Drawing

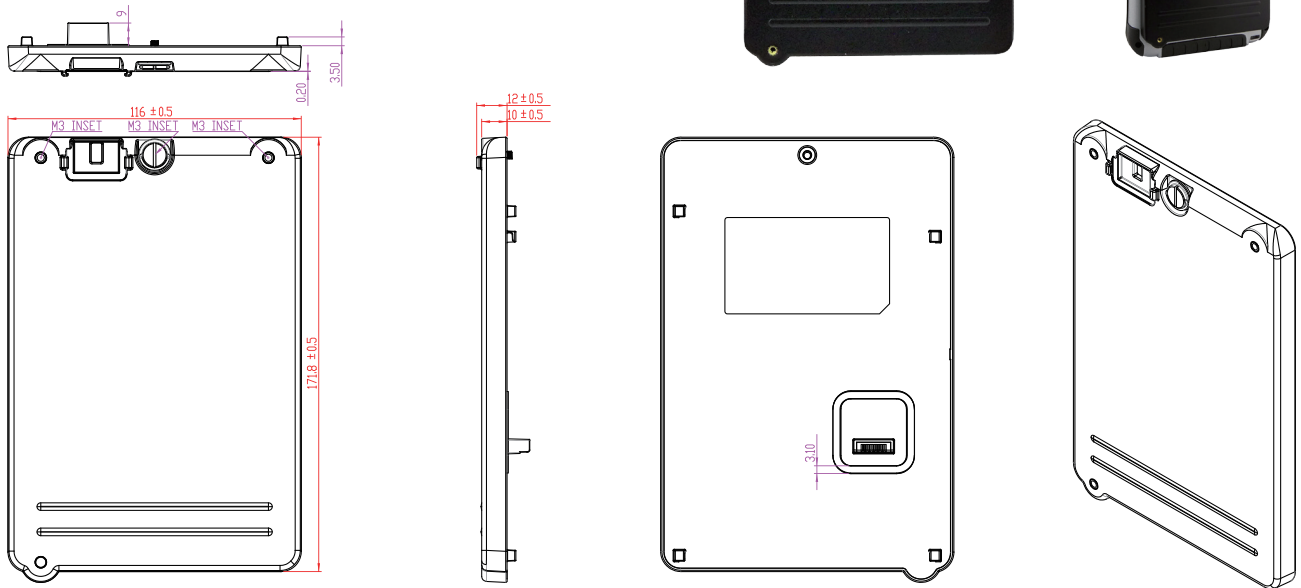

## Installation Procedure

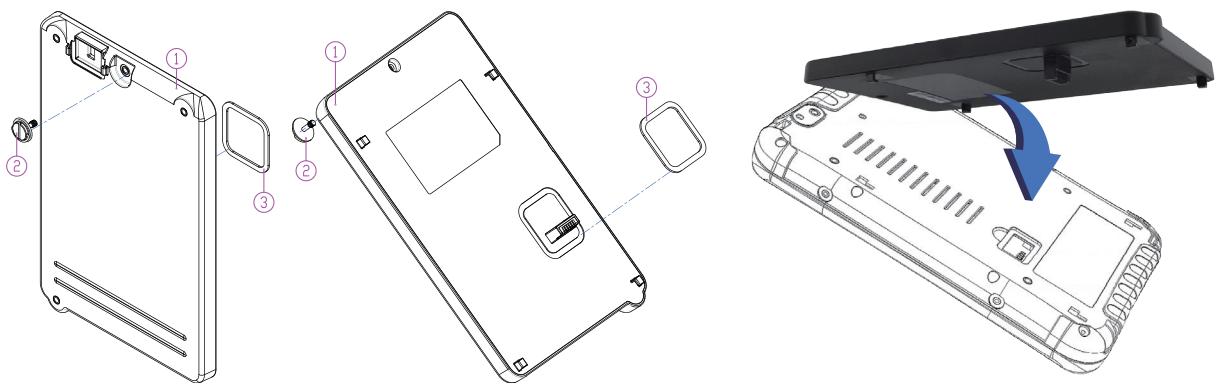

## Specification

Dimension	189 x 116 x 10mm
Voltage / Capacity	7.4V 5300mAh
Composition	2S1P LiIon rechargeable battery
Life cycle	≥ 300
Certification	UN38.3

**SCIGATE**  
Your Automation Partner



SCIGATE AUTOMATION (S) PTE LTD  
No.1 Bukit Batok Street 22 #01-01 Singapore 659592  
Tel: (65) 6561 0488 Fax: (65) 6562 0588  
Email: sales@scigate.com.sg Web: www.scigate.com.sg  
Business Hours: Monday - Friday 8.30am - 6.15pm

**WINMATE** ///

www.winmate.com.tw