

10.1" Rugged Tablet PC

M101H

Product Features:

- 10.1" 1920x1200 IPS LED Panel with P-Cap Touch
- Sunlight Readable Display
- High-performance system with Intel Core i5-5200U Broadwell 2.2GHz (turbo to 2.7GHz)
- IP65 water and dust proof
- Optional 1D/2D Barcode Reader
- Dual Camera Design: 5MP Main camera with LED flash / 2MP Webcam
- Optional Expansion port for USB / RS232 connection
- Hot-Swappable Battery Design / Optional high capacity battery pack
- 2 Programmable function keys
- With Optical Bonding for Sunlight Readability



CE FCC

Product Specifications:

System Specification	Processor	Intel Core i5-5200U Broadwell 2.2GHz (turbo to 2.7GHz)
	System Memory	4GB SODIMM DDR3L-1600 (up to 8GB)
	Storage	64GB mSATA MLC SSD (up to 256GB)
	Operating System	Windows 10 IoT Enterprise / Windows Embedded 8.1 Industry Pro / Windows Embedded Standard 7 (WS7P) / Windows 7 Pro for Embedded Systems
Display Specification	Size / Technology	10.1-inch IPS LED backlight
	Resolution	1920 x 1200 WUXGA
	Brightness	700 nits typ. With Optical Bonding for Sunlight Readability
	Touch	Multi-Touch Projective Capacitive
	Contrast Ratio	800:1
	Viewing Angle	89 / 89 / 89 / 89
Wireless Communication	WLAN	802.11 a/b/g/n
	Bluetooth	Bluetooth 4.0 Dual Mode (Classic + Low Energy) Class I
	GPS	u-Blox Neo-6Q
	WWAN	Optional 4G (LTE,HSPA+,GSM/GPRS/EDGE,EV-DO Rev A, 1xRTT) or optional 3G (HSPA+,GSM/GPRS/EDGE)
System I/O Buttons Indicators Sensors	Audio	2 x 1W Speaker
	External I/O	1 x Micro HDMI, 1 x 30-pin Combo Conn (LAN or RS232), 1 x USB3.0, 1 x Audio Combo Conn. (Mic in / Line Out), 1 x Power Jack, 1 x Micro SD Slot
	Buttons	1 x Power, 1 x Home, 1 x Function Key, 2 x Volume Key
	LED Indicators	Power / Battery / HDD/ RF
	Sensors	Light sensor/ G sensor / Gyrometer/ E-compass
Security	Security	Password security for user and hard disk lock Trusted platform module (TPM) V1.2
	Mobile Device Management	SOTI MobiControl compatible
Data Capture	Camera	5MP Auto-Focus Camera with LED Flash at rear 2MP Camera at front side
	Barcode	Short Range 1D/2D Barcode Reader (optional)
Mechanical and Environment	Dimension (W x L x H)	271.8 x 197.2 x 21 mm (10.7 x 7.76 x 0.83 inches)
	Weight	1.25 kg (2.7 lbs) with standard battery, 1.45 kg (3.2 lbs) with optional high capacity battery
	Operating Temperature	-20°C to 60°C (AC mode), -10°C to 50°C (Battery mode)
	Storage Temperature	-30°C to 70°C (-22°F to 158°F)
	Humidity	10% to 90% RH, non-condensing
	IP Proof	IP65
	Shock	MIL-STD-810G Method 516.6 Procedure I
	Vibration	MIL-STD-810G Method 514.6 Procedure I
	Drop	MIL-STD-810G Method 516.6, 4 ft to concrete*
	Certifications	CE, FCC
Power Management	Power Input	12-19V DC
	Battery	7.4V, typ. 5140 mAh Li-Polymer Battery (2S1P) 7.4V, typ. 10280 mAh Li-Polymer Battery (2S2P,Optional)
	Battery Operating Time	Std. Battery: 8 hours** High Capacity Battery: 16 hours**
	Adapter	100-240V, 50-60Hz, 19V DC



SCIGATE AUTOMATION (S) PTE LTD

No.1 Bukit Batok Street 22 #01-01 Singapore 659592
 Tel: (65) 6561 0488 Fax: (65) 6562 0588
 Email: sales@scigate.com.sg Web: www.scigate.com.sg

Business Hours: Monday - Friday 8.30am - 6.15pm

Dimensions :

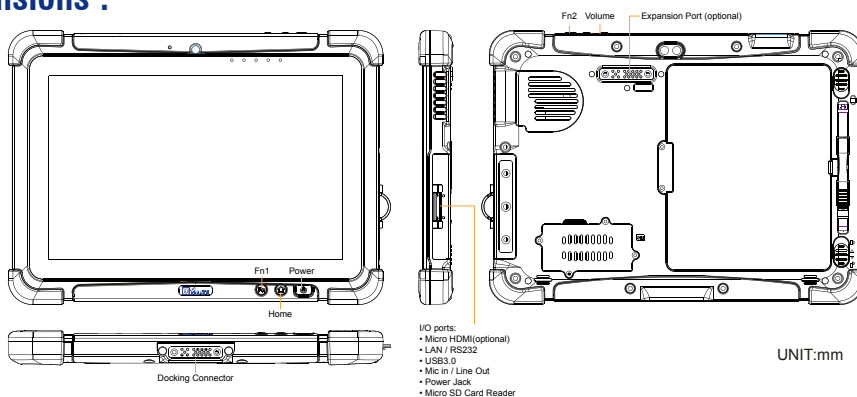

- * Note: The drop test with high-capacity battery must come with hand strap.
- ** Note: Measured at dimming LCD brightness. Varies depending on the usage conditions, or when an external device is attached.
- *** Note: this is a simplified drawing and some components are not marked in detail.
Please contact our sales representative if you need further product information.
- **** Note: All Specifications are subject to change without prior notice.

Accessories:

1. 19V 65W Power Adapter x 1
2. Power Cord x 1
3. Standard Battery x 1
4. M101 Quick Start Guide x 1
5. Manual & Driver CD x 1
6. Capacitive Stylus x 1

Order Information:

M101H Basic