

8" Vehicle Mount Computer

M800BW-M12

Product Features:

- Intel Braswell platform (N3160 1.6 GHz CPU, up to 2.24 GHz)
- Multi-Touch Projective Capacitive, with optical bonding
- Fan-Less & Robust Design
- Default with 4GB RAM/ 64GB SSD / GPS, WLAN, Bluetooth (built-in antenna)
- One M12 male connector external cable with D-SUB 15pin male connector (for use with CPM BOX)
- Optional:
 - LTE Module
 - 1D/ 2D Barcode Reader, Fingerprint Scanner, RFID Reader
 - VESA Mount Plate
 - Vehicle Cradle



Product Specifications:

System Specification	Processor	Intel® Celeron Processor N3160 1.6 GHz CPU, up to 2.24 GHz (Optional for Intel® Pentium® Processor N3710 1.6 GHz CPU, up to 2.56 GHz)
	System Memory	4GB SODIMM DDR3L-1600 (up to 8 GB)
	Storage	1 x 64GB M.2 MLC SSD (up to 512 GB)
	Operating System	Windows 10 IoT Enterprise
Display Specification	Size / Technology	8.0-inch
	Resolution	1280 x 800
	Brightness	550 nits (With Optical Bonding)
	Touch	Multi-touch Projected Capacitive with Glove / Rain / Normal Modes (Support Active Stylus)
	Contrast Ratio	800:1
Wireless Communication	Viewing Angle	85/85/85/85
	WLAN+Bluetooth	Intel® 802.11 a/b/g/n/ac + Bluetooth 4.0 Dual Mode Combo module
	GPS	u-Blox NEO-M8N (Optional for Glonass)
System I/O Buttons Indicators Sensors Security	Audio	2 x Built-in Digital Mic, 1 x Speaker
	Default I/O	2 x USB 3.0, 1 x Micro HDMI
	Service window	For WWAN Module
	Buttons	Micro SD, Micro SIM: Located in battery compartment
	Sensors	1 x Power, 2 x Programmable Function Keys
	LED Indicators	4 x LED indicators (Power, Battery status, SSD status, RF status)
	Sensors	Light sensor / G sensor / Gyro / E-compass
Camera	Front	2MP
	Rear	8MP (Autofocus with LED flash)
Mechanical and Environment	Dimension (W x L x H)	228.8 x 165.8 x 34 mm
	Housing	Plastic housing with fanless design
	Weight	1.1 Kg
	Operating Temperature	-20°C to 60°C ac mode, -10°C to 50°C battery mode
	Storage Temperature	-30°C to 60°C
	Humidity	10% to 95% RH, non-condensing
	IP Proof	IP65
	Vibration	MIL-STD-810G Method 514.6 Procedure I
Power Management	Certifications	CE, FCC
	Power Input	12 or 19V DC input
	Battery	7.6V typ. 5200mAh Li-ion Battery (2S2P)
Optional module	Battery Operating Time	7 Hours*
	WWAN	LTE: B1/B2/B3/B4/B5/B7/B8/B13/B17/B20 WCDMA/HSDPA/HSUPA/HSPA+: 850 MHz/900 MHz/1700 MHz (AWS)/1900 MHz/2100 MHz GPRS/EDGE
	Data Capture	Fingerprint Scanner, RFID Reader, 1D/ 2D Barcode Reader

* Note: Measured at dimming LCD brightness, RF not connected. Varies depending on the usage conditions, or when an external device is attached.

Dimensions :

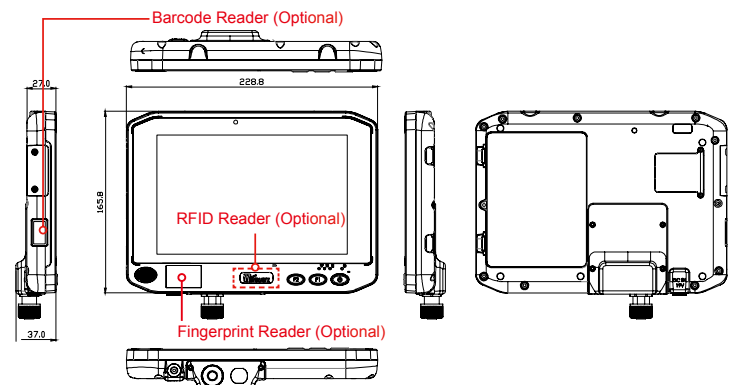
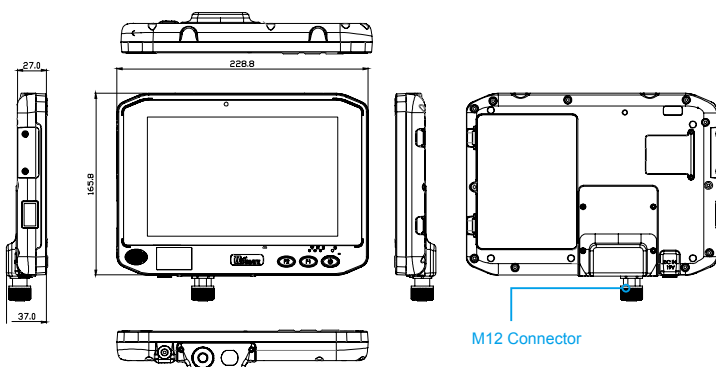

Default configuration

Optional configuration



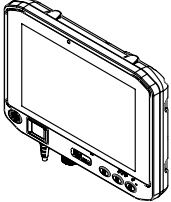

Package Contents

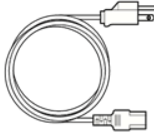
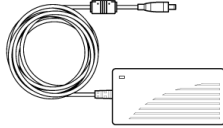
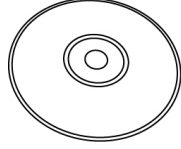
Before using this 8" Vehicle Mount Computer, please make sure that all the items listed below are present in your package:

				
Computer M800BW-M12	Standard Battery	Power Cord	Power adapter	Driver CD

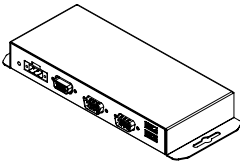
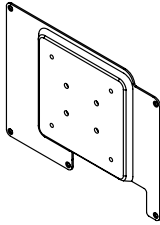
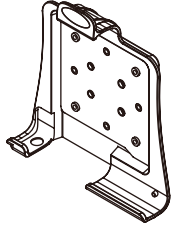
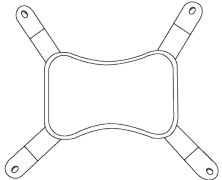
Optional Accessories

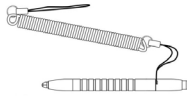
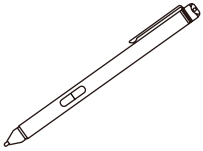
			
Expansion Box for M800BW-M12 with M12 to D-Sub Male Cable (for connecting M800BW-M12)	VESA Plate	Vehicle Cradle	Hand Strap
98DT00A00008	98K000A0008H	98D000A0000L	98K000A0008C
			
Mounting kit 1 – No Drill Solution	Mounting kit 2 – Drill Solution	Stylus	Active Stylus
98K000A0008P	98K000A0008O	98K000A0008G	98K000A0008F

Optional Mounting Solution

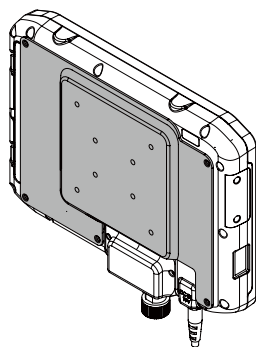

VESA Plate

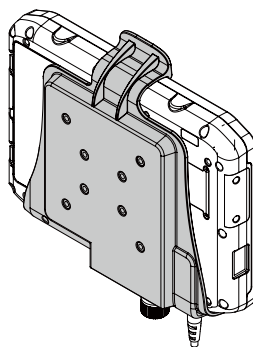

Vehicle Cradle

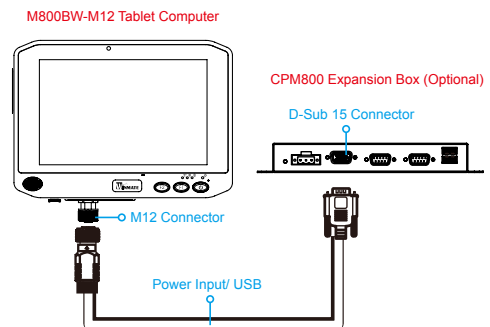

CPM 800 Installation Diagram

Ordering Information

M800BW-M12	Standard
M800BW-M12BM	with 1D/2D Barcode Reader
M800BW-M12FP	with Fingerprint Scanner
M800BW-M12BF	with 1D/2D Barcode Reader and Fingerprint Scanner
M800BW-M12HF	with RFID Reader



SCIGATE AUTOMATION (S) PTE LTD
 No.1 Bukit Batok Street 22 #01-01 Singapore 659592
 Tel: (65) 6561 0488 Fax: (65) 6562 0588
 Email: sales@scigate.com.sg Web: www.scigate.com.sg
 Business Hours: Monday - Friday 8.30am - 6.15pm