

GS65 Display



10.4"

Specifications



Model Name	R10L100-GST2
Resolutions	10.4"
Active Display Area(mm)	1024x768
Brightness(cd/m ²)	350 cd/m ² (typ.)
Contrast Ratio	0.21525 (V)
Viewing Angle	1200 : 1 (typ.)
Active Display Area(mm)	210.4(H) x 157.8 (V)
Pixel Pitch(mm)	0.2055 (H) x 0.2055 (V)
Touch	Projected Capacitive Touch
Power Source	9-36V DC with External AC to DC Adapter (100~240V AC)
Power Consumption	15 W typical, normal operation
Operating Temperature	-15 °C to 55 °C
Operating Humidity	10% to 95% (non-condensing)
IP Rating	Full IP65
Input Ports	1 x VGA 1 x Touch(USB)
USB Port (Touch)	1 x USB 2.0
Mounting	VESA Mount (100x100mm)
Dimensions (W x H x D)	296.2 x 226.7 x 45.5 (mm)
Accessory	Vesa Mounting Arm / Table Stand Mount

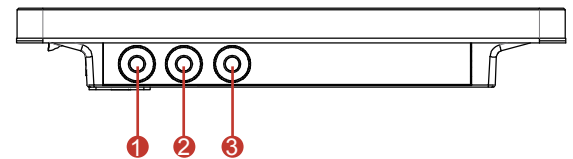

1. 9-36V DC (M12 type)
2. VGA (M12 type)
3. USB For Touch(M12 type),
only with Touch
4. OSD Power

Mechanical Drawing

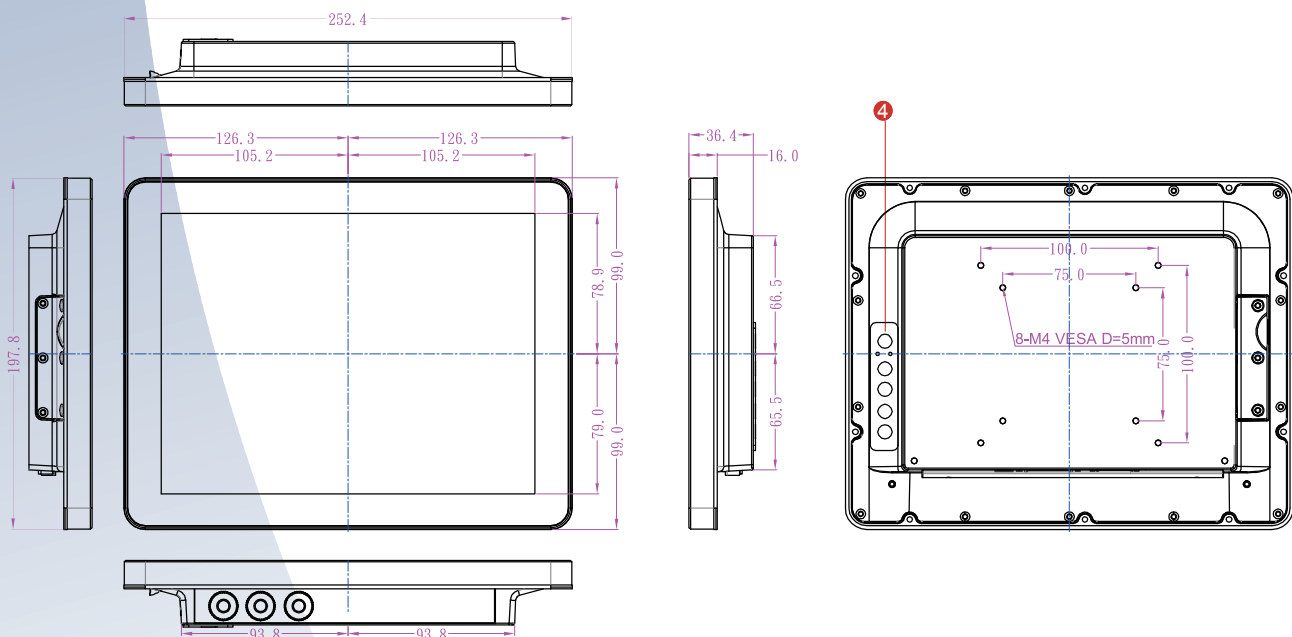

UNIT:mm

GS65 Display

M12 Power Cable

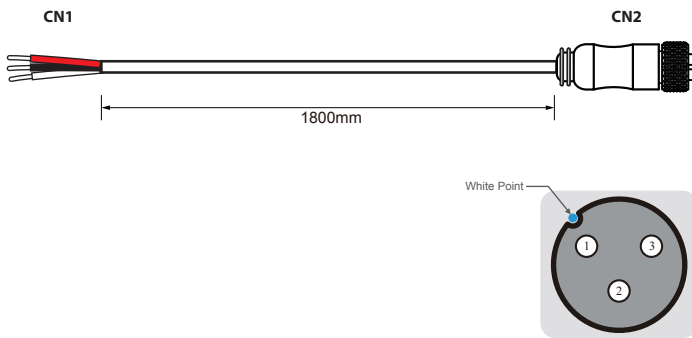

Pin No.	Symbols	Color		Pin No.	Symbols	Color
CN1-1	VCC+	Red	↔	CN2-1	VCC+	Red
CN1-2	GND	Black	↔	CN2-2	GND	Black
CN1-3	VCC-	White	↔	CN2-3	VCC-	White

VGA Cable

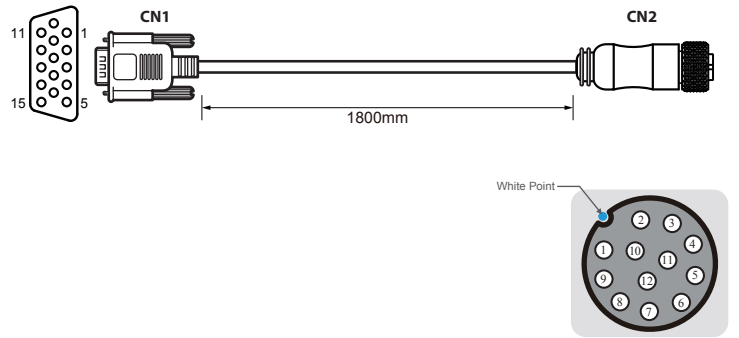

Pin No.	Symbols	Color		Pin No.	Symbols	Color
CN1-1	R	Red	↔	CN2-1	R	Red
CN1-6	R-GND	Black	↔	CN2-2	R-GND	Black
CN1-5	G	Green	↔	CN2-3	G	Green
CN1-7	G-GND	Black	↔	CN2-4	G-GND	Black
CN1-3	B	Blue	↔	CN2-5	B	Blue
CN1-8	B-GND	Black	↔	CN2-6	B-GND	Black
CN1-12	SDA	Yellow	↔	CN2-7	SDA	Yellow
CN1-13	HS	Orange	↔	CN2-8	HS	Orange
CN1-14	VS	White	↔	CN2-9	VS	White
CN1-15	SCL	Brown	↔	CN2-10	SCL	Brown

USB for Touch Cable

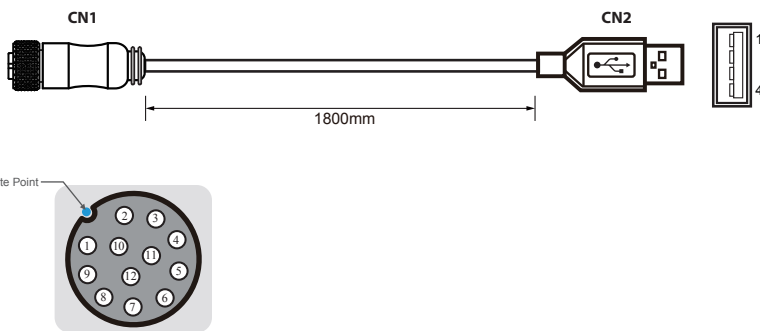

Pin No.	Symbols	Color		Pin No.	Symbols	Color
CN1-2	VCC	Red	↔	CN2-1	VCC	Red
CN1-3	D-	White	↔	CN2-2	D-	White
CN1-4	D+	Green	↔	CN2-3	D+	Green
CN1-5	GND	Black	↔	CN2-4	GND	Black
CN1-9	GND	Black	↔	CN2 Shell		Black



SCIGATE AUTOMATION (S) PTE LTD

No.1 Bukit Batok Street 22 #01-01 Singapore 659592
 Tel: (65) 6561 0488 Fax: (65) 6562 0588
 Email: sales@scigate.com.sg Web: www.scigate.com.sg
 Business Hours: Monday - Friday 8.30am - 6.15pm