

Rugged Display



Model:R10L100-VMP3

Product Features:

- High Quality 10.4" panel, 640 x 480 resolution, 450 nits
- 5 Wire resistive touch screen / IR Touch
- -25 ~ +55°C Wide Range Operating Temperature
- Anti-Corrosion housing with Fanless Design
- IP65 Dust & Waterproof Protection (Except I/O ports)
- 9V ~ 36V DC Isolation Wide Range Power Input
- Compliance With EN50155

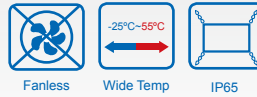

I / O View:

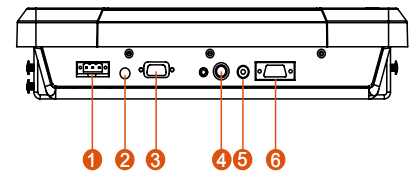

BOTTOM VIEW

1. 9~36V DC Terminal Block (Default)
2. DC Lockable Input (Optional)
3. RS-232 for Touch (Optional)
4. S-Video (Optional)
5. Composite (Optional)
6. VGA

Product Specifications:

	Model Name	R10L100-VMA2
	Size	10.4"
Display	Resolution (pixels)	640 x 480
	Number of Colors	16.2M (8bits/color)
	Brightness (cd/m2)	450nits (typ.)
	Contrast Ratio	700:1 (typ.)
	Viewing Angle	-80~80 (H) ; -60~80 (V)
	Active Area	211.2 (H) x 158.4 (V)
	Touch (optional)	5 wire resistive / IR Touch
Input / Output	1 x 9~36V DC Terminal Block (Default)	
	1 x DC Lockable Input (Optional)	
	1 x RS-232 for Touch (Optional)	
	1 x S-Video (Optional)	
	1 x Composite (Optional)	
	1 x VGA	
Environment	Operating Temperature	-25 ~ 55°C
	Storage Temperature	-30 ~ 70°C
	Humidity	10 ~ 95% non-condensing
	Shock	Compliance with MIL810F/EN50155
	Vibration	Compliance with MIL810F/EN50155
	EMC	CE, FCC ClassB
	Reliability	Need to apply 9~36V DC isolation power design
Mechanical	Dimension(W x H x D)	315.9 x 250.9 x 67mm
Packing List	R5W AD Board User's Manual Touch's Driver CD	
Product Optional Items	Mounting Bracket and Kits	One robust bracket with locking handle (can adjust from -5deg. to 90deg.)
	Video Input	Composite Video, S-Video for optional
	Anti-reflective Glass	3 mm (Replace touch)

Front OSD Control Function:

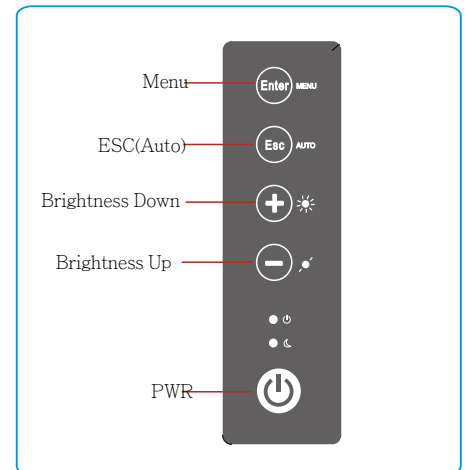

Drawing:

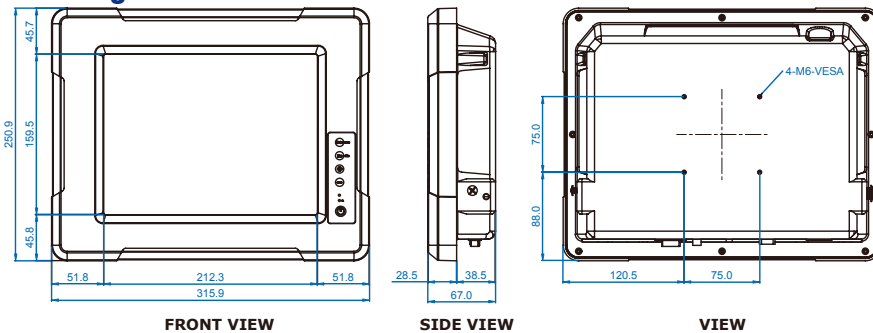

FRONT VIEW

SIDE VIEW

VIEW

Drawing w / Mounting Bracket

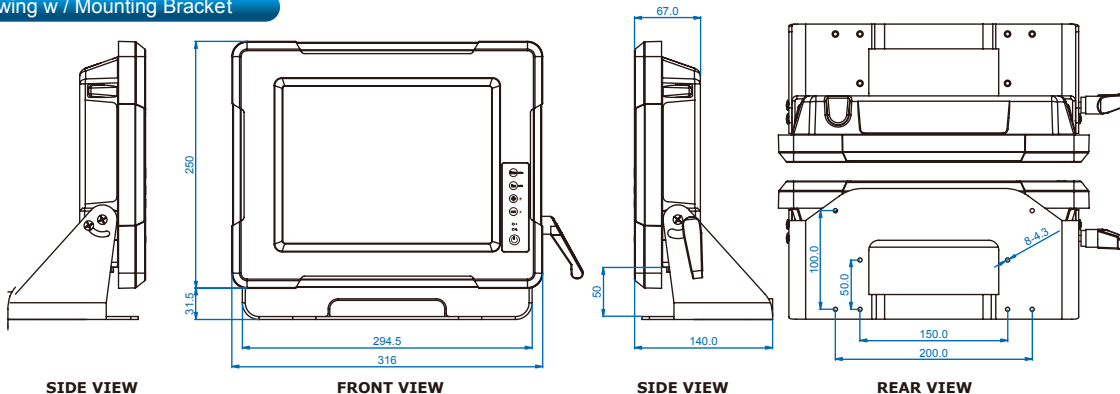

SIDE VIEW

FRONT VIEW

SIDE VIEW

REAR VIEW



SCIGATE AUTOMATION (S) PTE LTD
 No.1 Bukit Batok Street 22 #01-01 Singapore 659592
 Tel: (65) 6561 0488 Fax: (65) 6562 0588
 Email: sales@scigate.com.sg Web: www.scigate.com.sg
 Business Hours: Monday - Friday 8.30am - 6.15pm

Rev.	Reasons	Revised Date
1.3	Spec change	Dec.16.11
1.4	Spec change	Jun.18.13
1.5	Spec change	Nov.26.13

