

Rugged Display



Model:R10L100-VMT2

Product Features:

- High Quality 10.4" panel, 1024 x 768 resolution, 350 nits
- 5 Wire resistive touch screen / IR Touch
- -25 ~ +55°C Wide Range Operating Temperature
- Anti-Corrosion housing with Fanless Design
- IP65 Dust & Waterproof Protection (Except I/O ports)
- 9V ~ 36V DC Isolation Wide Range Power Input
- Compliance With EN50155

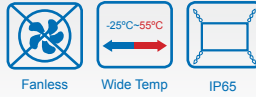

Product Specifications:

Display	Model Name	R10L100-VMT2
	Size	10.4"
	Resolution (pixels)	1024 x 768
	Number of Colors	16.2M (6bits+FRC)
	Brightness (cd/m2)	350
	Contrast Ratio	1200:1
	Viewing Angle	-88~88 (H) ; -88~88 (V)
	Active Area	210.4 (H) x 157.8 (V)
Input /Output	Touch (optional)	5 wire resistive / IR Touch
	1 x 9~36V DC Terminal Block (Default)	
	1 x DC Lockable Input (Optional)	
	1 x RS-232 or USB for Touch (Optional)	
	1 x S-Video (Optional)	
	1 x Composite (Optional) 1 x VGA	
Environment	Operating Temperature	-25 ~ 55°C
	Storage Temperature	-30 ~ 70°C
	Humidity	10 ~ 95% non-condensing
	Shock	Compliance with MIL810F/EN50155
	Vibration	Compliance with MIL810F/EN50155
	EMC	CE, FCC ClassB
Mechanical	Safety	Compliance with EN50155, MIL-STD 810F
	Dimension(W x H x D)	315.9 x 250.9 x 67mm
Packing List	R5W AD Board User's Manual Touch's Driver CD	
Product Optional Items	Mounting Bracket and Kits	One robust bracket with locking handle (can adjust from -5deg. to 90deg.)
	Video Input	Composite Video, S-Video for optional
	Anti-reflective Glass	3 mm (Replace touch)

I / O View:

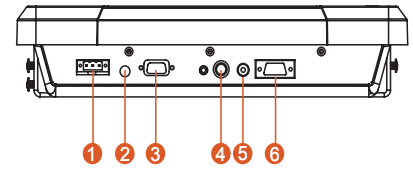

BOTTOM VIEW

1. 9~36V DC Terminal Block (Default)
2. DC Lockable Input (Optional)
3. RS-232 or USB for Touch (Optional)
4. S-Video (Optional)
5. Composite (Optional)
6. VGA

Front OSD Control Function:

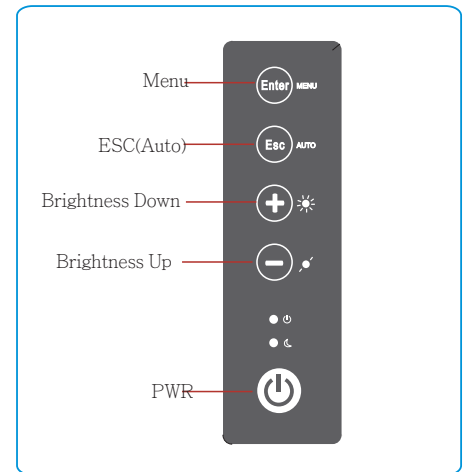

Drawing:

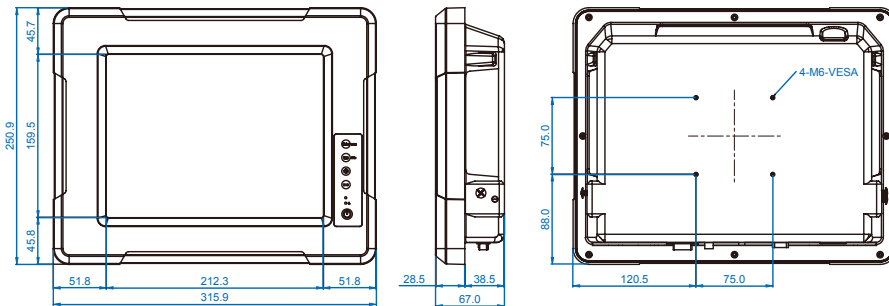

FRONT VIEW

SIDE VIEW

VIEW

Drawing w / Mounting Bracket

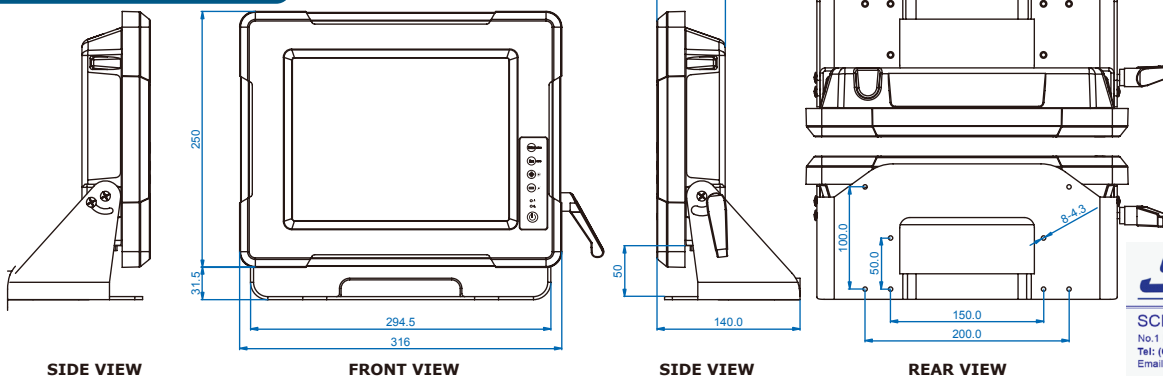

SIDE VIEW

FRONT VIEW

SIDE VIEW

REAR VIEW



SCIGATE AUTOMATION (S) PTE LTD
 No.1 Bukit Batok Street 22 #01-01 Singapore 659592
 Tel: (65) 6561 0488 Fax: (65) 6562 0588
 Email: sales@scigate.com.sg Web: www.scigate.com.sg
 Business Hours: Monday - Friday 8.30am - 6.15pm

