

HMI Panel PC

Model:R15FA3S-IPC3HM

Product Features:

- 15" 1024 x 768 TFT LCD with resistive touch screen
- Freescale Cortex A9 i.MX6 Dual Core 1GHz (Optional Quad Core)
- Onboard LPDDR3 1 GB (Optional for 2GB)
- Onboard 16GB eMMC Flash
- 1 x USB 2.0; 1 x RS-232/422/485; 1 x Micro SD Slot, 1 x Mini USB, 1 x Micro HDMI
- PoE function (Optional)
- Fanless and Ultra-low power consumption



Front IP65



Fanless



PoE



IP65/ NEMA4

Product Specifications:

System Specification	Processor	Freescale Cortex A9 i.MX6 Dual Core 1GHz (Optional Quad Core)
	Memory	1GB LPDDR3 (Optional for 2 GB)
	Storage	Onboard 16GB eMMC (Default) Micro SD card
	Operating System	Android 4.4 (Default) Linux 4.1.15 , QT 5.5 (Optional) Ubuntu 16.04 (Optional)
Display Specification	Size/Type	15" TFT(LED Backlight)
	Resolution (pixels)	1024 x 768
	Brightness (cd/m2)	250 cd/m ²
	Touch interface	Resistive Touch
Input / Output	Serial Interface	1 x RS-232/422/485
	USB Port	1 x USB 2.0, 1 x USB OTG
	Ethernet Port	1 x RJ45, 10/100/1000 LAN (Supports PoE function)
	SD Card	1 x Micro SD Card Slot
	CANBUS	1 x CANBUS
	Power Input	1 x Terminal Block 2 Pin (Phoenix Type)
	Console	1 x Mini USB
Power	Power Input	12V DC Support PoE (Optional) Power Device (PD): follows IEEE 802.3at (25 W)
	Power consumption	15W
Environment	Operating Temperature	0 deg.C to 50 deg.C
	Storage Temperature	-10 deg.C to 60 deg.C
	Humidity	10% to 90% (non-condensing)

Mechanical Design:

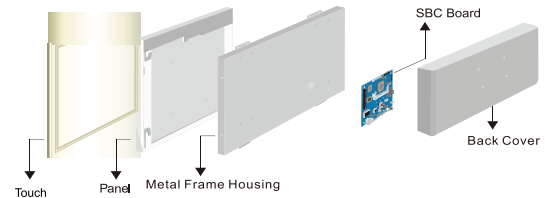

I / O View:

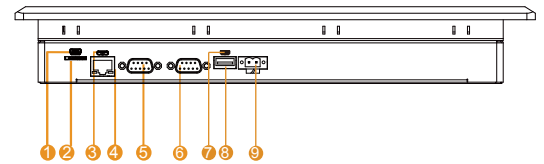

1. Console Port (Mini USB)
2. Micro SD
3. LAN/Optional PoE
4. USB OTG
5. RS-232/422/485
6. CANBUS
7. Micro HDMI
8. 1 x USB 2.0
9. 12V DC (2pin Phoenix type)

Dimensions:

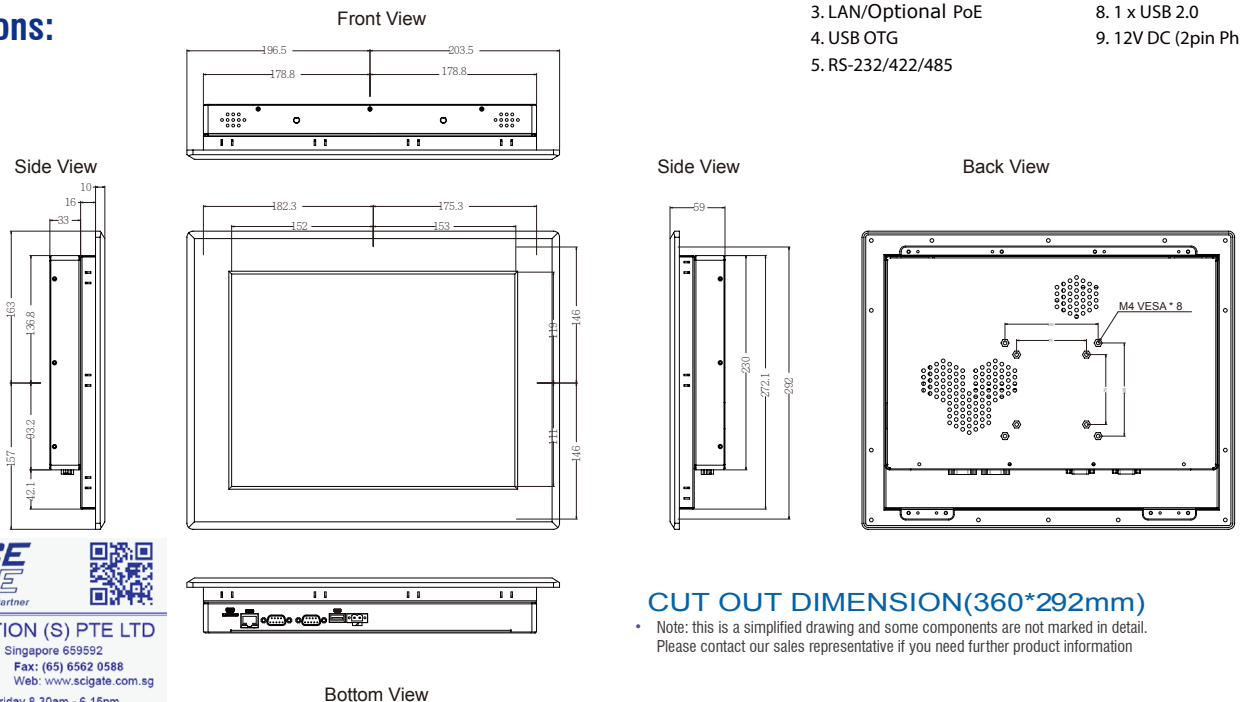

CUT OUT DIMENSION(360*292mm)

- Note: this is a simplified drawing and some components are not marked in detail. Please contact our sales representative if you need further product information



SCIGATE AUTOMATION (S) PTE LTD
 No.1 Bukit Batok Street 22 #01-01 Singapore 659592
 Tel: (65) 6561 0488 Fax: (65) 6562 0588
 Email: sales@scigate.com.sg Web: www.scigate.com.sg
 Business Hours: Monday - Friday 8.30am - 6.15pm

