

# 15" GS65 Panel PC

# R15IB3S-GSC3(HB)

## Features

- 15" 1024 x 768 Resolution with Projected Capacitive Multi-Touch (P-CAP)
- Intel® Celeron® Bay Trail-M N2930 1.83 GHz
- Fanless cooling system and ultra-low power consumption
- Edge-to-edge design
- Full IP65 design with Special M12 Waterproof connectors
- 1 x LAN, 1 x RS232, 1 x USB 2.0

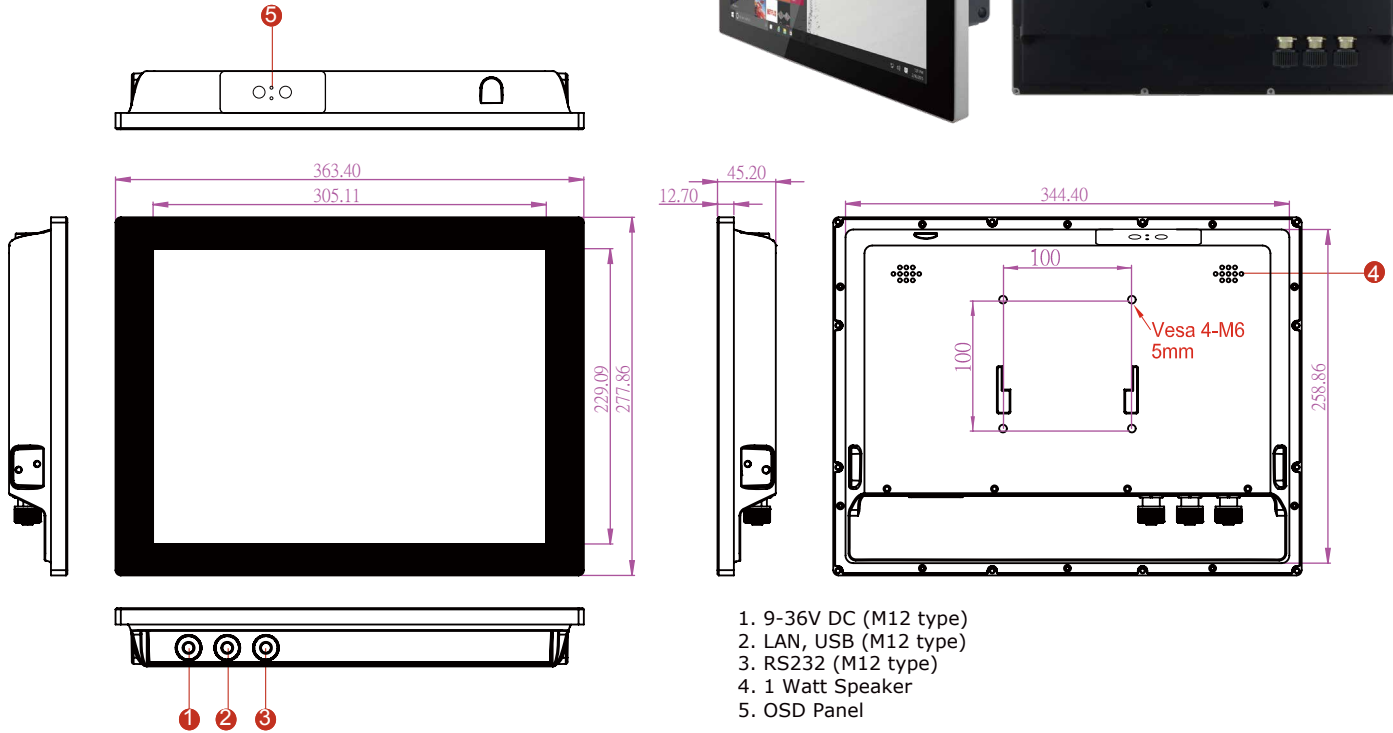

1. 9-36V DC (M12 type)
2. LAN, USB (M12 type)
3. RS232 (M12 type)
4. 1 Watt Speaker
5. OSD Panel

## Specifications

### System

- Processor : Intel® Celeron® Bay Trail-M N2930 1.83GHz
- Memory : 2GB DDR3L-1600 SODIMM (max. 8GB)
- Storage : mSATA SSD 64GB
- System Chipset : Intel® ATOM SoC Integrated

### Input / Output

- COM Port : 1 x RS232 (M12 type)(Optional 422/485)
- USB Port : 1 x USB 2.0 (M12 type)
- Ethernet : 1 x 10/100/1000 LAN (M12 type)
- Speaker : 1 x 1 Watt Speaker

### Operating System

- Operating System : Windows 10 IoT Enterprise  
Windows Embedded 8.1 Industry Pro  
Windows Embedded Standard 7

### Security Support

- Trusted Platform Module (TPM 1.2)

### Power Considerations

- Power Input : 9-36V DC (M12 type)
- Power consumption : 25W

### Display

- Size/Type : 15" TFT
- Resolution : 1024 x 768
- Brightness : 250 cd/m (typ.) Optional for High Brightness 1000 cd/m (typ.)
- Contrast Ratio : 700:1 (typ.)
- Viewing Angle : -80~80(H); -70~70(V)
- Max Colors : 16.2M colors (8bits)
- Touch : Projective-Capacitive Touch

### Software Support

- Watchdog SDK

### Mechanical Specification

- Cooling System : Fanless design
- Mounting : VESA Mount (100x100mm), Panel Mount
- Dimensions(W x H x D): 363.40 x 277.86 x 44.50 mm

### Environment Considerations

- Operating Temperature : -15 deg. C to 55 deg. C
- Operating Humidity : 10% to 95% (non-condensing)
- IP Rating : Full IP65
- Shock Operating : 30g for 18ms, 300m/s<sup>2</sup>
- Vibration Operating : 1.60/1.96/2.18 g rms for XYZ/ 5-500Hz

### Certifications & Standards

- Compliant with MIL-STD-810F/G for vibration / shock, CE, FCC



# 15" GS65 Panel PC

# R15IB3S-GSC3(HB)

## Pin Assignment of cables

### RS-232 to M12 Cable

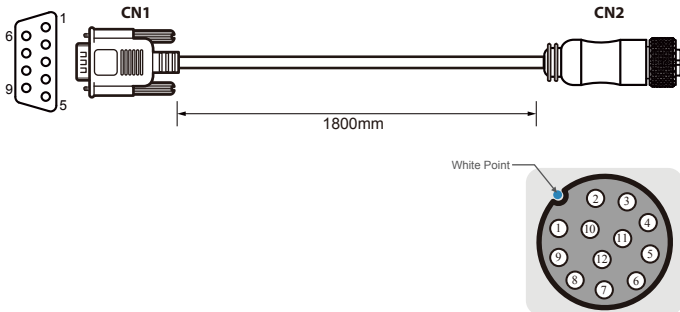

Pin No.	Symbols	Color		Pin No.	Symbols	Color
CN1-1	DCD	Green	↔	CN2-1	DCD	Green
CN1-6	DSR	Brown	↔	CN2-2	DSR	Brown
CN1-2	RXD	Red	↔	CN2-3	RXD	Red
CN1-7	RTS	Orange	↔	CN2-4	RTS	Orange
CN1-3	TXD	Blue	↔	CN2-5	TXD	Blue
CN1-8	CTS	White	↔	CN2-6	CTS	White
CN1-4	DTR	Purple	↔	CN2-7	DTR	Purple
CN1-9	RI	Yellow	↔	CN2-8	RI	Yellow
CN1-5	GND	Black	↔	CN2-9	GND	Black

### DC Power to M12 Cable

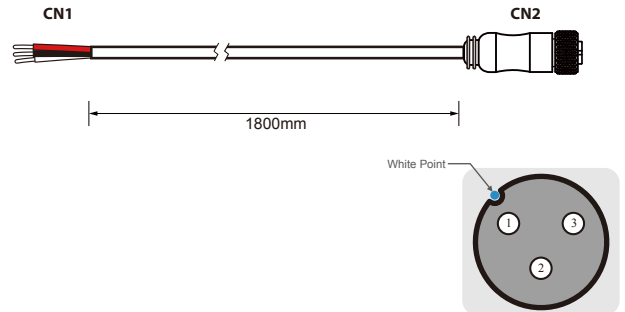

Pin No.	Symbols	Color		Pin No.	Symbols	Color
CN1-1	VCC+	Red	↔	CN2-1	VCC+	Red
CN1-2	GND	Black	↔	CN2-2	GND	Black
CN1-3	VCC-	White	↔	CN2-3	VCC-	White

### USB 2.0 & GIGA LAN to M12 Cable

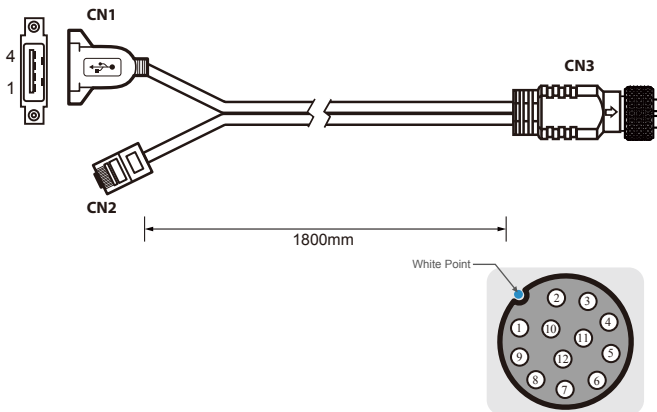

Pin No.	Symbols	Color		Pin No.	Symbols	Color
CN3-1	VCC	RED	↔	CN1-1	VCC	RED
CN3-2	D-	WHITE	↔	CN1-2	D-	WHITE
CN3-3	D+	GREEN	↔	CN1-3	D+	GREEN
CN3-4	GND	BLACK	↔	CN1-4	GND	BLACK
CN3-5	White/Orange		↔	CN2-1	White/Orange	
CN3-6	Orange		↔	CN2-2	Orange	
CN3-7	White/Green		↔	CN2-3	White/Green	
CN3-8	Blue		↔	CN2-4	Blue	
CN3-9	White/Blue		↔	CN2-5	White/Blue	
CN3-10	Green		↔	CN2-6	Green	
CN3-11	White/Brown		↔	CN2-7	White/Brown	
CN3-12	Brown		↔	CN2-8	Brown	



**SCIGATE AUTOMATION (S) PTE LTD**  
 No.1 Bukit Batok Street 22 #01-01 Singapore 659592  
 Tel: (65) 6561 0488 Fax: (65) 6562 0588  
 Email: sales@scigate.com.sg Web: www.scigate.com.sg  
 Business Hours: Monday - Friday 8.30am - 6.15pm