

## Chassis Monitor

15"

### Specifications



Model Name	R15L100-SDA3
Viewable Size Image	15"
Active Display Area(mm)	304.1(H) x 228.1(V)
Pixel Pitch(mm)	0.297(H)x0.297(V)
Number of Pixels	1024 x 768
Contrast Ratio	700:1(typ.)
Display Color	16.7M (8bits/color)
Brightness(cd/m <sup>2</sup> )	550
Viewing Angle(CR>= 10)	-80~80(H);-70~70(V)
Synchronization Range	
Horizontal/Vertical	31.5~80.0KHz/60~75Hz
Recommended Resolution	1024 x 788 @60Hz
Signal Connector	1 x HDMI 1.3 1 x VGA 2 x CVBS (BNC) 1 x 3G-SDI in 1 x 3G-SDI out (loop out)
Power Source	12V DC in, with External AC to DC Adapter (100~240V AC)
Power Consumption	20W typical, normal operation
Touch Screen	Multi-touch Projected Capacitive

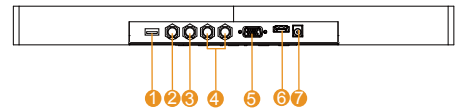

1. USB for Touch
2. 3G-SDI output
3. 3G-SDI input
4. 2 x CVBS
5. VGA
6. HDMI 1.3
7. Power input

### Mechanical Drawing

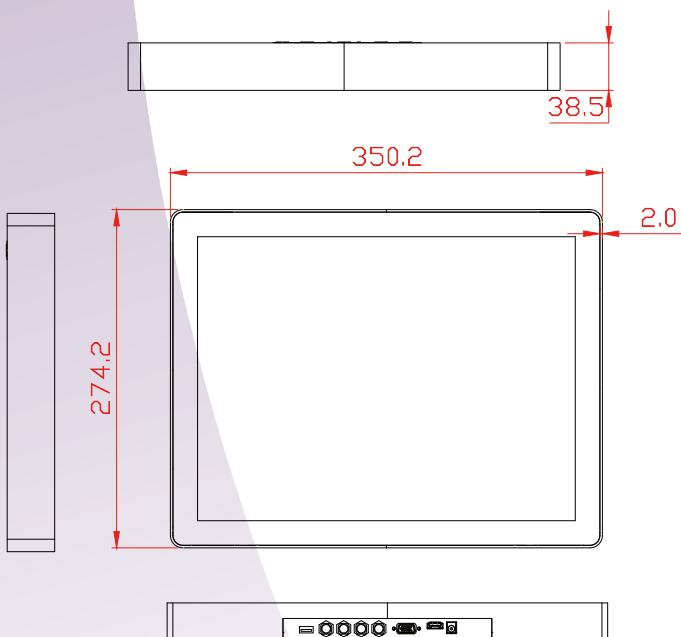

**SCIENCE GATE**  
Your Automation Partner

**SCIGATE AUTOMATION (S) PTE LTD**  
No.1 Bukit Batok Street 22 #01-01 Singapore 659592  
Tel: (65) 6561 0488 Fax: (65) 6562 0588  
Email: sales@scigate.com.sg Web: www.scigate.com.sg  
Business Hours: Monday - Friday 8.30am - 6.15pm

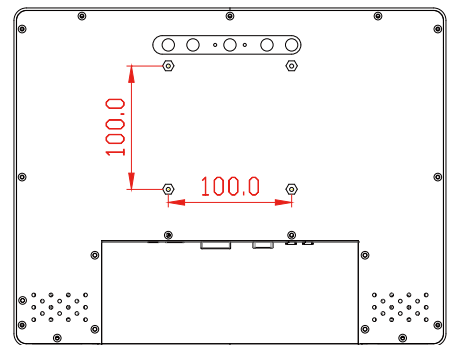

UNIT:mm

\* Note: this is a simplified drawing and some components are not marked in detail. Please contact our sales representative if you need further product information.