

HMI Panel PC

Model:W10FA3S-OFH1HM

Product Features:

- 10.1" 1024 x 600 TFT LCD with resistive touch screen
- Freescale Cortex A9 i.MX6 Dual Core 1GHz (Optional Quad Core)
- Onboard LPDDR3 1 GB (Optional for 2GB)
- Onboard 16GB eMMC Flash
- 1 x USB 2.0; 1 x RS-232/422/485; 1 x Micro SD Slot, 1 x Mini USB, 1 x Micro HDMI
- PoE function (Optional)
- Fanless and Ultra-low power consumption



Open Frame

Product Specifications:

System Specification	Processor	Freescale Cortex A9 i.MX6 Dual Core 1GHz (Optional Quad Core)
	Memory	1GB LPDDR3 (Optional for 2 GB)
	Storage	Onboard 16GB eMMC (Default) Micro SD card
	Operating System	Android 4.4 (Default) Linux 4.1.15 , QT 5.5 (Optional) Ubuntu 16.04 (Optional)
Display Specification	Size/Type	10.1" TFT(LED Backlight)
	Resolution (pixels)	1024 x 600
	Brightness (cd/m ²)	200 cd/m ²
	Touch interface	5 Wire Resistive Touch
Input / Output	Serial Interface	1 x RS-232/422/485
	USB Port	1 x USB 2.0, 1 x USB OTG
	Ethernet Port	1 x RJ45, 10/100/1000 LAN (Supports PoE function)
	SD Card	1 x Micro SD Card Slot
	CANBUS	1 x CANBUS
	Power Input	1 x Terminal Block 2 Pin (Phoenix Type)
	Console	1 x Mini USB
	Micro HDMI	1 x Micro HDMI
Power	Power Input	12V DC Support PoE (Optional) Power Device (PD): follows IEEE 802.3at (25 W)
	Power consumption	10W
Environment	Operating Temperature	0 deg.C to 50 deg.C
	Storage Temperature	-10 deg.C to 60 deg.C
	Humidity	10% to 90% (non-condensing)

Mechanical Design:

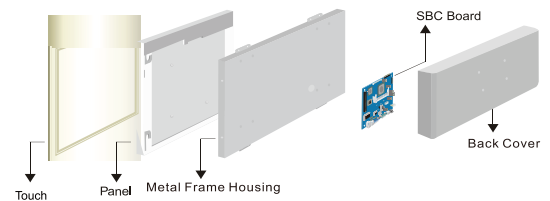

I / O View:

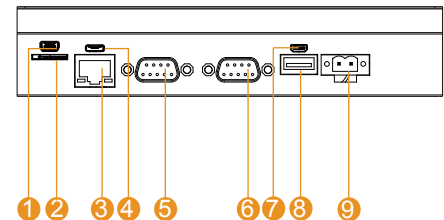

- | | |
|----------------------------|-------------------------------|
| 1. Console Port (Mini USB) | 6. CANBUS |
| 2. Micro SD | 7. Micro HDMI |
| 3. LAN/Optional PoE | 8. 1 x USB 2.0 |
| 4. USB OTG | 9. 12V DC (2pin Phoenix type) |
| 5. RS-232/422/485 | |

Dimensions:

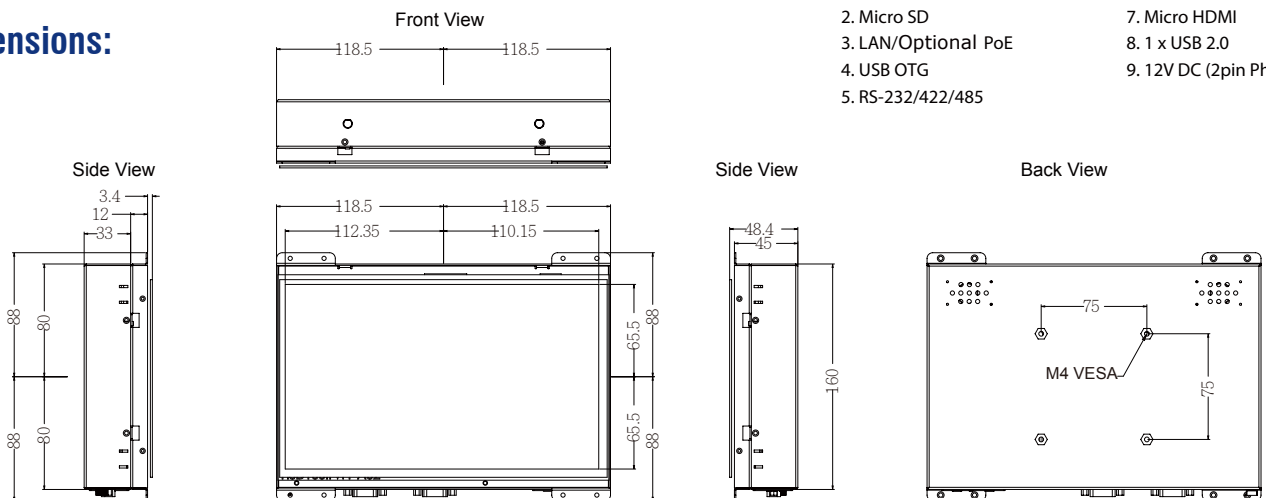

SCIGATE AUTOMATION (S) PTE LTD
 No.1 Bukit Batok Street 22 #01-01 Singapore 659592
 Tel: (65) 6561 0488 Fax: (65) 6562 0588
 Email: sales@scigate.com.sg Web: www.scigate.com.sg
 Business Hours: Monday - Friday 8.30am - 6.15pm

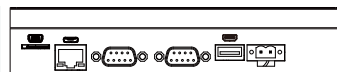

Bottom View

• Note: this is a simplified drawing and some components are not marked in detail. Please contact our sales representative if you need further product information

