

Chassis Monitor



SCIGATE AUTOMATION (S) PTE LTD

No.1 Bukit Batok Street 22 #01-01 Singapore 659592

Tel: (65) 6561 0488

Fax: (65) 6562 0588

Email: sales@scigate.com.sg

Web: www.scigate.com.sg

Business Hours: Monday - Friday 8.30am - 6.15pm

10.1"

Specifications



Model Name	W10L100-SDH2
Viewable Size Image	10.1"
Active Display Area(mm)	216.69(H) x 135.6(V)
Pixel Pitch(mm)	0.1695(H) x 0.1695(V)
Number of Pixels	1280 x 800
Contrast Ratio	800:1(typ.)
Display Color	16.7M (8bits/color)
Brightness(cd/m ²)	300
Viewing Angle(CR>=10)	-80~80(H);-70~70(V)
Synchronization Range	
Horizontal/Vertical	31.5~80.0KHz/60~75Hz
Recommended Resolution	1280 x 800 @60Hz
Signal Connector	1 x HDMI 1.3 1 x VGA 2 x CVBS (BNC) 1 x 3G-SDI in 1 x 3G-SDI out (loop out)
Power Source	12V DC in, with External AC to DC Adapter (100~240V AC)
Power Consumption	15W typical, normal operation
Touch Screen	Multi-touch Projected Capacitive

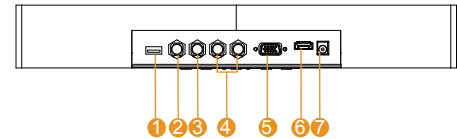

- 1. USB for Touch
- 2. 3G-SDI output
- 3. 3G-SDI input
- 4. 2 x CVBS
- 5. VGA
- 6. HDMI 1.3
- 7. Power input

Mechanical Drawing

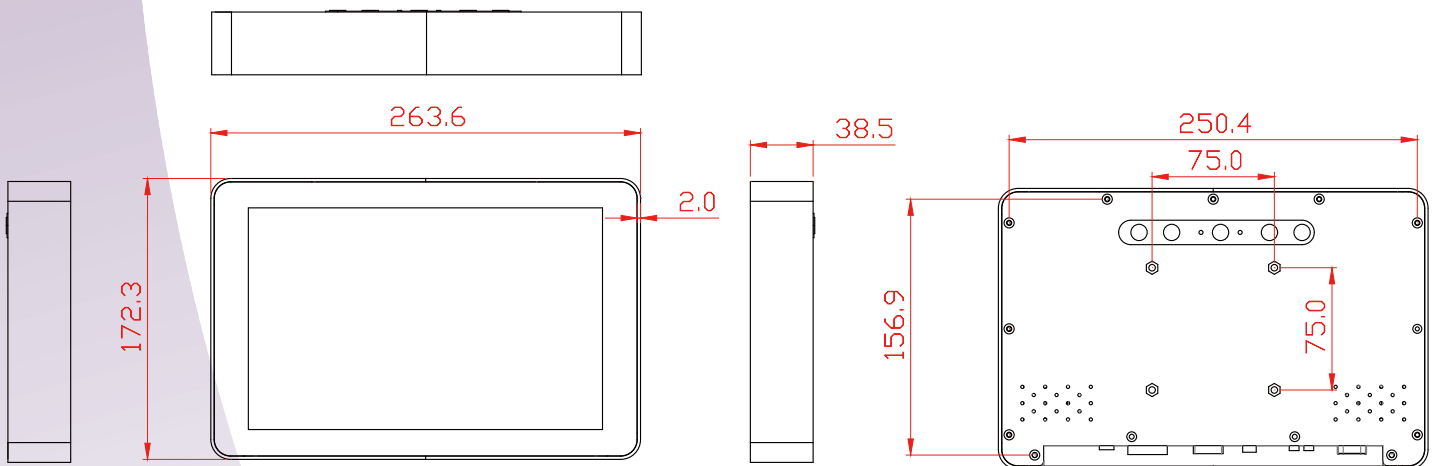

UNIT:mm

* Note: this is a simplified drawing and some components are not marked in detail. Please contact our sales representative if you need further product information.