

Application



The general purpose ultrasonic level transmitter provides continuous level measurement up to 49.2" (1.25m) with a selectable 0-5 VDC, 0-10 VDC or 976-2000 Hz frequency signal output, and is configured via our free WebCal software. Select the voltage output for interface with analog input cards. Select the frequency output for interface with discrete input cards. This non-contact liquid level sensor is ideally suited for corrosive, sticky or dirty liquids, and is widely selected for small day tank, skid, IBC, sump and process tank level applications.



Features

- ✓ Continuous non-contact level measurement up to 49.2" (1.25m)
- ✓ Selectable voltage or frequency (discrete) signal outputs
- ✓ Configuration is fast and easy via WebCal software and USB adapter
- ✓ Narrow 2" beam width and short 2" dead band optimized for small tanks
- ✓ PVDF transducer and 6P polycarbonate enclosure for corrosive liquids
- ✓ Automatic temperature compensation for accurate measurement

Success



The disinfection of fresh produce and associated processing equipment is essential to public health. Fruits and vegetables such as strawberries, head lettuce, tomatoes, oranges and artichokes are susceptible to bacterial and viral contamination. Each year, approximately 40K Americans succumb to Hepatitis A food poisoning. Adults who become ill miss an average of 27 work days. Eleven percent of them are hospitalized and 100 people die each year from acute liver failure. Good Manufacturing Practices and new FDA recommendations call for the disinfection of all fresh produce and processing equipment. To accomplish this, produce suppliers are deploying automated systems that generate, inventory and inject chlorine dioxide into their processes. These are typically small systems that use 55-gal-drum or mini-bulk tanks for chemical make up and storage. From inventory to data-logging, level is critical in these highly corrosive applications. EchoPod is the reliable, level measurement, switch and control solution for chlorine disinfection systems.

Compatible Products

DataLoop™
Level Indicator



DataView™
Level Controller



Commander™
Multi-Tank Level Controller



DataPoint™
Level Controller



Specifications

Range: 49.2" (1.25m)
Accuracy: 0.125" (3mm)
Resolution: 0.019" (0.5mm)
Dead band: 2" (5cm)
Beam width: 2" (5cm)
Configuration: WebCal® PC
 Windows® USB 2.0
Memory: Non-volatile
Supply voltage: 12-24 VDC
Consumption: 0.5W
Signal output: 0-5 V, 0-10 V, 976-2000 Hz
Frequency: Sink current, 15 mA nominal
Signal invert: 5-0 V, 10-0 V, 2000-976 Hz
Signal fail-safe: Full, empty or hold last
Process temp.: F: 20° to 140°
 C: -7° to 60°
Temp. comp.: Automatic
Ambient temp.: F: -31° to 140°
 C: -35° to 60°
Pressure: MWP = 30 PSI (2 bar)
Enclosure rating: Type 6P, encapsulated,
 corrosion resistant &
 submersible
Encl. material: Polycarbonate
Strain relief mat: Santoprene
Trans. material: PVDF
Cable jacket mat: Polyurethane
Cable type: 6-conductor, shielded
Cable length: 48" (1.2m)
Process mount: 1" NPT (1" G)
Mount gasket: Viton®
Classification: General purpose
Compliance: CE, RoHS
Approvals: cFMus

Dimensions

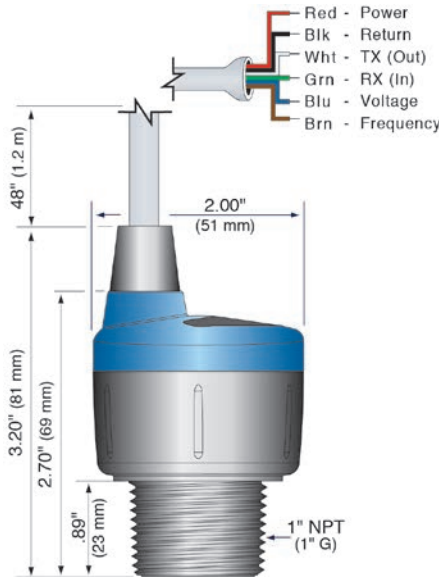

Configuration



The level sensor is configurable via our free WebCal PC software and Fob USB adapter. The sensors are offered with and without Fobs. Fobs are universal and can be used to configure any WebCal compatible product.

Download your free copy of WebCal in English or Chinese at www.flowline.com/webcal.php.

Fittings

For optimum performance, install the level sensor using the below recommended or direct equivalent fittings.

	P/N	Description
	LM52-1400	2" NPT x 1" NPT (Sch. 40)
	LM52-1800	2" NPT x 1" NPT (Sch. 80)
	LM52-1410	2" Socket x 1" NPT (Sch. 40)
	LM52-1810	2" Socket x 1" NPT (Sch. 80)
	LM52-1850	1" NPT Flange - 150# (Sch. 80)
	LM50-1001-1	1" NPT Bracket, Polypropylene



SCIGATE AUTOMATION (S) PTE LTD
 No.1 Bukit Batok Street 22 #01-01 Singapore 659592
 Tel: (65) 6561 0488 Fax: (65) 6562 0588
 Email: sales@scigate.com.sg Web: www.scigate.com.sg
 Business Hours: Monday - Friday 8.30am - 6.15pm

Ordering

DX10-

- Process mount (1)**
 0 NPT (US)
 1 G (Metric)
Fob USB adapter (2)
 0 Without Fob
 1 With Fob

Notes

- 1) Install the level sensor using Flowline installation fittings or equivalents.
- 2) The level sensor is configured via our WebCal software and one LI99-1001 Fob USB adapter. The level sensor is offered with and without a Fob. Fobs are universal and can be used to configure any WebCal compatible product. WebCal is a free download from our website at www.flowline.com/webcal.php.