

# EchoPro® LR16

Pulse Radar Liquid Level Transmitter



## Application

The intrinsically safe 26 GHz. pulse radar transmitter provides continuous level measurement up to 98.4' (30m) with a 4-20 mA analog and HART digital signal output, and is configured via its integral push button display module or WebCal software. The non-contact liquid level sensor is intended for petroleum, water, wastewater and diluted chemical storage or process conditions in above or below grade tanks of any material. Select this sensor for **challenging process conditions with low or non-corrosive media**, light surface foam or agitation, higher temperature or pressure, condensation or vapor, and installation in a tank adapter, flange fitting or metal stand-pipe. Typical applications include bulk storage, tanker truck, RO storage, process tank, waste sump and neutralization tanks.



**SCIGATE AUTOMATION (S) PTE LTD**  
No.1 Bukit Batok Street 22 #01-01 Singapore 659592  
Tel: (65) 6561 0488 Fax: (65) 6562 0588  
Email: sales@scigate.com.sg Web: www.scigate.com.sg  
Business Hours: Monday - Friday 8.30am - 6.15pm

## Features

- Rugged 316L stainless steel antenna and process mount
- Configuration via push button display or WebCal software
- 26 GHz. pulse radar is unaffected by vapor or condensation
- 12" (30cm) dead band enables utilization of the entire tank
- LCD displays level in feet or meters with percent of span bar
- Optional display mode indicates the echo signal return curve
- HART communication in point to point and multi-drop modes
- Fail-safe diagnostics with selectable signal fail-safe outputs
- Recognition, storage and rejection of false echo signal returns
- IP67 stainless enclosure with polycarbonate display window



LR16-5021-20-00  
Shown

## Antenna Selection

The sensor is offered in three antenna sizes including 2" (48mm), 3" (78mm) and 4" (98mm). The larger the antenna, the narrower the beam and the stronger the RF signal return. To select the appropriate antenna size, consider four variables: the height of the tank, the amount of unobstructed measurement space under the sensor, the thickness of any surface foam and the dielectric of the liquid. In general, the taller the tank, the lesser the free measurement space, the thicker the surface foam or with dielectric values less than 10, consider an increasingly larger antenna.



LR16-5021-30-00  
Shown



Push Button  
Display Module

# EchoPro<sup>®</sup> LR16

Pulse Radar Liquid Level Transmitter



## Specifications

<b>Range:</b>	12" to 98.4' (30cm to 30m)
<b>Frequency:</b>	26 GHz.
<b>Accuracy:</b>	± 3mm
<b>Dead band:</b>	12" (30cm)
<b>Beam angle:</b>	-20: 18° -30: 12° -40: 8°
<b>Configuration:</b>	Push button; WebCal <sup>®</sup> PC Windows <sup>®</sup> USB <sup>®</sup> 2.0; HART 7 (pending)
<b>Memory:</b>	Non-volatile
<b>Display type:</b>	LCD, dot matrix
<b>Display units:</b>	Feet and meters
<b>Display bar:</b>	Percent of span
<b>Display graph:</b>	Echo signal curve
<b>Supply voltage:</b>	21.6 to 26.4 VDC
<b>Max. consumption:</b>	22.5 mA
<b>Signal output:</b>	4-20 mA, two-wire, HART 7
<b>Signal invert:</b>	4-20 mA, 20-4 mA
<b>Signal fail-safe:</b>	3.9 mA, 20.5 mA, 22 mA
<b>Process temp.:</b>	F: -40° to 302° C: -40° to 150°
<b>Temp. comp.:</b>	Automatic
<b>Storage temp.:</b>	F: -40° to 176° C: -40° to 80°
<b>Pressure:</b>	-14.5 to 150 psi (-1 to 10 bar)
<b>Enclosure rating:</b>	IP67
<b>Encl. material:</b>	316L stainless steel w/silicone gasket
<b>Encl. window mat.:</b>	Polycarbonate
<b>Conduit entrance:</b>	(1) 1/2" NPT connector
<b>Antenna material:</b>	316L
<b>Process mount:</b>	1-1/2" NPT
<b>Classification:</b>	Intrinsically safe
<b>Approvals (pending):</b>	ATEX  IIG Ex ia II C T6...T3 Ga IEC Ex ia IIC T6...T3 Ga CSA Class I, Div 1, Groups A, B, C & D; Class II, Groups E, F & G; Class I
<b>Certification:</b>	Zone 0 IIC & Zone 20 Group IIC
<b>Compliance:</b>	FCC CE, CRN, RoHS

## Dimensions

### ANTENNA

P/N	X	Y
- 20	2" (48mm)	5.51" (140mm)
- 30	3" (78mm)	8.94" (227mm)
- 40	4" (98mm)	11.34" (288mm)

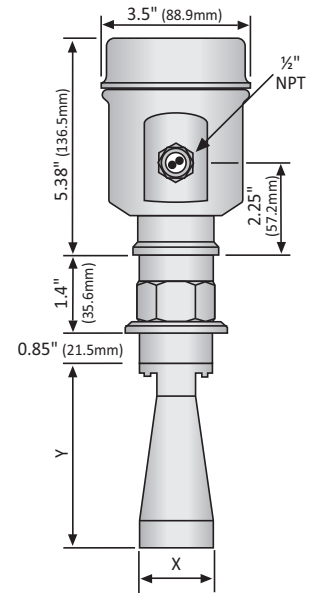

## Fittings

### REDUCER BUSHINGS

<b>LM53-2400</b>	2" x 1.5" NPT, PVC, schedule 40
<b>LM53-2800</b>	2" x 1.5" NPT, PVC, schedule 80
<b>LM53-3800</b>	3" x 1.5" NPT, PVC, schedule 80
<b>LM53-2S10</b>	2" x 1.5" NPT, 316 stainless



LM53-2S10



LM53-2800

### ANSI FLANGES | SS

<b>LM53-3S50</b>	3" x 1.5" NPT, 316 stainless
<b>LM53-4S50</b>	4" x 1.5" NPT, 316 stainless
<b>LM53-6S50</b>	6" x 1.5" NPT, 316 stainless



LM53-4S50

### ANSI FLANGES | CPVC

<b>LM53-3850</b>	3" x 1.5" NPT, CPVC, schedule 80
<b>LM53-4850</b>	4" x 1.5" NPT, CPVC, schedule 80
<b>LM53-6850</b>	6" x 1.5" NPT, CPVC, schedule 80



LM53-3850

## Ordering

LR16-5021-  0-0

### ANTENNA SIZE (1) (2)

2	2" (48mm) horn
3	3" (78mm) horn
4	4" (98mm) horn

### FOB USB ADAPTER (3)

0	Without Fob
1	With Fob

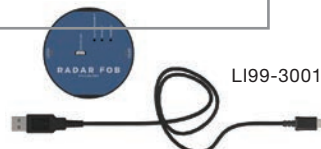

## NOTES

- 1) If you want help in selecting a sensor for your application, please go to our website and submit a Level Questionnaire. An engineer will review your requirements and suggest a product solution via email.
- 2) To install the sensor with a flange or reducer bushing, order the fitting separately, and follow the antenna preparation instructions in the manual.
- 3) Sensors are offered with or without a LI99-3001 Fob USB adapter. If you want to configure the sensor using our free WebCal software, you need one Fob, which can be used with any EchoPro sensor.