

EchoPro® LR21

Pulse Radar Liquid Level Transmitter



Application

The intrinsically safe 26 GHz. pulse radar transmitter provides continuous level measurement up to 65.6' (20m) with a 4-20 mA analog and HART digital signal output, and is configured via its integral push button display module or WebCal software. The non-contact liquid level sensor is intended for chemical storage or process applications in above or below grade tanks of any material. Select this sensor for **challenging process conditions with corrosive media**, light surface foam or agitation, higher temperature or pressure, condensation or vapor, and installation in a flange fitting. Typical applications include bulk storage and process tanks.



SCIGATE AUTOMATION (S) PTE LTD

No. 1 Bukit Batok Street 22 #01-01 Singapore 659592

Tel: (65) 6561 0488

Fax: (65) 6562 0588

Email: sales@scigate.com.sg

Web: www.scigate.com.sg

Business Hours: Monday - Friday 8.30am - 6.15pm

Features

- 316L antenna with PTFE inner shield for corrosive media
- Configuration via push button display or WebCal software
- 26 GHz. pulse radar is unaffected by vapor or condensation
- 12" (30cm) dead band enables utilization of the entire tank
- LCD displays level in feet or meters with percent of span bar
- Optional display mode indicates the echo signal return curve
- HART communication in point to point and multi-drop modes
- Fail-safe diagnostics with selectable signal fail-safe outputs
- Recognition, storage and rejection of false echo signal returns
- IP67 stainless enclosure with polycarbonate display window

PTFE Shield

Sulfuric and nitric acids are strong mineral acids that are widely used in industrial and commercial applications. Highly vaporous and corrosive, they're difficult to measure and harsh on equipment. The non-contact LR21 is an excellent choice for this media, as its 26 GHz. pulse radar measurement is unaffected by extreme vapor, and the antenna's PTFE inner shield, provides reliable corrosion resistance.



LR21-5321-30-00
Shown



Push Button
Display Module

EchoPro[®] LR21

Pulse Radar Liquid Level Transmitter



Specifications

Range:	12" to 65.6' (30cm to 20m)
Frequency:	26 GHz.
Accuracy:	± 3mm
Dead band:	12" (30cm)
Beam angle:	-30: 12° -40: 8°
Configuration:	Push button; WebCal [®] PC Windows [®] USB [®] 2.0; HART 7 (pending)
Memory:	Non-volatile
Display type:	LCD, dot matrix
Display units:	Feet and meters
Display bar:	Percent of span
Display graph:	Echo signal curve
Supply voltage:	21.6 to 26.4 VDC
Max. consumption:	22.5 mA
Signal output:	4-20 mA, two-wire, HART 7
Signal invert:	4-20 mA, 20-4 mA
Signal fail-safe:	3.9 mA, 20.5 mA, 22 mA
Process temp.:	F: -40° to 302° C: -40° to 150°
Temp. comp.:	Automatic
Storage temp.:	F: -40° to 176° C: -40° to 80°
Pressure:	-14.5 to 72 psi (-1 to 5 bar)
Enclosure rating:	IP67
Encl. material:	316L stainless steel w/silicone gasket
Encl. window mat.:	Polycarbonate
Conduit entrance:	(1) 1/2" NPT connector
Antenna material:	316L w/PTFE inner shield
Process mount:	- 30: 3" flange (ANSI) - 40: 4" flange (ANSI)
Classification:	Intrinsically safe
Approvals (pending):	ATEX IIG Ex ia II C T6...T3 Ga IEC Ex ia IIC T6...T3 Ga CSA Class I, Div 1, Groups A, B, C & D; Class II, Groups E, F & G; Class I Zone 0 IIC & Zone 20 Group IIC
Certification:	FCC
Compliance:	CE, CRN, RoHS

Dimensions

FLANGE / ANTENNA

P/N	-30	-40
A	3" ANSI	4" ANSI
B	7.5" (190.5mm)	9" (228.6mm)
C	0.88" (22.3mm)	0.88" (22.3mm)
D	9" (228.6mm)	10.5" (266.7mm)



LI99-3001
Fob USB
Adapter



Echo Signal Return Curve

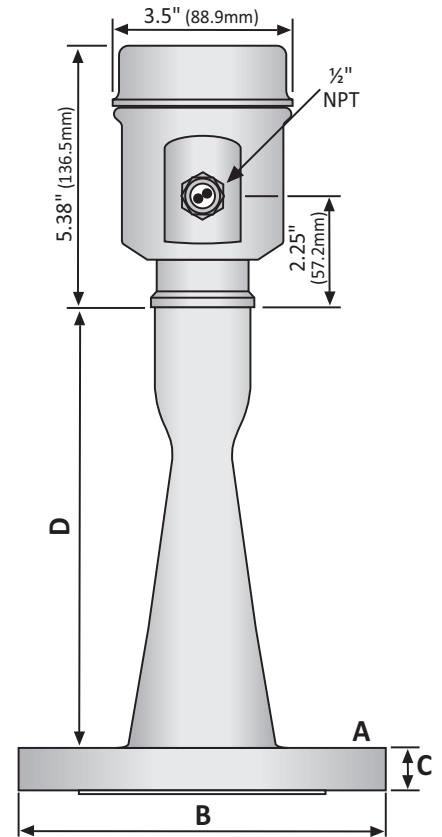

Level Indicator



LI25-2001

DATALOOP[™]

Intrinsically Safe Level Indicator

FM and CSA approved intrinsically safe, the loop powered level indicator displays engineering units connected in series with one 4-20 mA level transmitter. Select the LI25-2001 level indicator for hazardous applications with an intrinsically safe sensor. For field mount installation, add a single or two indicator NEMA box.

Ordering

LR21-5321- 0-0

FLANGE SIZE (1)

3	3" ANSI
4	4" ANSI

FOB USB ADAPTER (2)

0	Without Fob
1	With Fob

NOTES

- 1) If you want help in selecting a sensor for your application, please go to our website and submit a Level Questionnaire. An engineer will review your requirements and suggest a product solution via email.
- 2) Sensors are offered with or without a LI99-3001 Fob USB adapter. If you want to configure the sensor using our free WebCal software, you need one Fob, which can be used with any EchoPro sensor.