

ACCESSORIES

MALE ROD END BEARING W/ JAM NUT

Drawing Number: FI1197-A

INCH [mm] | Material: ZINC PLATED STEEL



SCIGATE AUTOMATION (S) PTE LTD

No.1 Bukit Batok Street 22 #01-01 Singapore 659592

Tel: (65) 6561 0488

Fax: (65) 6562 0588

Email: sales@scigate.com.sg

Web: www.scigate.com.sg

Business Hours: Monday - Friday 8.30am - 6.15pm

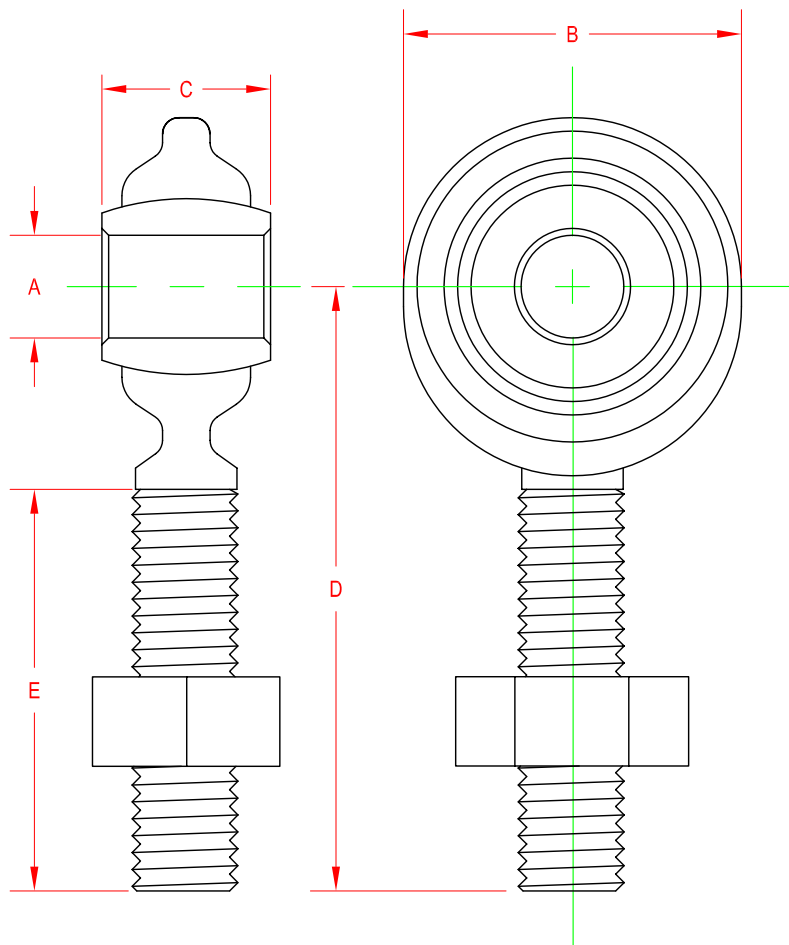

ITEM#	THREAD	A	B	C	D	E	LOAD RATING (lb)
FSH02328	10-32	0.19 [4.8]	0.63 [16.0]	0.31 [7.9]	1.25 [31.8]	0.75 [19.1]	1200
FSH02329	1/4-28	0.25 [6.4]	0.75 [19.1]	0.38 [9.7]	1.56 [39.6]	1.00 [25.4]	2200
FSH02330	5/16-24	0.31 [7.9]	0.88 [22.4]	0.44 [11.2]	1.88 [47.8]	1.25 [31.8]	3600
FSH02331	3/8-24	0.38 [9.7]	1.00 [25.4]	0.50 [12.7]	1.94 [49.3]	1.25 [31.8]	5100
FSH02332	7/16-20	0.44 [11.2]	1.13 [28.7]	0.56 [14.2]	2.13 [54.1]	1.38 [35.1]	6400
FSH02333	1/2-20	0.50 [12.7]	1.31 [33.3]	0.63 [16.0]	2.44 [62.0]	1.50 [38.1]	8300
FSH02334	5/8-18	0.63 [16.0]	1.50 [38.1]	0.75 [19.1]	2.63 [66.8]	1.63 [41.4]	9800
FSH02335	3/4-16	0.75 [19.1]	1.75 [44.5]	0.88 [22.4]	2.88 [73.2]	1.75 [44.5]	14200
FSH02336	1 1/4-12	1.00 [25.4]	2.75 [69.9]	1.38 [35.1]	4.13 [104.9]	2.13 [54.1]	43500
FSH02337	M6 X 1	0.24 [6.0]	0.75 [19.0]	0.35 [9.0]	1.42 [36.0]	0.87 [22.0]	1600
FSH02338	M10 X 1.5	0.39 [10.0]	1.06 [27.0]	0.55 [14.0]	1.89 [48.0]	1.14 [29.0]	4700
FSH02339	M12 X 1.75	0.47 [12.0]	1.18 [30.0]	0.63 [16.0]	2.13 [54.0]	1.30 [33.0]	5800
FSH02340	M16 X 2	0.63 [16.0]	1.50 [38.0]	0.83 [21.0]	2.60 [66.0]	1.57 [40.0]	8400

BALL JOINT HANDLES UP TO 17° OF MISALIGNMENT



This drawing is submitted solely for the information and exclusive use of the original addressee. It is not to be divulged in whole or in part, by any firm or individual without written permission from FUTEK

10 THOMAS
IRVINE, CA 92618 USA
1-800-23-FUTEK (38835)

INTERNET:
<http://www.futek.com>