

FUTEK MODEL QLA381

ITEM NUMBER: TPS01007

MINIATURE INLINE THREADED LOAD SENSOR w/ ANALOG OUTPUTS

INCH [mm] | R.O.= Rated Output

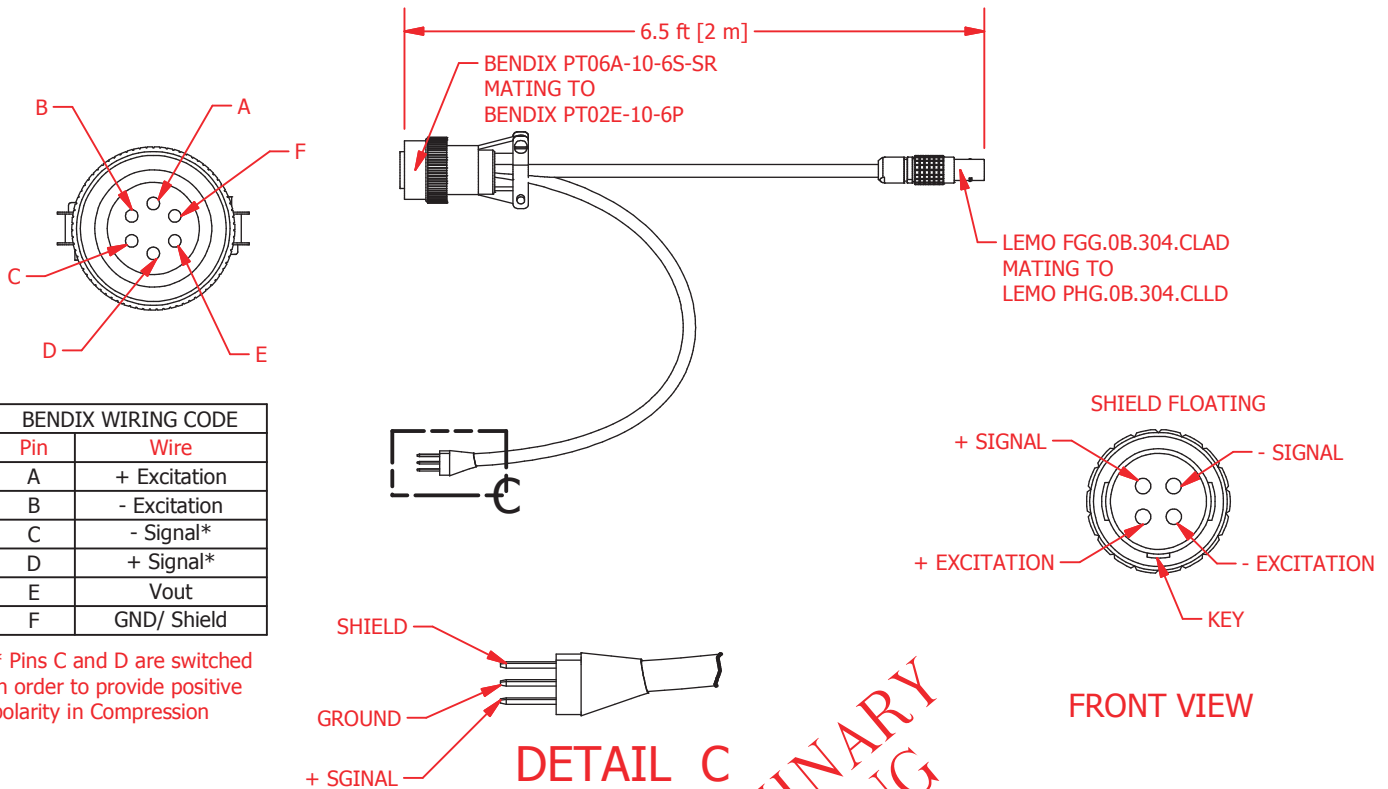

BENDIX WIRING CODE	
Pin	Wire
A	+ Excitation
B	- Excitation
C	- Signal*
D	+ Signal*
E	Vout
F	GND/ Shield

* Pins C and D are switched in order to provide positive polarity in Compression

PRELIMINARY
DRAWING

Wire Colors	
Red	—
Black	—
Green	—
White	—

SCIGATE AUTOMATION (S) PTE LTD
 No.1 Bukit Batok Street 22 #01-01 Singapore 659592
 Tel: (65) 6561 0488 Fax: (65) 6562 0588
 Email: sales@scigate.com.sg Web: www.scigate.com.sg
 Business Hours: Monday - Friday 8.30am - 6.15pm

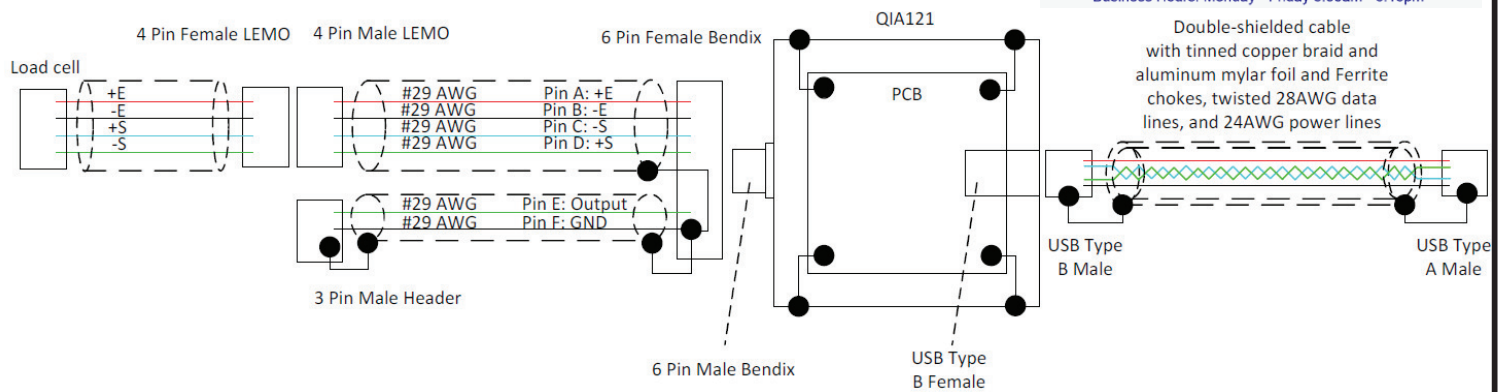

Double-shielded cable with tinned copper braid and aluminum mylar foil and Ferrite chokes, twisted 28AWG data lines, and 24AWG power lines

CUSTOMER APPROVAL- COMPANY:
CUSTOMER APPROVAL- NAME / DATE:
REVISIONS: (Refer to dwg # revision sheet)

OUTLINE DRAWING

STANDARD NOTES: (Unless Otherwise Specified)
 ALL DIMENSIONS ARE IN INCHES
 DRAWING INTERPRETATION DIMS. PER ASME-Y14.5M
 REMOVE BURRS AND BREAK SHARP EDGES .005 - .015
 THREADS PER HANDBOOK H-28
 DIMENSIONS ARE SHOWN AFTER PLATING

ANGLE: ± 1/2°
 CHAMFER: ± 5°
 TOLERANCE:
 .X ± 0.1"
 .XX ± 0.01"
 .XXX ± 0.005"

3rd ANGLE PROJ.

This drawing is submitted solely for the information and exclusive use of the original addressee. It is not to be divulged in whole or in part, by any firm or individual without written permission from:

MODEL: **QLA381**
 DRAWN BY: *E. Pano*
 APPROVED BY: *R. Walker*
 CHECKED BY: *B. F. Moqhaddam*

FUTEK

ADVANCED SENSOR TECHNOLOGY, INC.
 10 THOMAS, IRVINE, CA 92618 USA
 Phone: (949) 465-0900
 Fax: (949) 465-0905

DWG No.: **F01378-B**
 CREATED DATE: 10/8/2014
 APPROVED DATE: 10/16/2014
 CAGE: 1X8M6 SHEET: 3 OF 3