

FUTEK MODEL LSB200 & QIA121

Robust S-Beam Junior Load Cell with Low Noise, High Speed, and High Resolution USB, and Voltage Output

ITEM NUMBER: TPS01012

INCH [mm] | R.O.= Rated Output

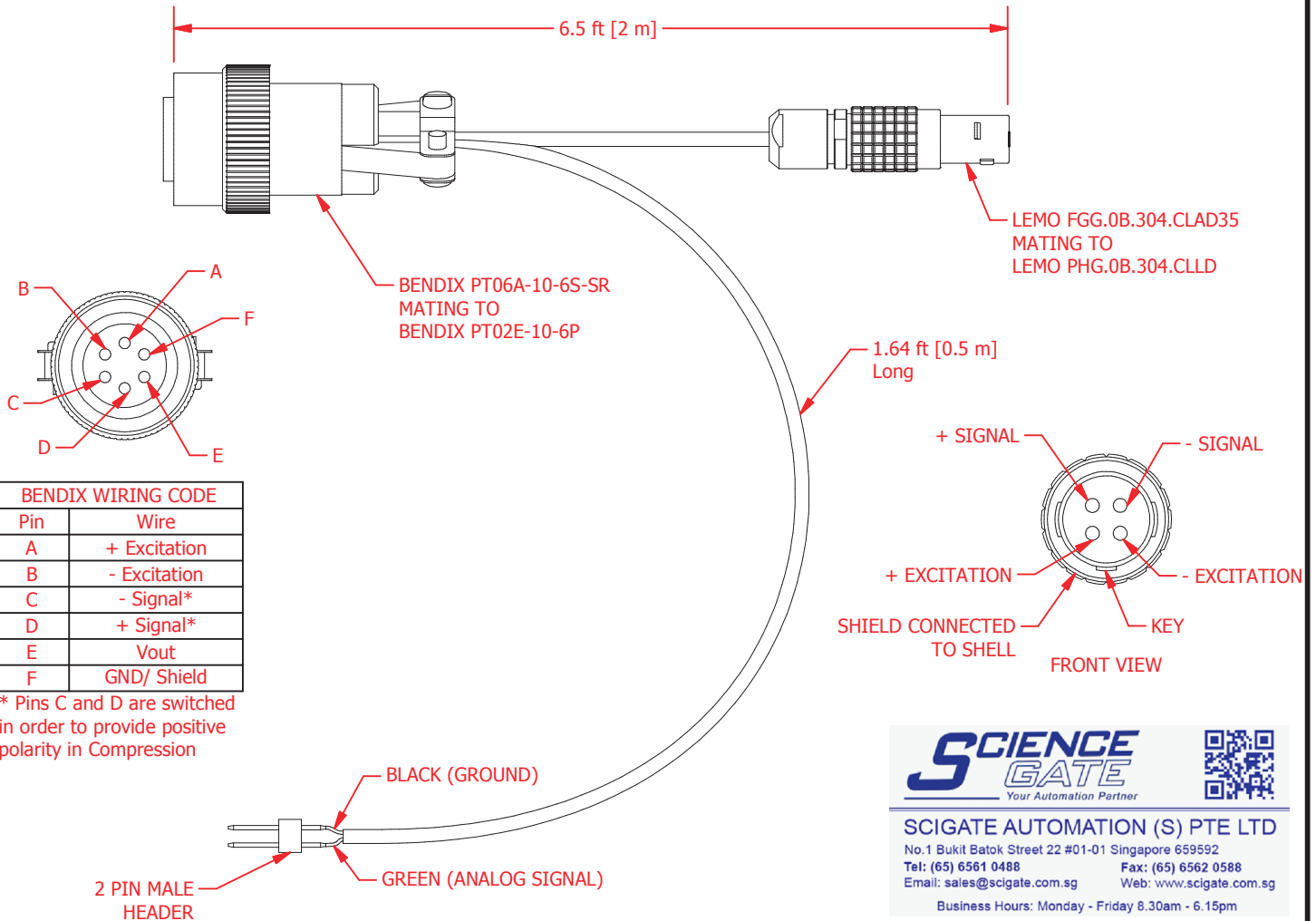
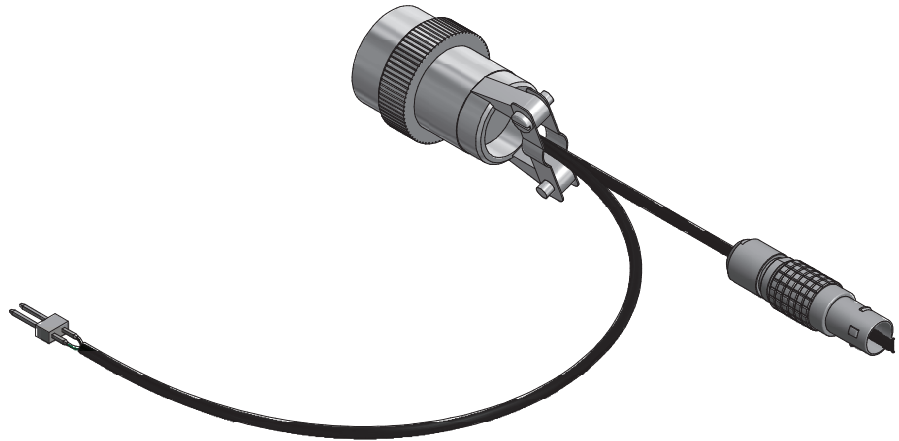

SCIGATE AUTOMATION (S) PTE LTD
 No.1 Bukit Batok Street 22 #01-01 Singapore 659592
 Tel: (65) 6561 0488 Fax: (65) 6562 0588
 Email: sales@scigate.com.sg Web: www.scigate.com.sg
 Business Hours: Monday - Friday 8.30am - 6.15pm

CUSTOMER APPROVAL- COMPANY:

CUSTOMER APPROVAL- NAME / DATE:

REVISIONS: (Refer to dwg # revision sheet)

OUTLINE DRAWING

STANDARD NOTES: (Unless Otherwise Specified)

ALL DIMENSIONS ARE IN INCHES

DRAWING INTERPRETATION DIMS. PER ASME-Y14.5M

REMOVE BURRS AND BREAK SHARP EDGES .005 - .015

THREADS PER HANDBOOK H-28

DIMENSIONS ARE SHOWN AFTER PLATING

ANGLE: ± 1/2°

CHAMFER: ± 5°

3rd ANGLE PROJ.

TOLENANCE:
 .X ± 0.1"
 .XX ± 0.01"
 .XXX ± 0.005"

FUTEK
 ADVANCED SENSOR TECHNOLOGY, INC.
 10 THOMAS, IRVINE, CA 92618 USA
 Phone: (949) 465-0900
 Fax: (949) 465-0905

This drawing is submitted solely for the information and exclusive use of the original addressee. It is not to be divulged in whole or in part, by any firm or individual without written permission from:

MODEL: **LSB200 & QIA121** DWG No.: **FO1381**

DRAWN BY: *E. Pano* CREATED DATE: *9/20/2013*

APPROVED BY: _____ APPROVED DATE: _____

CHECKED BY: _____ CAGE: 1X8M6 SHEET: 3 OF 3