

# ACCESSORIES

# FEMALE ROD END BEARING

Drawing Number: FI1198

INCH [mm] | Material: Zinc Plated Steel



SCIGATE AUTOMATION (S) PTE LTD  
 No. 1 Bukit Batok Street 22 #01-01 Singapore 659592  
 Tel: (65) 6561 0488 Fax: (65) 6562 0588  
 Email: sales@scigate.com.sg Web: www.scigate.com.sg  
 Business Hours: Monday - Friday 8.30am - 6.15pm

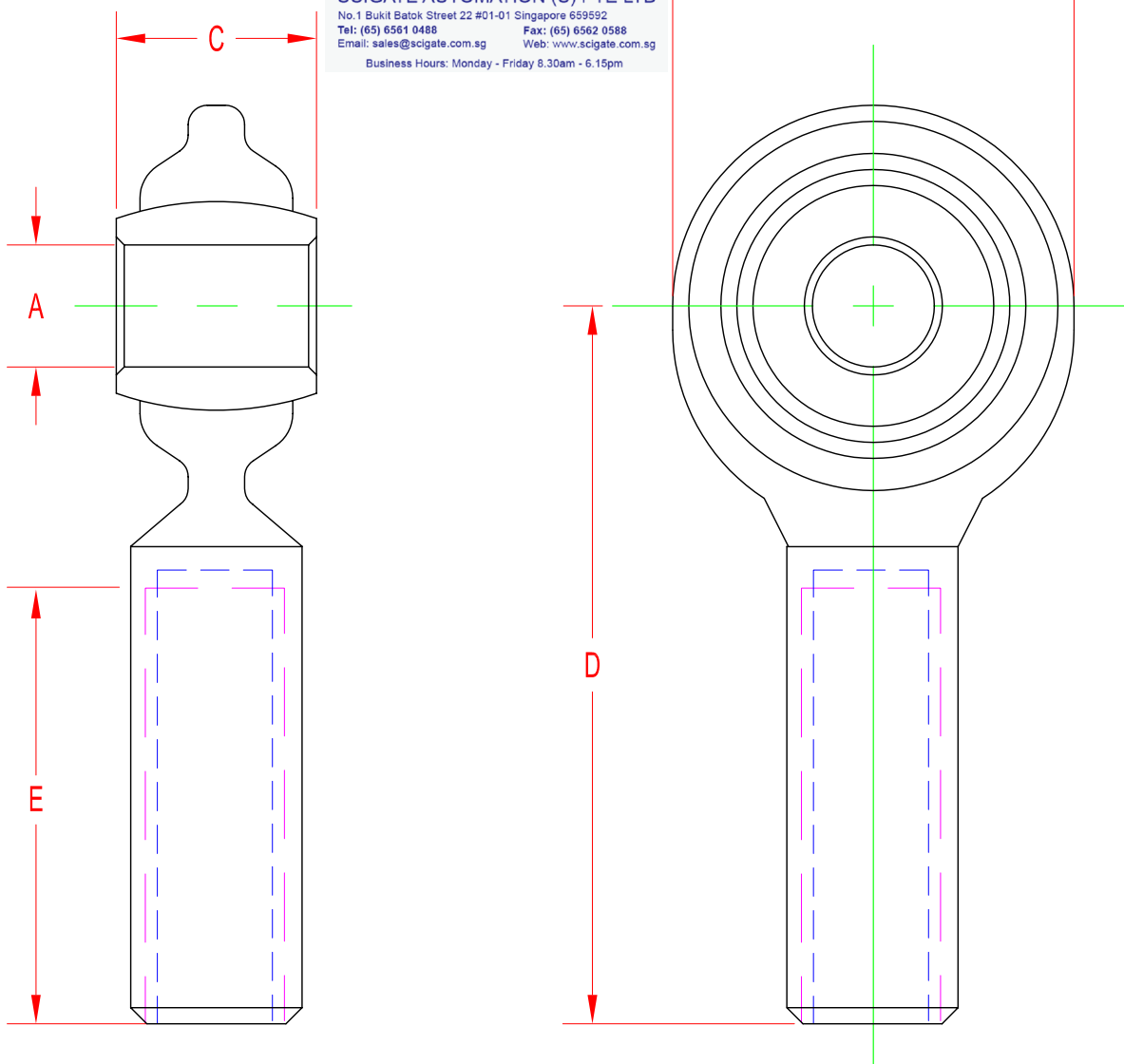

STK#	THREAD	A	B	C	D	E	LOAD RATING (lb)
GOD00727	10-32	0.19 [4.8]	0.63 [16.0]	0.31 [7.9]	1.06 [27.0]	0.50 [12.7]	1500
GOD00728	1/4-28	0.25 [6.4]	0.75 [19.1]	0.38 [9.7]	1.31 [33.3]	0.69 [17.5]	2400
GOD00729	5/16-24	0.31 [7.9]	0.88 [22.4]	0.44 [11.2]	1.38 [35.1]	0.69 [17.5]	2900
GOD00730	3/8-24	0.38 [9.7]	1.00 [25.4]	0.50 [12.7]	1.63 [41.4]	0.81 [20.6]	3800
GOD00731	7/16-20	0.44 [11.2]	1.13 [28.7]	0.56 [14.2]	1.81 [46.0]	0.94 [24.0]	4800
GOD00732	1/2-20	0.50 [12.7]	1.31 [33.3]	0.63 [16.0]	2.13 [54.1]	1.06 [27.0]	6800
GOD00733	5/8-18	0.63 [16.0]	1.50 [38.1]	0.75 [19.1]	2.50 [63.5]	1.38 [35.1]	7300
GOD00734	3/4-16	0.75 [19.1]	1.75 [44.5]	0.88 [22.4]	2.88 [73.2]	1.56 [39.6]	10600
GOD00735	1 1/4-12	1.00 [25.4]	2.75 [69.9]	1.38 [35.1]	4.13 [104.9]	2.13 [54.1]	32600
GOD00736	M6 X 1	0.24 [6.0]	0.75 [19.1]	0.35 [9.0]	1.18 [30.0]	0.55 [14.0]	2000
GOD00737	M10 X 1.5	0.39 [10.0]	1.06 [27.0]	0.55 [14.0]	1.69 [43.0]	0.83 [21.0]	3800
GOD00739	M12 X 1.75	0.47 [12.0]	1.18 [30.0]	0.63 [16.0]	1.97 [50.0]	0.94 [24.0]	4300
GOD00738	M16 X 2	0.63 [16.0]	1.50 [38.0]	0.83 [21.0]	2.52 [64.0]	1.30 [33.0]	6300

**BALL JOINT HANDLES UP TO 17° OF MISALIGNMENT**