

# FUTEK MODEL QMA112

# TORQUE AND THRUST THRU HOLE BI-AXIAL SENSOR

STOCK NUMBER: QSH00980

INCH (mm)		R.O.= Rated Output	
<b>WIRING CODE</b>			
+Excitation	-Excitation	+Signal	-Signal
RED	BLACK	GREEN	WHITE
Shield			
Floating			

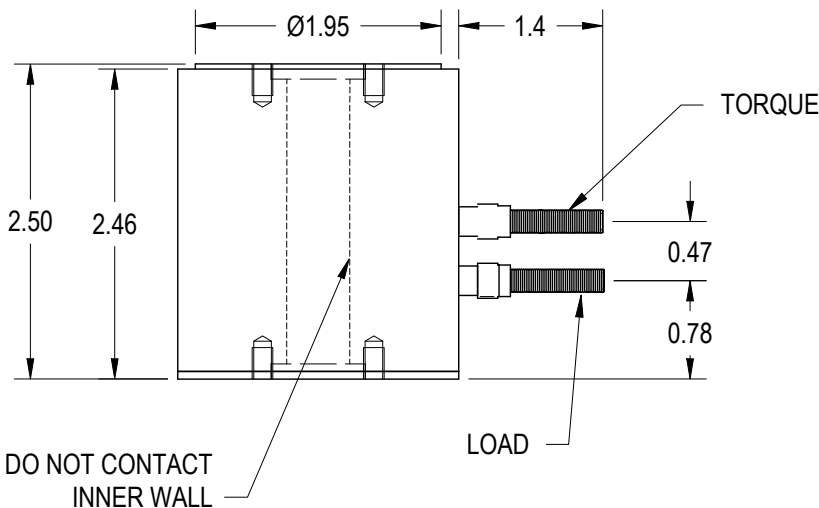
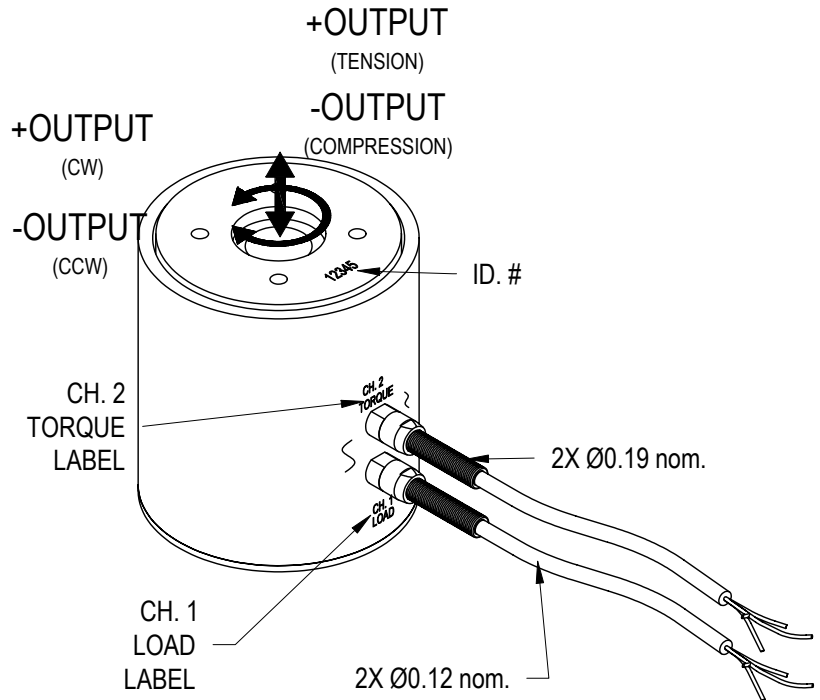
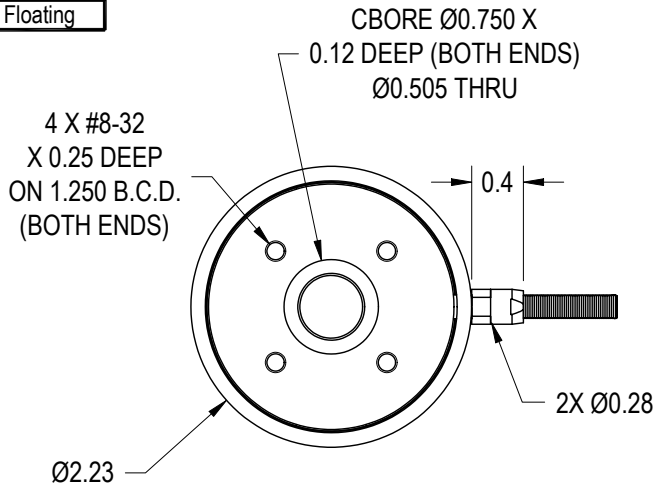

## SPECIFICATIONS:

### Mz and Fz

<b>RATED OUTPUT</b>	2 mV/V nom.
<b>CAPACITY (FZ)</b>	100 lb
<b>CAPACITY (MZ)</b>	50 in-lb
<b>SAFE OVERLOAD</b>	150% of R.O.
<b>ZERO BALANCE</b>	±3% of R.O.
<b>EXCITATION (VDC OR VAC)</b>	18 MAX
<b>BRIDGE RESISTANCE</b>	350 Ω nom.
<b>NONLINEARITY</b>	±0.25% of R.O.
<b>HYSTERESIS</b>	±0.25% of R.O.
<b>NONREPEATABILITY</b>	±0.05% of R.O.
<b>TEMP. SHIFT ZERO</b>	±0.005% of R.O./°F
<b>TEMP. SHIFT SPAN</b>	±0.005% of LOAD/°F
<b>COMPENSATED TEMP.</b>	60 to 160°F
<b>OPERATING TEMP.</b>	-45 to 200°F
<b>MATERIAL</b>	ALUMINUM
<b>CABLE:</b>	#28 AWG, 4 Conductor, Braided Shielded PVC Cable, 10 ft [3 m] Long



### SCIGATE AUTOMATION (S) PTE LTD

No.1 Bukit Batok Street 22 #01-01 Singapore 659592  
 Tel: (65) 6561 0488 Fax: (65) 6562 0588  
 Email: sales@scigate.com.sg Web: www.scigate.com.sg  
 Business Hours: Monday - Friday 8.30am - 6.15pm

MATERIAL:

—

HEAT TREATMENT - FINISH:

—

REVISIONS: (Refer to dwg # revision sheet)

## OUTLINE DRAWING

STANDARD NOTES: (Unless Otherwise Specified)

- ALL DIMENSIONS ARE IN INCHES
- DRAWING INTERPRETATION DIMS. PER ASME-Y14.5M
- REMOVE BURRS AND BREAK SHARP EDGES .005 - .015
- THREADS PER HANDBOOK H-28
- DIMENSIONS ARE SHOWN AFTER PLATING

ANGLE:  
±1/2°

CHAMFER:  
±5°

TOLERANCE:  
.X ±0.1  
.XX ±0.01  
.XXX ±0.005

3rd ANGLE PROJ.



This drawing is submitted solely for the information and exclusive use of the original addressee. It is not to be divulged in whole or in part, by any firm or individual without written permission from:



ADVANCED SENSOR TECHNOLOGY, INC.  
 10 THOMAS  
 IRVINE, CA 92618 USA  
 Phone: (949) 465-0900  
 Fax: (949) 465-0905

**CAGE: 1X8M6**

**MODEL: QMA112**

**DRAWN BY: R. WALKER**

**APPROVED BY: J.V.M**

**DWG No.: FO1188**

**CHECKED BY: -**

**DATE: Aug 21, 2007**