

ACCESSORIES

CHUCK W/ 3/8 SQUARE DRIVE ADAPTER AND CHUCK KEY

Drawing Number: F3759

INCH (mm) MATERIAL: STEEL



SCIGATE AUTOMATION (S) PTE LTD

No.1 Bukit Batok Street 22 #01-01 Singapore 659592
 Tel: (65) 6561 0488 Fax: (65) 6562 0588
 Email: sales@scigate.com.sg Web: www.scigate.com.sg
 Business Hours: Monday - Friday 8.30am - 6.15pm

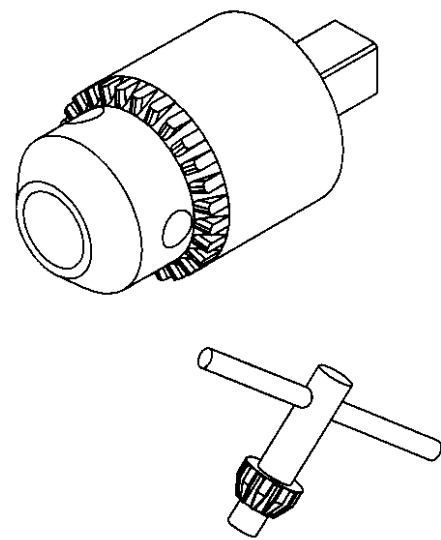
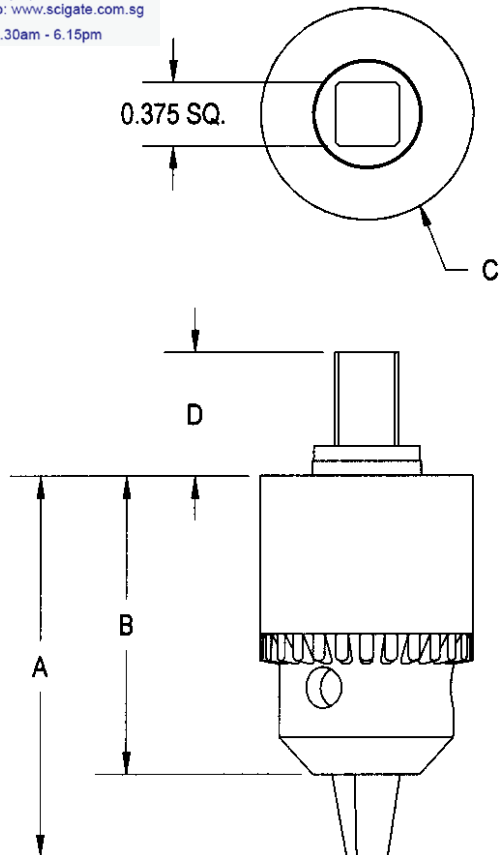

DWG. #	CHUCK SIZE	A	B	C	D
F1416	3/8 [1/16-3/8]	2.25 (57.2)	1.80 (45.7)	1.25 (31.8)	0.66 (16.8)
F2995	1/2 [5/64-1/2]	2.75 (69.9)	2.10 (53.3)	1.60 (40.6)	0.75 (19.1)

APPLICATIONS

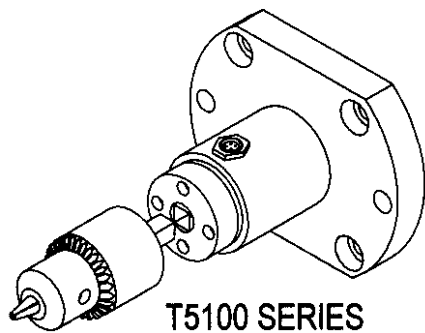
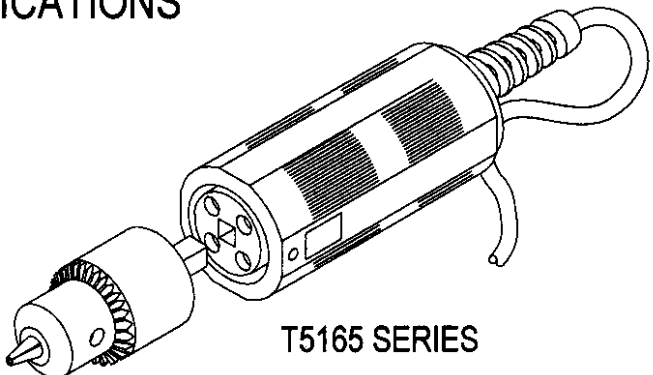

This drawing is submitted solely for the information and exclusive use of the original addressee. It is not to be divulged in whole or in part, by any firm or individual without written permission from FUTEK

10 THOMAS
 IRVINE, CA 92618 USA
 1-800-23-FUTEK (38835)

INTERNET:
<http://www.futek.com>