

User Reference Manual

DuraMON WS 22
DuraMON WS 24
DuraMON WS 27



Disclaimer

ISIC A/S makes no representation or warranties with respect to the contents or use of this manual, and specifically disclaims any express or implied warranties of merchantability or fitness for any particular purpose. Further, ISIC A/S reserves the right to revise this publication and to make changes to its content at any time, without obligation to notify any person or entity of such revisions or changes.

Image sticking: If the monitor is operated with static images (logo's etc) it will inevitably lead to images sticking on the display (like on old CRT's). This is not a permanently situation and can be removed by operating the monitor with a completely black screen.

FCC Warning

Computing devices and peripherals generate and radiate radio frequency energy, and if not installed and used in accordance with the instructions advised by ISIC A/S, it may cause interference to radio communication.

The DuraMON WS series, manufactured by ISIC A/S, is designed to comply with the emerging generic EEC standards, that cover applications in maritime environment.

Classification

The monitor is classified as "protected from the weather" according to IEC 60945 ed.4 (former class b).

Approvals

Approval according to IACS E10 ed. 5 and IEC 60945 ed. 4, Maritime navigation and radio communication equipment and systems – General requirements.



ISIC A/S is complying with the WEEE directive within the European Union, stating that electronic and electric products must be collected separately.

Products are marked according to the directive.

Copyright 2013 ISIC A/S
ISIC PN: 05192-000 rev. B

ISIC A/S
Edwin Rahrsvej 54
DK-8220 Brabrand
Denmark

Phone: +45 70 20 70 77
Fax: +45 70 20 79 76
Web: <http://www.isic-systems.com>



Table of Contents

1	FEATURES.....	4
2	GENERAL CONSIDERATIONS ON INSTALLATION AND OPERATION	5
3	DURAMON WS CONNECTIONS.....	6
4	DURAMON WS FRONT PANEL CONTROLS	7
4.1	DURAMON WS FRONT FOIL.....	7
5	OSD	8
6	SERIAL CONNECTION PIN-OUT	12
7	DURAMON WS COMMUNICATION PROTOCOL.....	12
8	DDC/CI COMMANDS	13
8.1	VCP FUNCTIONS.....	13
9	TECHNICAL SPECIFICATIONS DURAMON WS	14
10	MECHANICAL OUTLINE DURAMON WS 22”	15
11	MECHANICAL OUTLINE DURAMON WS 24”	16
12	MECHANICAL OUTLINE DURAMON WS 27”	17
13	MECHANICAL OUTLINE DURAMON WS BRACKET STAND OPTION	18
14	MECHANICAL OUTLINE DURAMON WS BRACKET WALLMOUNT OPTION.....	19
15	COMPASS SAFE DISTANCE	20
16	POWER CONSUMPTION	20
17	TROUBLESHOOTING	20
18	SERVICING THE UNIT.....	20
19	TERMS, ACRONYMS AND ABBREVIATIONS.....	21
20	ISIC INFO / SUPPORT	22
21	REVISION HISTORY	23
22	APPENDIX A: PIXEL POLICY	24



1 Features

Congratulations on your purchase of a DuraMON WS product. This short form manual is designed to get you started working with your new DuraMON WS.

The DuraMON WS series of monitors are all made as rugged monitors especially designed for the demanding operating conditions at sea.

The DuraMON WS series are tested for full compliance to marine-standards IACS E10 and IEC 60945. The monitor comes with excellent brightness and contrast levels that ensure a good readability thus making it very eye-friendly. For the best picture quality, always use a double shielded DVI cable with ferrites, like the one supplied with the monitor.

Backlight LED technology

Direct dimming control (0-100%) from UP/DOWN buttons.

Full settings control via menu and limited settings over serial link or DDC.

Anti-glare coated glass.

IP65 protection and liquid resistant front.

It is important to notice that, when powered off, the product still consumes some power from the mains. To cut off the power from the product it is necessary to unplug its power cord from the mains.



2 General considerations on Installation and Operation

The DuraMON WS is designed to work at conditions according to IEC 60945. However, keeping the temperature and vibration level at a minimum will extend the life time of the product. ISIC recommend operating this product at normal room temperature (20-25 °C), with the lowest level of vibration and humidity.

Installation of the DuraMON WS

In order to obtain the best possible operating conditions, please note the following precautions.

- Room for cooling.
When designing the cabinet/console for the DuraMON WS, please ensure that air can flow freely around the cabinet, in order to avoid any unnecessary rise in temperature. If it is not possible to have an adequate natural airflow, use a fan to force the airflow to be higher.
- Mounting positions
To obtain adequate cooling by convection ISIC recommends that the DuraMON WS is mounted at least 30 degrees from horizontal. If this is not possible, forced cooling must be applied directly to the unit in order not to overheat it.
- Sunlight
If the unit can be exposed to direct sunlight, there is a potential risk that the unit can be overheated. Please take measures to prevent direct sunlight. Do also consider forced cooling on the back of the unit.



3 DuraMON WS connections

Below is a view of connections to the monitor. The default inputs are: power, RS-232, DVI and VGA.



4 DuraMON WS front panel controls

The front panel is illuminated and will be dimming continuously depending on changing of backlight brightness.

4.1 DuraMON WS front foil

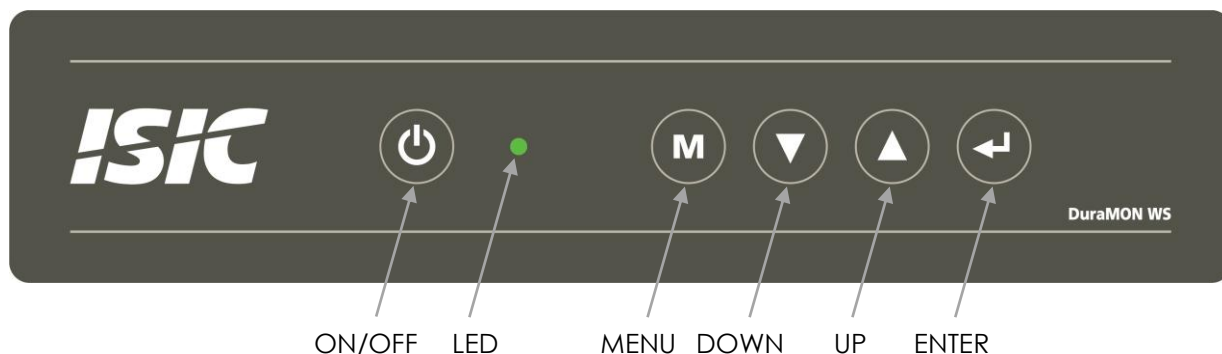

ON/OFF:

This button is used to turn the product on or off. Pressing it will toggle the power. .

LED:

The LED will change color from green to red to indicate power down. LED brightness will decrease with decreasing backlight brightness.

If there is no active input signal, the monitor will display a dialog box to inform the user to check the signal cable.

MENU:

Pressing this button the OSD menu will appear. See OSD section for details.

UP/DOWN:

Used to adjust backlight or to navigate and adjust settings in menus.

ENTER:

This button is used to confirm selections in the OSD menu. If Source isn't set to AUTO in the OSD, use this button to switch to an active source.











5 OSD

With the OSD (On Screen Display) you can modify the settings and control the special features of the DuraMON WS as described on the next pages.

To enter the OSD press "MENU" button.

To navigate the OSD use the "UP" and "DOWN" buttons and press "ENTER" to select a specific setting. To return a previous menu point, press the "MENU" button.

PICTURE	
	PICTURE
	Brightness 50
	Contrast 50
	Sharpness 2
	H Position 50
	V Position 50
	Clock 50
	Phase 55
1280x1024 60Hz	

Brightness:
Use to adjust the Backlight Brightness. Increasing the value will increase the luminance. Decreasing it will decrease the luminance. Be aware that low luminance may inhibit visibility of information on the screen, particularly at night.
Default value = 90

Contrast:
Use to adjust the Contrast. Increasing the value will increase the visibility of dark details in the picture. Decreasing the value will decrease the visibility of dark details in the picture. Be aware that too high or low contrast may inhibit visibility of information on the screen, particularly at night.
Default value = 50

Sharpness:
Use to adjust the Sharpness of the picture. Increasing the value will make the picture more detailed. Decreasing the value will make the picture less detailed.
Default value = 2

H Position (VGA only):
Use to adjust the position of the signal left or right. Increase the value to move the picture right. Decrease the value to move the picture left.
Default value = 50

V Position (VGA only):
Use to adjust the position of the signal up or down. Increase the value to move the picture up. Decrease the value to move the picture down.
Default value = 50

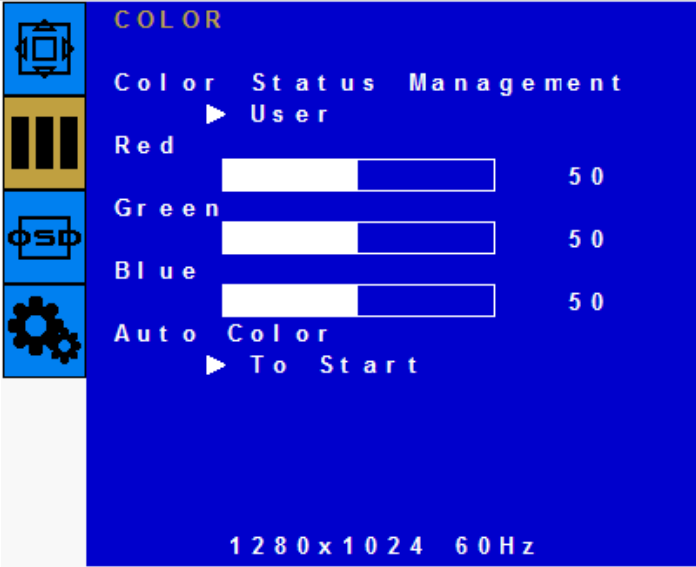

	<p><u>Clock (VGA only):</u> Use to adjust the frequency of the clock signal. Default value = 50</p> <p><u>Phase (VGA only):</u> Use to adjust the clock phase. Adjusting this value will remove shadows in the picture. Default value = Auto detected</p>
--	---

COLOR	
	<p><u>Color Status Management</u> Use to adjust the color temperature of the picture. Default value = User</p> <p><u>Red (VGA only):</u> Use to adjust the Red gain. Increase the value to make the picture more reddish. Decrease to make it less reddish. Default = 50</p> <p><u>Green (VGA only):</u> Use to adjust the Green gain. Increase the value to make the picture more greenish. Decrease to make it less greenish. Default = 50</p> <p><u>Blue (VGA only):</u> Use to adjust the Blue gain. Increase the value to make the picture more bluish. Decrease to make it less bluish. Default = 50</p> <p><u>Auto Color (VGA only):</u> Use to auto adjust the ADC values for Red, Green and Blue.</p>



OSD

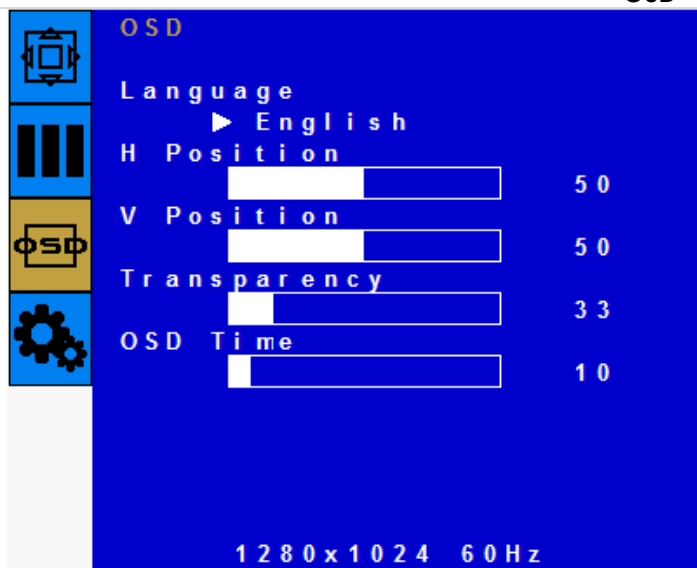

Language:

Use to change the OSD language.
Default: English

H Position:

Use to adjust the position of the OSD menu left or right. Increase the value to move the OSD right. Decrease the value to move the OSD left.

Default value = 50

V Position:

Use to adjust the position of the OSD menu up or down. Increase the value to move the OSD up. Decrease the value to move the OSD down.

Default value = 50

Transparency:

Use to adjust the transparency of the OSD menu. Decreasing the value will make the OSD more transparent. Increasing the value will make the OSD more solid.

Default value = 33

OSD Time:

Use to select how long time the OSD menu will be displayed. When no actions have been carried out in the specified time, the OSD menu will be removed.

Default value = 10 seconds

SETUP



Source:

Use to change the active source. Selecting AUTO will scan for an active signal. If both VGA and DVI signal are found, DVI will be preferred.

Default = Auto

Factory Reset:

Use to restore all settings to the default values. By activating this function, all settings made by the user will be lost and the monitor will be brought back to known operating conditions.



Aspect:

Use to select if aspect ratio should be applied to the picture. Off will stretch the picture to fill the screen. On will fill the screen, but keep the aspect ratio. This will result in black bands on the border of the screen.

Default = Off

Set ID:

Use to enable/disable serial communication through the RS-232 port. Enabling it will allow the user to control settings in the monitor. See the "DuraMON WS communication protocol" section for details.

Default = Off



6 Serial connection pin-out

The pin-out of the serial port SUB-D connector on the rear side of the DuraMON WS is as below:

Pin	RS-232
	SUB-D 9-pol female
1	
2	TX
3	RX
4	
5	GND
6	
7	
8	
9	

Data Rate:

The monitor is configured to transmit and receive data at 9600 bits/second.

Data Format:

Data shall be transmitted with no parity, 8 data bits, one start bit, and one stop bit.

7 DuraMON WS communication protocol

To control the DuraMON WS from a PC the commands below has to be used.

	Function	BYTE0	BYTE1	BYTE2	BYTE3	BYTE4	BYTE5
		Length	Set ID	CMD1	CMD2	CMD3	Checksum
POWER BUTTON	Power On/Off	6	0	'K' (0x4B)	'P' (0x50)	'W' (0x57)	0x08
MENU BUTTON	Menu/Exit	6	0	'K' (0x4B)	'M' (0x4D)	'N' (0x4E)	0x14
ENTER BUTTON	Enter	6	0	'K' (0x4B)	'M' (0x4D)	'O' (0x4F)	0x13
UP BUTTON	Up	6	0	'K' (0x4B)	'M' (0x4D)	'U' (0x55)	0x0D
DOWN BUTTON	Down	6	0	'K' (0x4B)	'M' (0x4D)	'D' (0x44)	0x1E

Checksum : BYTE0 + BYTE1 + BYTE2 + BYTE3 + BYTE4 + BYTE5 = 0

Example:

Decrement backlight level one step (when no OSD is active):

BYTE0	BYTE1	BYTE2	BYTE3	BYTE4	BYTE5
0x06	0x00	0x4B	0x4D	0x44	0x1E

Reply from Monitor:

BYTE0	BYTE1	BYTE2	BYTE3	BYTE4	BYTE5
0x64	0x6F	0x77	0x6E	0x0D	0x0A



8 DDC/CI commands

To avoid the additional serial cable it is also possible to control the DuraMON WS through a DDC/CI (Display Data Channel Command Interface) integrated in the DVI cable/connector.

Data format:

BYTE0	BYTE1	BYTE2	BYTE3	BYTE4	BYTE5	BYTE6	BYTE7
DEST	SOUR	LENG	SET_V	VCP	R/W	VALUE	CHK

DEST	Destination address
SOURCE	Source address
LENGTH	Length
SET_VCP	Set VCP Feature COMMAND
VCP	VCP command to use
R/W	Read or Write
VALUE	Value
CHK	Checksum

8.1 VCP functions

VCP 10h (Backlight brightness)

Value range: 0x00 – 0x5A

Example:

Set Backlight brightness to 0x5A (90%):

BYTE0	BYTE1	BYTE2	BYTE3	BYTE4	BYTE5	BYTE6	BYTE7
0x6E	0x51	0x84	0x03	0x10	0x00	0x5A	0xF2

VCP 12h (Contrast)

Value range: 0x00 – 0x64

Example:

Set Contrast to 0x32 (50%):

BYTE0	BYTE1	BYTE2	BYTE3	BYTE4	BYTE5	BYTE6	BYTE7
0x6E	0x51	0x84	0x03	0x12	0x00	0x32	0x98

VCP E0h (Gamma selection)

0x00	GAMMA_DAY1
0x01	GAMMA_DUSK1
0x02	GAMMA_NIGHT1
0x03	GAMMA_DAY2
0x04	GAMMA_DUSK2
0x05	GAMMA_NIGHT2

Example:

Set Gamma to GAMMA_DUSK1:

BYTE0	BYTE1	BYTE2	BYTE3	BYTE4	BYTE5	BYTE6	BYTE7
0x6E	0x51	0x84	0x03	0xE0	0x00	0x01	0x59



9 Technical specifications DuraMON WS

DuraMON WS

Display sizes:	22", 22" and 27" Wide Screen LCD (TFT)				
Display properties:	Size – Active Area (Aspect)	Luminance	Contrast	Resolution	View angle (L/R/T/B)
Standard Display:	22" – 476.64 x 268.11 (16/9)	250 Cd/m ²	1000:1	1920 x 1080	80/80/80/60
Wide angle Display option:	22" – 476.64 x 268.11 (16/9)	270 Cd/m ²	5000:1	1920 x 1080	89/89/89/89
Standard Display:	24" – 521.28 x 293.22 (16/9)	300 Cd/m ²	1000:1	1920 x 1080	80/80/80/60
Wide angle Display option:	24" – 521.28 x 293.22 (16/9)	250 Cd/m ²	1000:1	1920 x 1080	89/89/89/89
Standard Display:	27" – 597.88 x 336.31 (16/9)	300 Cd/m ²	1200:1	1920 x 1080	80/80/80/60
Wide angle Display option:	27" – 597.88 x 336.31 (16/9)	250 Cd/m ²	1000:1	1920 x 1080	89/89/89/89
Materials:	Front: Sea Water Resistant Aluminium w. black power coating RAL 9005 Rear: Sea Water Resistant Aluminium w. black power coating RAL 9005				
Window:	Anti Reflection coated front glass				
Protection:	IP65 front – IP20 rear (IP 22 with optional rear-cover)				

DuraMON WS I/O

Video inputs:	RGB :	Analogue 0.7 Vpp positive at 75Ω, Separate sync or sync on green Generally all VESA compatible video modes are supported up to 165MHz (up to UXGA 60Hz and WUXGA 60Hz reduced blanking). Horizontal sync: 15-100 kHz (automatic) Vertical sync: 30-85 Hz up to 1280x1024 30-60 Hz up to 1920x1200
	DVI:	Generally all VESA compatible video modes are supported up to 160MHz (up to UXGA 60Hz and WUXGA 60Hz reduced blanking). <i>DDC communication for adjustment for Day / Dusk / Night. (Optional extra)</i>
Control inputs:	1x RS232 – for remote control	

DuraMON WS Power Supply

Standard:	90-264Vac. 50-60Hz Input		
Optional:	18-36Vdc Input		
Power Consumption:	Size	P_{TYP} (Watt)	P_{MAX} (Watt)
	22"	20	35
	24"	25	40
	27"	30	45

DuraMON WS Environmental Conditions

Operating Temperature:	-15 to 55 °C
Storage Temperature:	-25 to 70 °C
Relative Humidity:	8 to 90 %

DuraMON WS Approvals

CE Mark:	EN61000-6-2 & EN61000-6-4
Marine:	IACS E10 Rev. 5 & IEC 60945 Ed. 4 <i>For marine class approvals – see www.isic-systems.com</i>

DuraMON WS Physical dimensions

Size:	22" 552 (W) x 380 (H) x 68 (D)
	24" 601 (W) x 408 (H) x 68 (D)
	27" 684 (W) x 452 (H) x 68 (D)
Weight:	22" 9 kg
	24" 10kg
	27" 11kg
Bracket:	Desk/ceiling- and wall-bracket with IP22 rear-cover available (optional extra)



10 Mechanical outline DuraMON WS 22"

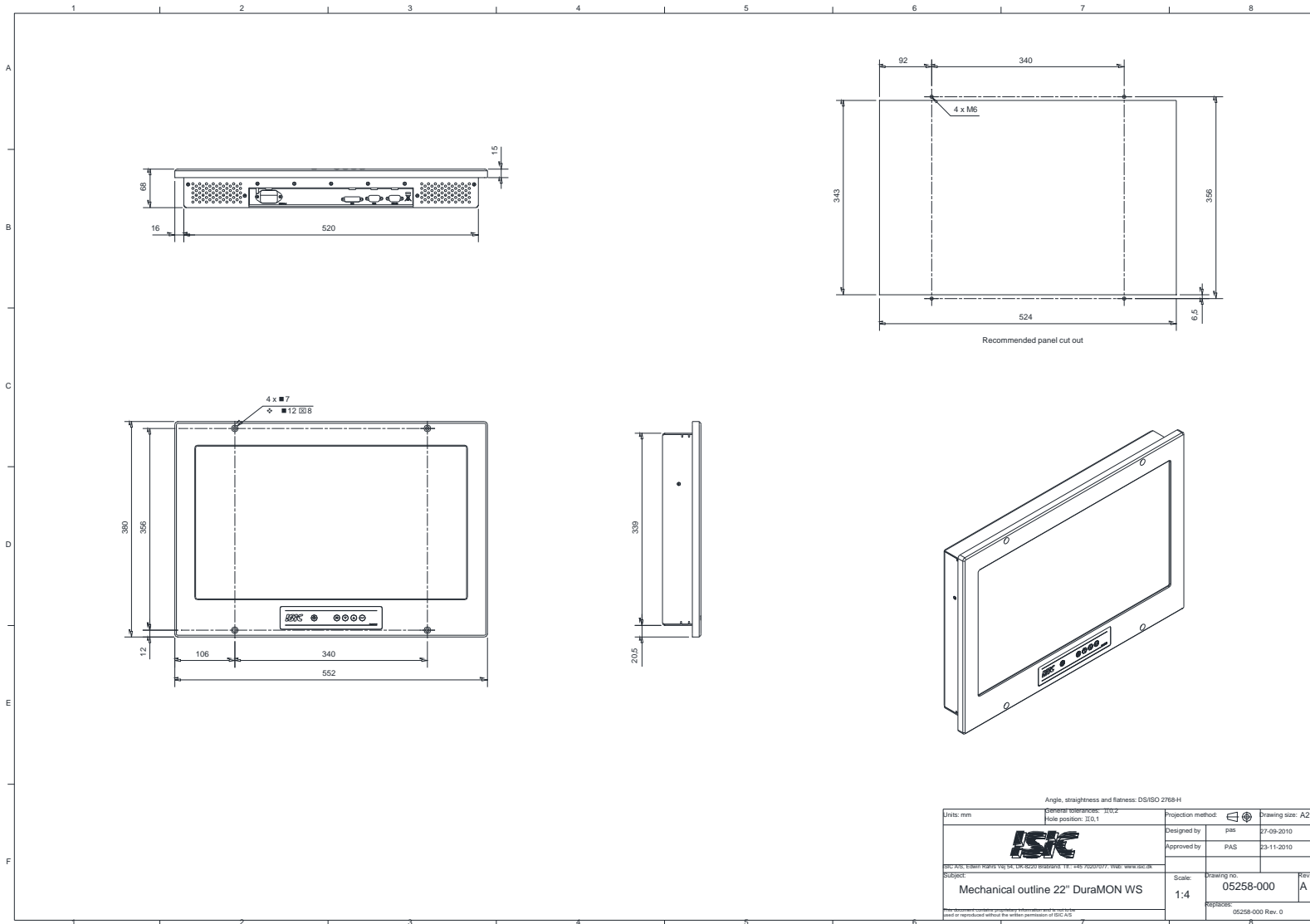

Angle, straightness and flatness: DS/ISO 2768-H

Units: mm	Projection method:	Drawing size: A2
ISO 9001:2015 certified	Designed by: pas	27-09-2010
	Approved by: PAS	23-11-2010
Subject: Mechanical outline 22" DuraMON WS	Scale: 1:4	Drawing no: 05258-000
		Rev: A
		05258-000 Rev. 0



11 Mechanical outline DuraMON WS 24"

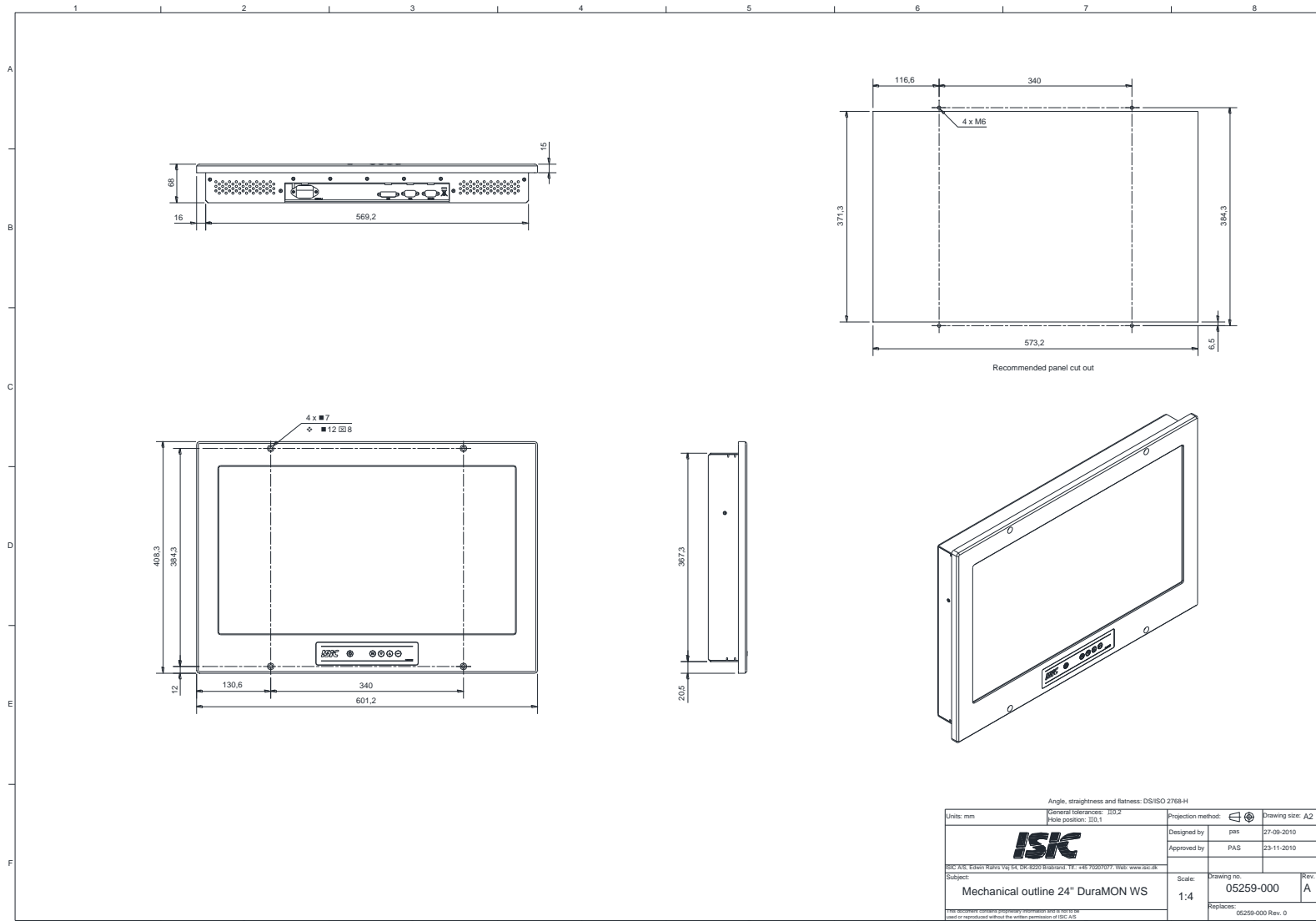

Angle, straightness and flatness: DS/ISO 2768-H

Units: mm	General tolerances: ISO 2 Hole position: ITO, 1	Projection method:	Drawing size: A2
		Designed by: pas	27-09-2010
		Approved by: PAS	23-11-2010
ISK A/S, Edison Røhrs Vej 54, DK-8250 Brabrand 11, +45 70207077, Web: www.isk.dk Subject: Mechanical outline 24" DuraMON WS		Scale: 1:4	Drawing no: 05259-000 Replaces: 05259-000 Rev. 0
<small>THIS DOCUMENT IS A PRELIMINARY REPRESENTATION AND IS NOT TO BE USED OR REPRODUCED WITHOUT THE WRITTEN PERMISSION OF ISK A/S</small>			Rev: A



12 Mechanical outline DuraMON WS 27"

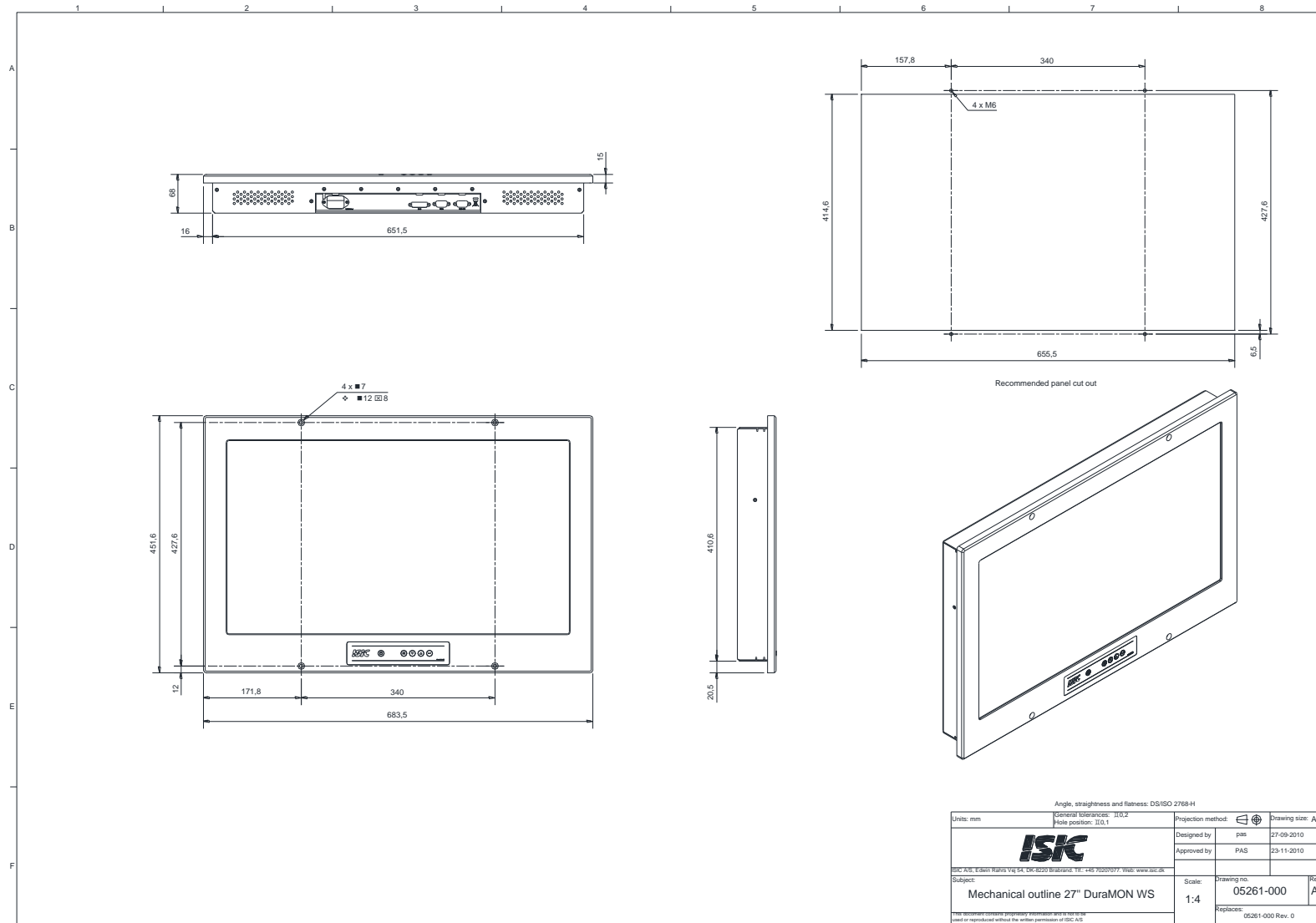

Angle, straightness and fitness: DS/ISO 2768-H

Units: mm	General tolerances: IT02	Projection method:	Drawing size: A2
	Hole position: JD,1	Designed by:	pas 27-09-2010
		Approved by:	PAS 23-11-2010
		Scale:	1:4
Subject: Mechanical outline 27" DuraMON WS		Drawing no.:	05261-000
		Replaces:	05261-000 Rev. 0
<small>This document contains proprietary information and is not to be used for reproduction without the written permission of ISIC S.p.A.</small>		Rev.:	A



13 Mechanical outline DuraMON WS bracket stand option

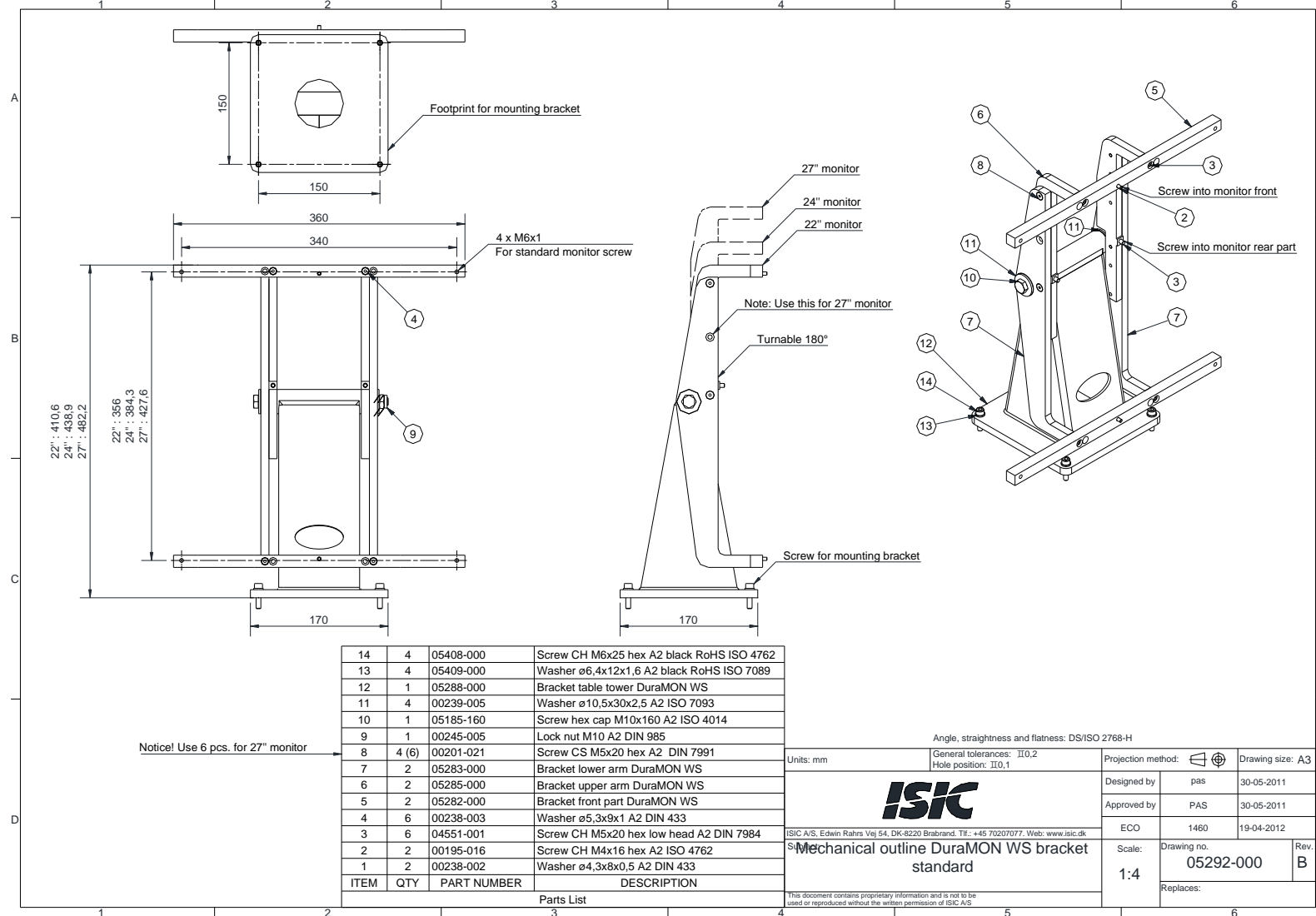

22" : 410,6
24" : 438,9
27" : 482,2

22" : 356
24" : 384,3
27" : 427,6

Notice! Use 6 pcs. for 27" monitor

ITEM	QTY	PART NUMBER	DESCRIPTION
14	4	05408-000	Screw CH M6x25 hex A2 black RoHS ISO 4762
13	4	05409-000	Washer ø6,4x12x1,6 A2 black RoHS ISO 7089
12	1	05288-000	Bracket table tower DuraMON WS
11	4	00239-005	Washer ø10,5x30x2,5 A2 ISO 7093
10	1	05185-160	Screw hex cap M10x160 A2 ISO 4014
9	1	00245-005	Lock nut M10 A2 DIN 985
8	4 (6)	00201-021	Screw CS M5x20 hex A2 DIN 7991
7	2	05283-000	Bracket lower arm DuraMON WS
6	2	05285-000	Bracket upper arm DuraMON WS
5	2	05282-000	Bracket front part DuraMON WS
4	6	00238-003	Washer ø5,3x9x1 A2 DIN 433
3	6	04551-001	Screw CH M5x20 hex low head A2 DIN 7984
2	2	00195-016	Screw CH M4x16 hex A2 ISO 4762
1	2	00238-002	Washer ø4,3x8x0,5 A2 DIN 433

Angle, straightness and flatness: DS/ISO 2768-H

Units: mm

General tolerances: II,0,2
Hole position: II,0,1

Projection method:

Drawing size: A3

Designed by: pas 30-05-2011

Approved by: PAS 30-05-2011

ECO 1460 19-04-2012

Scale: 1:4

Drawing no. 05292-000

Rev. B

Replaces:

ISIC

ISIC A/S, Edwin Rahrs Vej 54, DK-8220 Brabrand, Tlf.: +45 70207077, Web: www.isic.dk

Mechanical outline DuraMON WS bracket standard

This document contains proprietary information and is not to be used or reproduced without the written permission of ISIC A/S



14 Mechanical outline DuraMON WS bracket wallmount option

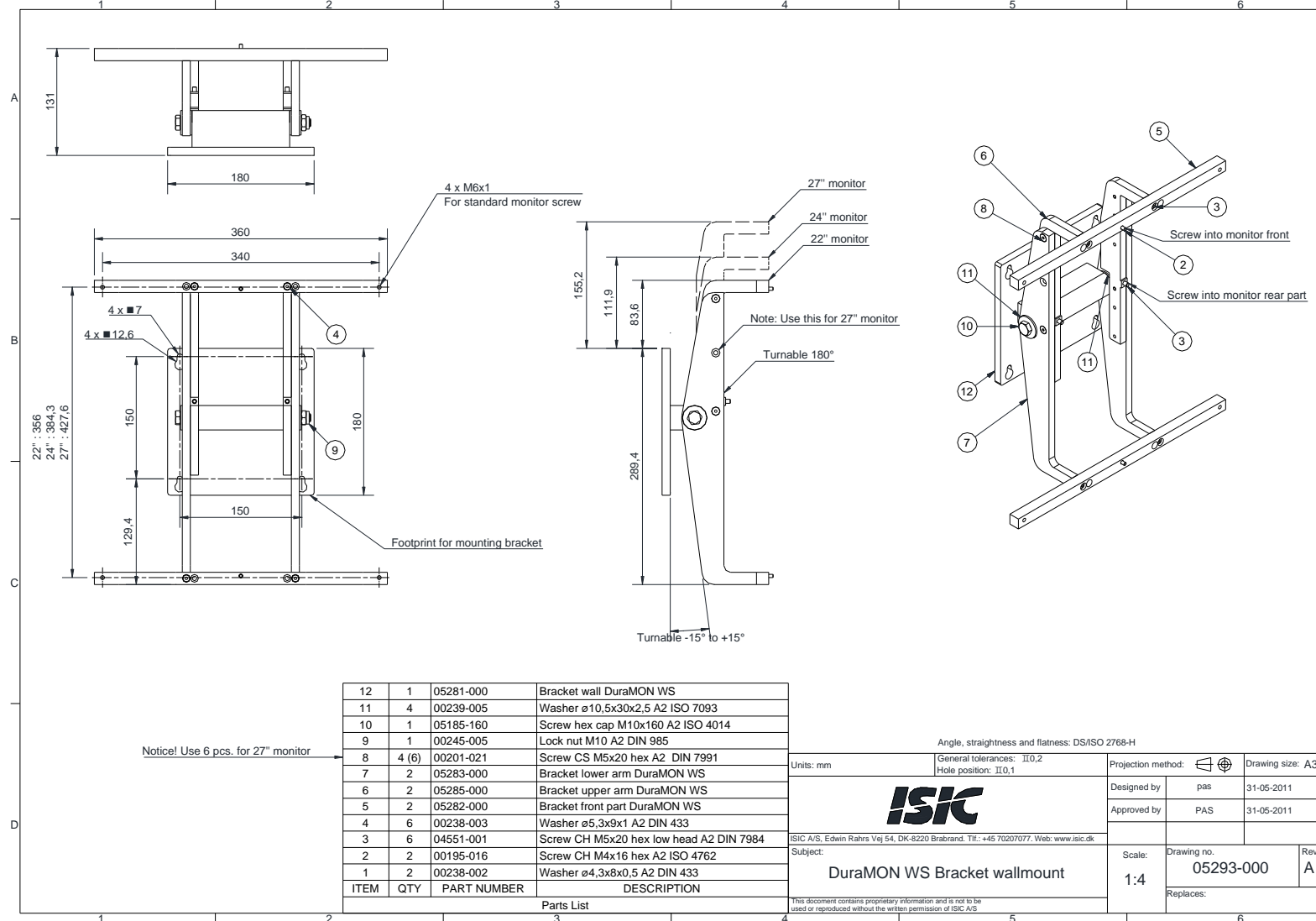

Notice! Use 6 pcs. for 27" monitor

ITEM	QTY	PART NUMBER	DESCRIPTION
12	1	05281-000	Bracket wall DuraMON WS
11	4	00239-005	Washer ø10,5x30x2,5 A2 ISO 7093
10	1	05185-160	Screw hex cap M10x160 A2 ISO 4014
9	1	00245-005	Lock nut M10 A2 DIN 985
8	4 (6)	00201-021	Screw CS M5x20 hex A2 DIN 7991
7	2	05283-000	Bracket lower arm DuraMON WS
6	2	05285-000	Bracket upper arm DuraMON WS
5	2	05282-000	Bracket front part DuraMON WS
4	6	00238-003	Washer ø5,3x9x1 A2 DIN 433
3	6	04551-001	Screw CH M5x20 hex low head A2 DIN 7984
2	2	00195-016	Screw CH M4x16 hex A2 ISO 4762
1	2	00238-002	Washer ø4,3x8x0,5 A2 DIN 433

Angle, straightness and flatness: DS/ISO 2768-H

Units: mm

General tolerances: II,0.2
Hole position: II,0.1

Projection method:

Drawing size: A3

Designed by: pas 31-05-2011

Approved by: PAS 31-05-2011

ISIC A/S, Edwin Rahrs Vej 54, DK-8220 Brabrand. Tlf.: +45 70207077. Web: www.isic.dk

Subject: DuraMON WS Bracket wallmount

Scale: 1:4

Drawing no. 05293-000

Rev. A

Replaces:

This document contains proprietary information and is not to be used or reproduced without the written permission of ISIC A/S.



15 Compass safe distance

Test object / condition	Minimum Compass safe distance [cm] (5.4°/H deviation or a horizontal magnetic flux of 0.094μT)	Minimum Compass safe distance [cm] (18°/H deviation or a horizontal magnetic flux of 0.313μT)
DuraMON WS 22	175	110
DuraMON WS 22 Wide angle	205	135
DuraMON WS 24	265	160
DuraMON WS 24 Wide angle	215	140
DuraMON WS 27	255	125
DuraMON WS 27 Wide angle	250	160

16 Power Consumption

Test object / condition	P _{typ} (Watt)	P _{max} (Watt)
DuraMON WS 22	20	35
DuraMON WS 22 Wide angle	30	45
DuraMON WS 24	25	40
DuraMON WS 24 Wide angle	30	45
DuraMON WS 27	30	45
DuraMON WS 27 Wide angle	30	45

In rush current ac: ~ 40 A max at 230 VAC, cold start 25 °C

17 Troubleshooting

Problem	Cause	Solutions
No picture on display	Backlight level set to minimum	Increase backlight
	Monitor turned off	Turn on the monitor
	No input signal present	Apply signal
	No power cord connected	Apply power
Buttons on front doesn't work	No power cord connected	Apply power
	Keypad defect	Please do not try to open the unit. Send it to ISIC A/S for repair.

18 Servicing the unit

In case that the unit still fails after following the troubleshooting send the unit to ISIC for repair. There are no user serviceable parts inside.



19 Terms, Acronyms and abbreviations

Communication protocol:	Use a serial link to control various settings in the monitor
DVI:	Digital Visual Interface
IP20:	International Protection Rating (protected against objects with a size larger than 12.5mm)
IP65:	International Protection Rating (dust tight and protected against water jerks)
OSD:	On Screen Display
TBD:	To be defined
VGA:	Video Graphics Array



20 ISIC info / Support

In case you have inquiries or problems with your DuraMON WS, you have a number of possibilities to get support.

Company name: ISIC A/S

Head office: Edwin Rahrs Vej 54
DK – 8220 Brabrand
Denmark

Shipping address: Holmstrupgaardvej 5
DK-8220 Brabrand
Denmark

Telephone: +45 70 20 70 77
Fax: +45 70 20 79 76

Mail: mail@isic-systems.com
www: www.isic-systems.com

VAT number: DK 16 70 45 39

Bank Address: Nordea Bank Danmark A/S
Erhvervsafdelingen København Nord
Nørgaardsvej 2
Dk – 2800 Kgs. Lyngby
Denmark

Bank Code: 2228
Account number: 6877575320
IBAN: DK36 2000 6877 5753 20
SWIFT: NDEADKKK

Contacts:
RFQ's: By fax to +45 70 20 79 76
By mail to sales@isic-systems.com

Orders: By fax to +45 70 20 79 76
By mail to orders@isic-systems.com

Support: Via homepage www.isic.dk under aftersales
By mail to service@isic-systems.com
During office-hours (Mo-Fr: CET 0800 - 1600) at +45 70 20 70 77

Service: Before shipment for service request Return Material Authorisation number at homepage www.isic-systems.com under RMA
By mail to service@isic-systems.com



21 Revision history

Rev A	Jan 2011	First release
Rev B	May 2013	Communication settings added Bracket option added Wide angle display specifications added Wide angle display compass safe distance added Front panel dimming description added Pixel policy updated Power consumption updated



22 Appendix A: Pixel policy

ISO 9241-307:2008 guidelines for LCD pixel defects

Introduction

TFT displays consist of a set number of pixels. Each pixel consists of 3 sub-pixels also called dots (one red, one blue and one green). Every sub-pixel is addressed by its own transistor. As a result, the manufacturing of glass substrate is very complex.

Due to the nature of this manufacturing process, occasional defects can occur. Pixel defects or failures cannot be fixed or repaired and may occur at any stage during the service life of the TFT display.

To regulate the acceptability of defects and protect the end user, ISIC A/S complies with the ISO 9241-307:2008 standard. This standard recommends how many defects are considered acceptable in a display, before it should be replaced within the terms of the warranty.

Monitor classification

ISO 9241-307:2008

Allowed defects per type per million pixels						
Defect classes	Pixel defects			Cluster defect		
	Type 1	Type 2	Type 3 total ($2 \times N_{3a} + N_{3b}$)	Type 1	Type 2	Type 3
Class: 0	0	0	0	0	0	0
Class: I	1	1	5	0	0	0
Class: II	2	2	10	0	0	1
Class: III	5	15	100	0	0	5

ISIC TFT monitors comply with ISO 9241-307:2008 Class II.

Special agreements about other classifications can be made between ISIC A/S and the customer.

Measurement method/monitoring conditions for pixel defects

In compliance with the ISO-9241-307:2008 standard, the following conditions are observed:

- Final check for pixel fault undertaken right after burn-in, i.e. with pre-heating of the display.
- Surrounding temperature $25^{\circ}\text{C} \pm 5^{\circ}\text{C}$
- Relative air humidity 40–70%

Pixel definition

Every pixel consists of three sub-pixels/dots (red, blue, green).

Every sub-pixel has its own transistor.

The three sub-pixels/dots must be considered as one unit.



Pixel

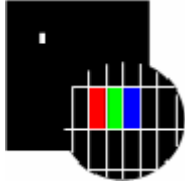

Pixel defect type 1 Pixel constantly lit

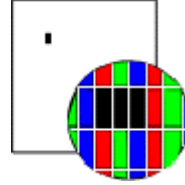

Pixel defect type 2 Pixel constantly dark

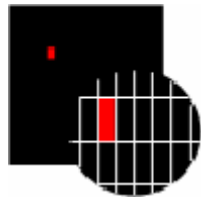

Pixel defect type 3a
Sub-pixel/dot (red, blue, green) constantly lit

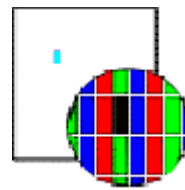

Pixel defect type 3b
Sub-pixel/dot (red, blue, green) constantly dark

Cluster

A cluster consists of 5 x 5 pixels.

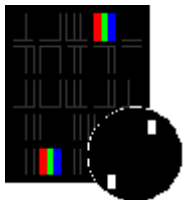

Cluster pixel defect type 1
Pixels in a cluster area constantly lit

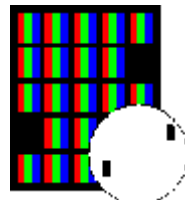

Cluster pixel defect type 2
Pixels in a cluster area constantly dark



Cluster pixel defect type 3a
Sub-pixels/dots in a cluster area constantly lit



Cluster pixel defect type 3b
Sub-pixels/dots in a cluster area constantly dark



Pixel faults accepted by ISIC A/S

The maximum number of pixel faults that is considered acceptable at different screen resolutions is shown in the table below.

This is the native resolution and not the resolution as adjusted by user.

Class II

Allowable number of pixel faults in monitor applications							
Screen type	Native resolution	Number of pixels	Pixel defect type 1	Pixel defect type 2	Pixel defect Type 3 total ($2 \times N_{3a} + N_{3b}$)	Cluster defect type 1 and 2	Cluster defect type 3
XGA	1024x768	768,432	1	1	7	0	0
SXGA	1280x1024	1,310,720	2	2	13	0	1
UXGA	1600x1200	1,920,000	3	3	19	0	1
FHD	1920x1080	2,073,600	4	4	20	0	2
WUXGA	1920x1200	2,304,000	4	4	23	0	2





SCIGATE AUTOMATION (S) PTE LTD

No.1 Bukit Batok Street 22 #01-01 Singapore 659592

Tel: (65) 6561 0488

Fax: (65) 6562 0588

Email: sales@scigate.com.sg

Web: www.scigate.com.sg

Business Hours: Monday - Friday 8.30am - 6.15pm



Edwin Rahrs Vej 54

DK-8220 Brabrand

Denmark

Web: <http://www.isic-systems.com>

Email: service@isic-systems.com

