



## TYPE: SHK-B



# SHK-B Bow Type Cabled Load Shackle

## Description

The LCM range of SHK-B load shackles are designed for lifting and weighing in rugged or harsh environments, including submersible applications. The shackle pins manufactured to an exacting specification and are machined from high tensile stainless steel to 6.5te and forged from high tensile carbon steel from 9.5te. The basic shackle uses the Crosby G2130 (1 to 25te), G2140 (40 to 120te) and GN Rope H10 (150 to 1000te).

This range of load cells is proof loaded to 150% of the normal rated load, and is available in a range from 1 tonne to 1000 tonne. The integral cable is normally protected by the anti-rotation bracket or by a separate protective plate. The SHK-B is internally gauged and the whole instrumented area is sealed to IP67 to protect it in service.

They are simple to install and are available in standard shackle sizes. As an option, a rotating bobbin can be supplied to centralise the load and to minimise any point-load effects when the shackle is placed under load. We are also always happy to discuss any special requirements that can be accommodated.

The SHK-B series can be supplied on its own or combined with our extensive range of instrumentation to provide a complete load monitoring package. A wireless version is also available (see TELSHACK-B data sheet for details).

## Specification

Rated load (tonnes)	1, 2, 3.25, 4.75, 6.5, 9.5, 12, 17, 25, 40, 55, 85, 120, 150, 200, 250, 300, 400, 500, 600, 700, 800, 900, 1000	
Proof load	150% of rated load	
Ultimate breaking load	300% of rated load	
Output	Between 1.8mV and 3.6mV	
Non-linearity	<±1% of rated load (typically)	
Non-repeatability	<±0.1% of rated load	
Excitation voltage	10vdc recommended, 15vdc maximum	
Bridge resistance	350Ω	
Insulation resistance	>500MΩ @ 500vdc	
Operating temperature range	-20 to +70°C (-20 to +55°C for Ex d)	
Compensated temperature range	-10 to +50°C	
Zero temperature coefficient	<±0.01% of rated load/°C	
Span temperature coefficient	<±0.01% of rated load/°C	
ATEX certification details	Ex i	II 2G Ex ib IIC T4 Gb / II 2D Ex ib IIIC T135°C Db
	Ex d	II 2G Ex d IIC T6 Gb / II 2D Ex tb IIIC T85°C Db
Environmental protection level	IP67	
Connection type	10 metre 4 core screened PUR cable (glanded exit)	
Wiring connections	+ve supply: Red	-ve supply: Blue
	+ve signal: Green	-ve signal: Yellow

## Available Options

- Special ranges and capacities up to 2000te
- Hazardous Area certified - Explosion Proof (Ex d) and Intrinsically Safe (Ex i)
- Special electrical connections and integral signal conditioning
- Centralising load bobbin
- Subsea, offshore and ROV friendly versions
- Lloyds, ABS, DNV or other third party witnessing
- 3.2 Material Certification



## Features

- Ranges from 1 tonne to 1000 tonne
- Environmentally sealed to IP67
- Simple installation and operation
- Shackle and load pin fully certified
- Optional load centralising bobbin
- Can be supplied with amplified output
- Submersible and many other options available
- Hazardous Area certified from 3.25 tonnes

## Typical Applications

- Under-hook hoist/crane weighing
- Cable tension monitoring
- Towing/mooring Tension
- Crane safe load monitoring
- Bollard testing





# SHK-B Bow Type Cabled Load Shackle

## Special Options

<b>Special ranges</b>	The SHK-B can be supplied in any range, between 1te and 1000te and calibrated as required. Usually we will choose the nearest standard shackle size. We can also offer special design shackles up to 2000te. Please contact our design team for more details
<b>Special electrical</b>	The standard SHK-B cable exits the shackle pin via a gland and is restrained using the anti-rotation bracket. We can offer variations to the electrical connection method. For example, integral connectors, special cable length etc. For more details contact our office.
<b>Integral signal conditioning</b>	We can offer various integral signal conditioning options: <b>Analogue Signals</b> 4-20mA 2-wire current output (7.5 to 28vdc supply) <b>For ATEX versions see note 4 &amp; 5</b> 4-20mA 3-wire current output (13 to 28vdc supply) <b>For ATEX versions see note 4</b> 0.1-5.1vdc 3-wire voltage output (8.5 to 28vdc supply) <b>For ATEX versions see note 4</b> 0.1-10.1vdc 3-wire voltage output (13 to 28vdc supply) <b>For ATEX versions see note 4</b> <b>Digital Signals</b> RS232 digital - various protocols (5.4 to 18vdc supply) <b>For ATEX versions see note 4</b> RS485 digital - various protocols (5.4 to 18vdc supply) <b>For ATEX versions see note 4</b>
<b>Centralising bobbin</b>	We can offer an optional centralising bobbin. This helps improve the overall accuracy in certain cable tension applications. The bobbin is shown pictorially in the dimensions drawing.
<b>Telemetry</b>	We have a version available that requires no cable connection, using radio telemetry to transmit data. There is a separate data sheet available for this product (TELSHACK-B and TELSACK-B-HL).
<b>Subsea or offshore</b>	We are able to offer fully submersible versions, which are normally supplied with underwater mateable connectors, making them suitable for use in environmental pressures up to 10,000psi. These versions can also be pressure tested by LCM and witnessed by a third party at any point through the manufacturing process. We regularly have ABS, Lloyds or DNV inspectors on site. See below for examples of our submersible load shackles.
<b>Hazardous Area</b>	We can supply ATEX/IECEX certified load shackles for use in Zone 1 and Zone 2 hazardous areas at load ratings to 2000 tonnes.

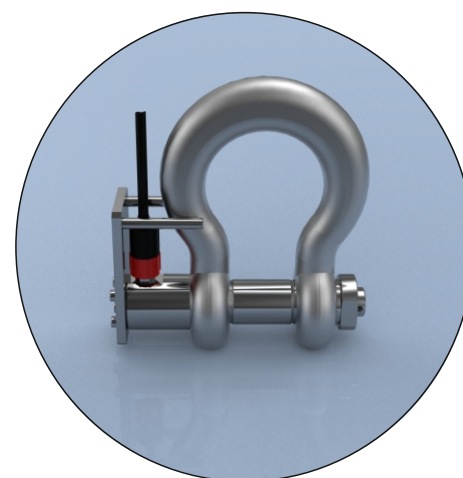
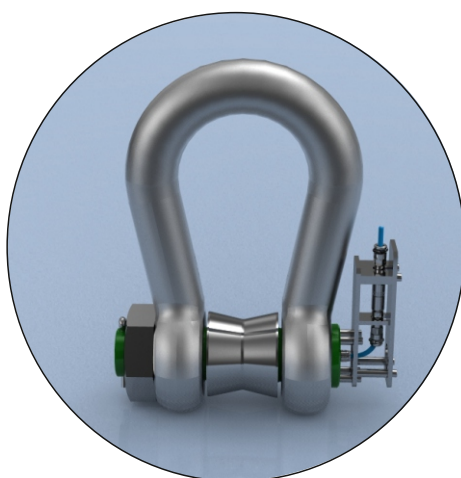
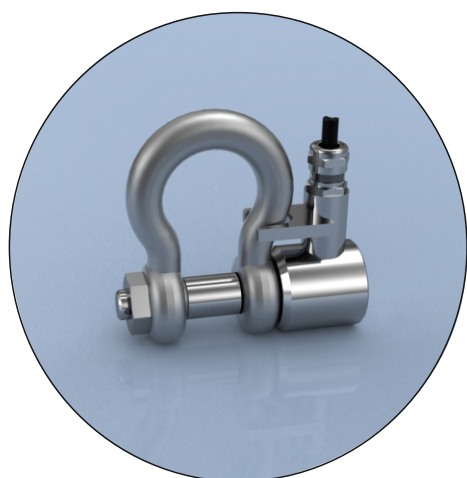

# SHK-B Bow Type Cabled Load Shackle

## Dimensions

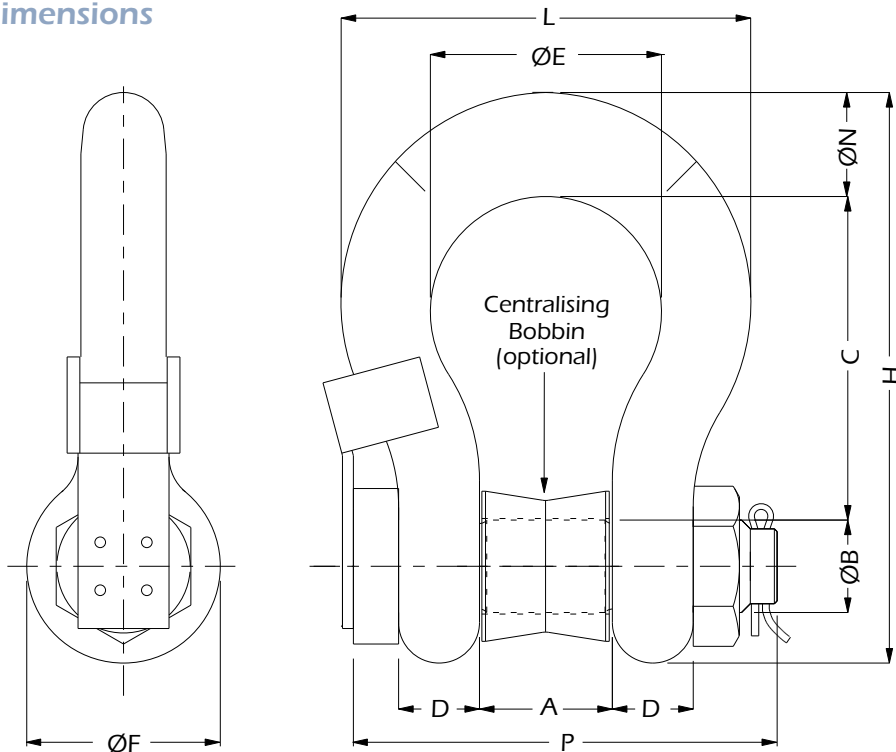

All dimensions are in mm

Rating (tonnes)	A	$\varnothing B$	C	D	$\varnothing E$	$\varnothing F$	H	L	$\varnothing N$	P	Weight (kgs)	Resolution (tonnes)
1	16.8	11.2	36.6	9.65	26.2	23.1	63	45.2	9.65	90	2	0.001
2	20.6	16	47.8	12.7	33.3	30.2	83.5	58.5	12.7	97	2.3	0.002
3.25	26.9	19.1	60.5	16	42.9	38.1	106	74.5	17.5	96	2.8	0.005
4.75	31.8	22.4	71.5	19.1	51	46	126	89	20.6	111	3	0.005
6.5	36.6	25.4	84	22.4	58	53	148	102	24.6	122	3.2	0.005
9.5	46	31.8	108	28.7	74	68.5	190	131	31.8	156	5.2	0.01
12	51.5	35.1	119	31.8	82.5	76	210	146	35.1	171	8	0.01
17	60.5	41.4	146	38.1	98.5	92	254	175	41.1	201	12	0.02
25	73	51	178	44.5	127	106	313	225	57	236	18	0.02
40	73.2	50.8	178	44.5	127	106	313	224	57.2	236	18	0.05
55	82.6	57.2	197	50.8	146	122	347	258	61	269	25	0.05
85	105	69.9	267	66.5	184	148	455	324	79.2	351	45	0.1
120	127	82.6	330	76.2	200	165	546	371	92.2	387	85	0.1
150	170	108	400	102	275	230	671	479	102	475	160	0.1
200	180	125	500	120	290	260	813	530	120	520	235	0.2
250	205	140	540	125	305	260	865	555	125	560	285	0.2
300	205	150	600	130	305	305	958	565	130	570	340	0.5
400	230	175	680	165	325	350	1108	655	165	655	560	0.5
500	255	185	700	180	350	370	1158	710	180	720	685	0.5
600	285	205	700	195	375	405	1200	765	195	815	880	0.5
700	310	217	700	205	400	435	1231	810	205	860	980	1
800	310	217	700	210	400	435	1236	820	210	870	1100	1
900	330	230	700	220	420	465	1268	860	220	910	1280	1
1000	350	240	750	230	420	480	1290	880	230	950	1460	1

Note 1: Our ATEX range starts at 3.25 tonnes.

Note 2: Part numbers for ATEX versions will be suffixed with either -ATEX-D (explosion proof) or -ATEX-I (intrinsically safe) e.g. SHK-B-55-ATEX-D.

Note 3: Dimensions may change for hazardous area versions.

Note 4: Maximum supply voltage for Ex d versions is 27Vdc.

Note 5: Supply voltage for Ex I versions is 9-28vdc (only 2-wire 4-20mA is available with Ex I versions)



**SCIENCE GATE**  
Your Automation Partner

**SCIGATE AUTOMATION (S) PTE LTD**

No 1 Bukit Batok Street 22 #01-01 Singapore 659592  
Tel: (65) 6561 0488 Fax: (65) 6561 0588  
Email: sales@scigate.com.sg Web: https://scigate.com.sg/  
Business Hours: Monday - Friday 8:30AM - 6:15PM

www.lcmssystems.com

**LCM Systems Ltd**

Unit 15, Newport Business Park, Barry Way  
Newport, Isle of Wight PO30 5GY UK  
Tel: +44 (0)1983 249264  
sales@lcmssystems.com  
www.lcmssystems.com

**LCM Systems (România)**

Strada Ștefan Cel Mare 26a,  
Tunari, cod.077180, Ilfov, România  
Tel: +40 (0)77 4641899  
ro@lcmssystems.com  
www.lcmssystems.ro

Due to continual product development, LCM Systems Ltd reserves the right to alter product specifications without prior notice.

**Issue No. 5**

Issue date: 25/02/2021  
APPROVED  
(unapproved if printed)