



USB Strain Module



Introduction

The DSCUSB is a compact, high performance strain gauge digital signal conditioner with USB connectivity aimed at applications which require high-accuracy measurement and repeatability.

A rugged and compact ABS IP50 enclosure makes the device suitable for all environments. Simply by plugging the device into a PC, data can be extracted from most strain gauge bridge input sensors and acquired by software which allows data manipulation removing the need for amplifiers, filters & multimeters. No additional power supply is required.

The Toolkit is designed for connection to a single DSCUSB, however with the use of a suitable USB hub LOG24 can connect to multiple DSCUSB modules. Available in ASCII protocol, offering higher resolution and lower temperature drift.

Simply by plugging the device into a PC, data can be extracted from a sensor to the DSCUSB for a wide range of systems. This is achieved using the Toolkit software, which has been developed in-house by our design engineers to provide configuration, calibration, data review and recording.

This free-standing module is fitted with 9-way 'D' type socket for connection to the strain bridge or load cell while a micro USB socket allows connection to a PC and does not require external power. A DIN rail mounting option is also available.

Product Features & Benefits

- **Quick Setup:**
Simple USB 'Plug and Measure' device connects to a PC directly, allowing quick setup
- **High Stability & Superior Performance:**
200 samples per second at 18 bits noise free resolution providing accurate measurement. Ideal for Test & Measurement, R&D and laboratory environments
- **Connect to Multiple Devices:**
Ability to communicate to multiple sensors
- **Free Toolkit Software:**
Easy connection to Toolkit software for simple configuration
- **Multipoint Linearisation:**
Allows correction for non-linear sensors

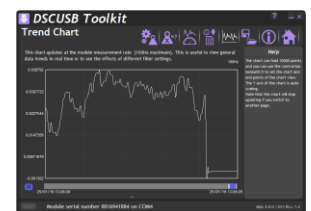
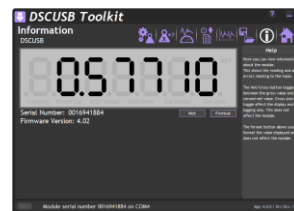

Accessories



DSCUSBOEM
PCB version of the DSCUSB
Available with added mounting holes



DSCUSBOEM1
The new PCB version with connectors and a 9 way D type slot and micro USB

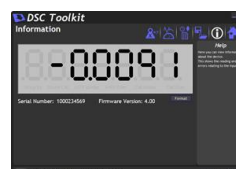
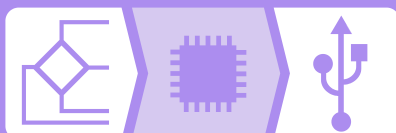

Free DSCUSB Toolkit Software
Calibrate and configures the DSCUSB



Free LOG24 Software
View and log up to 24 channels

Specifications

Parameter	
Strain Gauge Measurement	4 Wire
Strain Gauge Excitation Voltage	5 V dc
Strain Gauge Drive Capability	85 Ohms
Strain Gauge Sensitivity	3 mV/V
Offset Temperature Stability	4 ppm / °C
Gain Temperature Stability	5 ppm / °C
Non Linearity before Linearization	25 ppm of FR
Internal Resolution	16 Million Counts/divs
Resolution @ 1Hz readings (Noise stable) over 100s	200,000 Counts/divs
Resolution @ 10Hz readings (Noise stable) over 100s	120,000 Counts/divs
Resolution @ 100Hz readings (Noise stable) over 100s	50,000 Counts/divs

Electrical

Power Supply Voltage (USB)	5 V dc
Power Supply Current (350 Ohm Bridge)	68 mA

Data Transmission

Maximum Output Cable Length	5 m
Data Transmission Rate	115.200 kbps

Environmental

Operating temperature range	-40 to +85 °C
Storage temperature range	-40 to +85 °C
Maximum Humidity	95% RH
Protection	IP50

Dimensions

Cased Version	70.5 x 51 x 20mm excluding 9-way 'D' type socket connector.
	74.5 x 51 x 20mm including connector.



SCIGATE AUTOMATION (S) PTE LTD

No.1 Bukit Batok Street 22 #01-01 Singapore 659592

Tel: (65) 6561 0488

Fax: (65) 6562 0588

Email: sales@scigate.com.sg

Web: www.scigate.com.sg

Business Hours: Monday - Friday 8.30am - 6.15pm

Mechanical

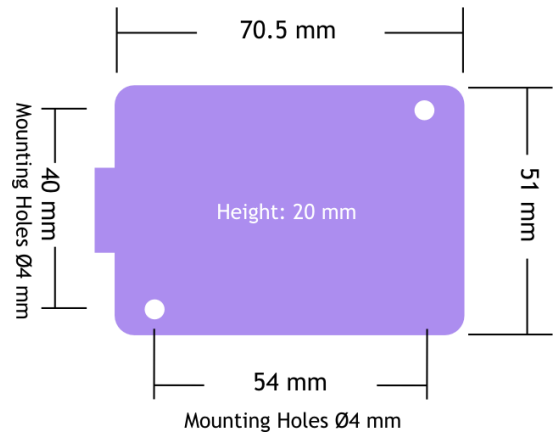

Electrical

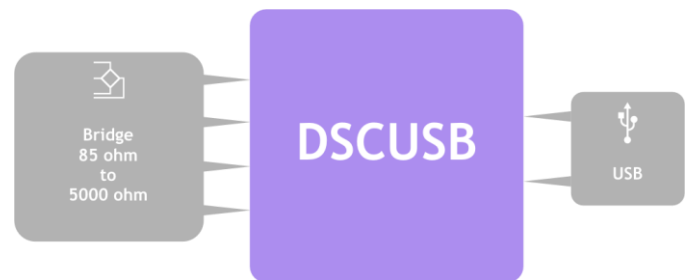

Order Codes

DSCUSB

USB Strain Module

DSCUSBOEM

USB Strain Module OEM

DSCUSBOEM1

USB Strain Module OEM with Connectors

DTEMP

Digital Temperature Sensor Module

D4

Din Rail Mounting Kit

Manual Reference: 517-933 & 517-934

Mantracourt Electronics Ltd

The Drive, Farrington
Exeter, Devon, UK
EX5 2JB

Tel: +44 (0)1395 232020

Email: sales@mantracourt.com

mantracourt.com

