

## EZ Fingerprint Recognition Unit

### ■ Specifications

	
Model	PFXZCCEUSS1
Supported software	GP-Pro EX Ver. 4.07.100 or later
Rated input voltage	24Vdc
Input voltage limits	20 to 30Vdc
Voltage drop	1ms
Power consumption	1.6W max
In-rush current	2.5A max
Voltage endurance	AC 2kV
Insulation resistance	10MΩ or more
Operating temperature	0 to 50°C (32 to 122 F)
Storage temperature	-25 to 70°C (-13 to 158 F)
Surrounding air and storage humidity	0 to 85%
Dust	IP65 front face, IP20 back
Pollution degree	DP2
Corrosive gasses	Free of corrosive gasses
Operating altitude	0 to 2000m (0 to 6,561 ft.)
Vibration resistance	1gn - 9Hz to 500 Hz Amplitude 3mm - 5Hz to 9Hz
Electrical fast transient burst	IEC61000-4-4 2kV power port
Electromagnetic field	IEC61000-4-3 10 V/m
Electrostatic discharge immunity	IEC61000-4-2 4kV contact discharge, 8kV air discharge
Shock resistance	50gn, duration 11ms
No-load current consumption	50mA or less
Delays	First-up: less than 2s, Normal operating: less than 1s
External dimensions	W69.3 x H54 x D78.5 mm (W2.73 x H2.13 x D3.09 in.)
Structure	NEMA #250/UL50 TYPE 12 (on the front panel when properly installed in an enclosure)
Cable length	USB cable: 1.0 m (3.28 ft.) Power cable: 2.0 m (6.56 ft.)
Weight	140g [0.31 lb]
Memory capacity	100 users (2 fingerprints for one user)
Error rate	0.1% or less

### ■ External Dimensions

mm (in.)

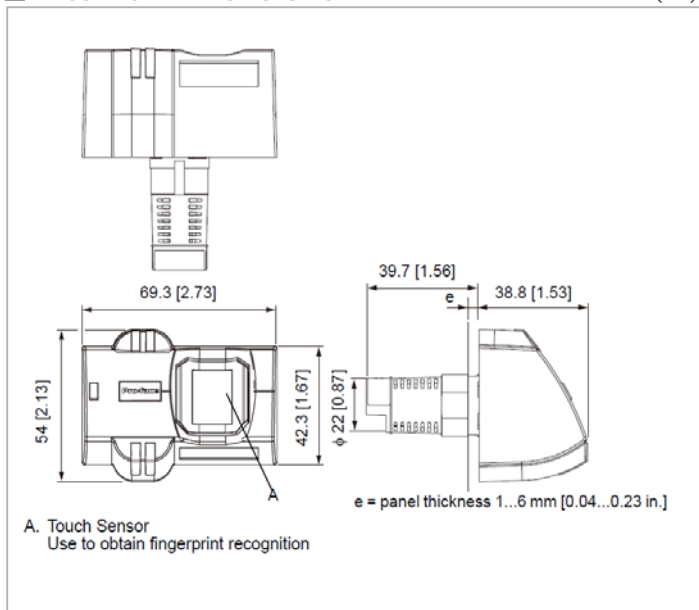

#### Attention: Compliance with laws in operating countries

EZ Fingerprint Recognition Unit involves fingerprint technology. In some jurisdictions, this product may be subject to notification to and/or approval by relevant local regulatory authority prior to importing this product into such jurisdictions and/or using this product in such jurisdictions. The jurisdictions which do not require such notification and/or approval as of July 1, 2013 ("Non-regulated Jurisdictions") are as follows:

Japan, Korea, Taiwan, Thailand, USA, Canada, Mexico, Brazil, Australia, Singapore

In any other jurisdictions, we strongly suggest importers and users to contact the local authority and make inquiries as to notification and/or approval requirements with respect to the imports and the use of this product.

Furthermore, if you intend to incorporate this product into any machine, device or application, additional regulations may apply. We also encourage importers and users in the Non-regulated Jurisdictions to confirm the latest notification and/or approval requirements with the local authority as relevant regulations may change from time to time.

It is your responsibility to comply with laws that regulate this product. We will not be liable for any claims or litigation arising from the imports or the use of this product in any jurisdiction. You will indemnify us from any claims or litigation arising from the imports or the use of this product.

